

[54] **GUITAR BODY**

[56] **References Cited**

[76] **Inventor: Angelo G. Tornese, 8521 Oakford Dr., Springfield, Va. 22152**

**U.S. PATENT DOCUMENTS**

- D. 105,339 7/1937 Mickus ..... D17/18
- D. 181,867 1/1958 McCarty ..... D17/19
- D. 204,331 4/1966 Robins et al. .... D12/333
- D. 224,050 6/1972 Gaudio ..... D17/19
- 3,440,919 4/1969 Baker ..... D17/14

[\*\*] **Term: 14 Years**

*Primary Examiner*—Jane E. Corrigan

[21] **Appl. No.: 404,865**

[57] **CLAIM**

The ornamental design for a guitar body, as shown and described.

[22] **Filed: Aug. 3, 1982**

**DESCRIPTION**

[52] **U.S. Cl. .... D17/18; D17/19; D17/20**

**FIG. 1** is a top plan view of a guitar body showing my new design;

[58] **Field of Search .... D17/14, 15, 18, 19, D17/20; 84/267, 291, 292; D12/333; D21/87**

**FIG. 2** is a bottom plan view thereof; and

**FIG. 3** is a right side elevational view thereof.

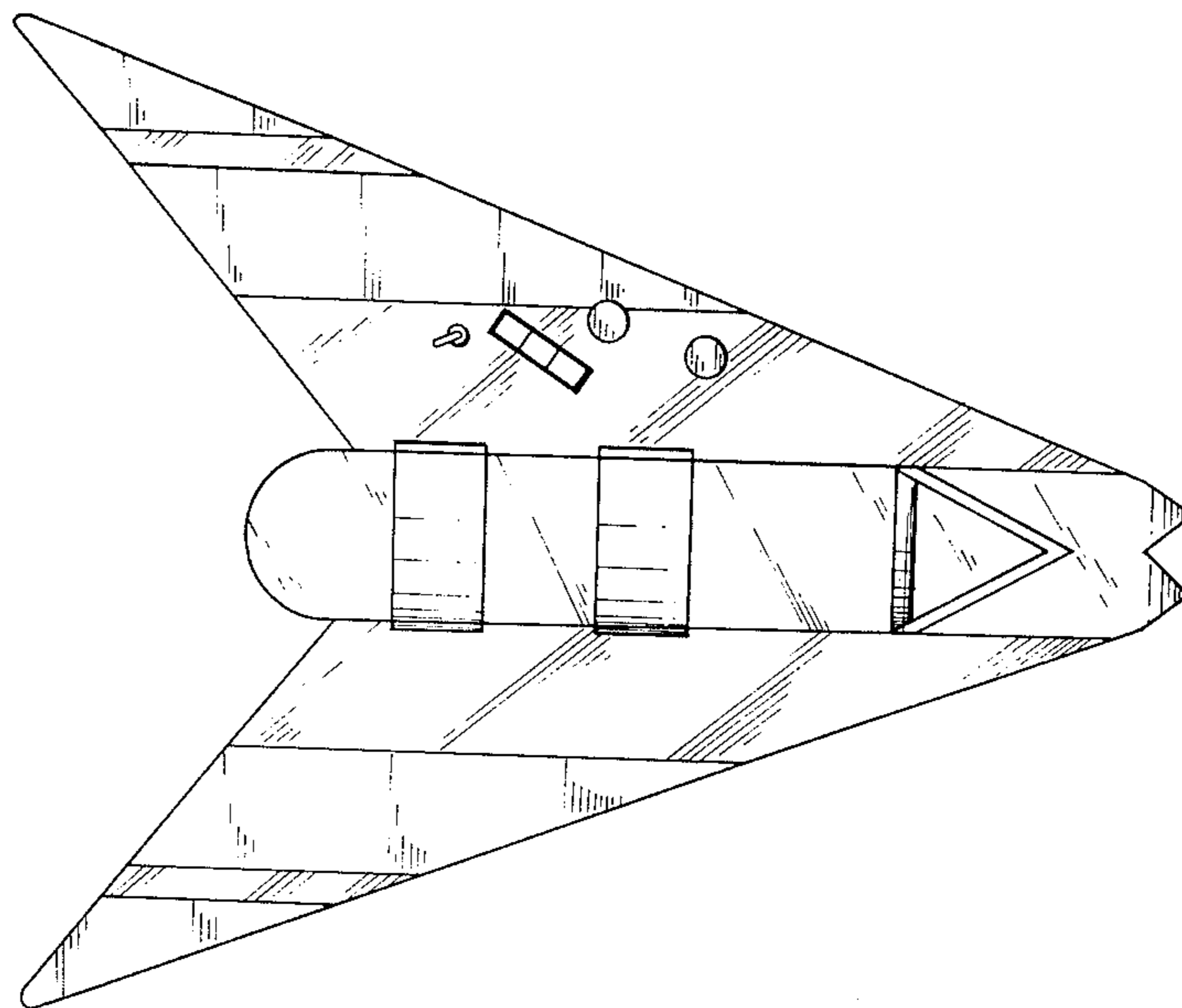

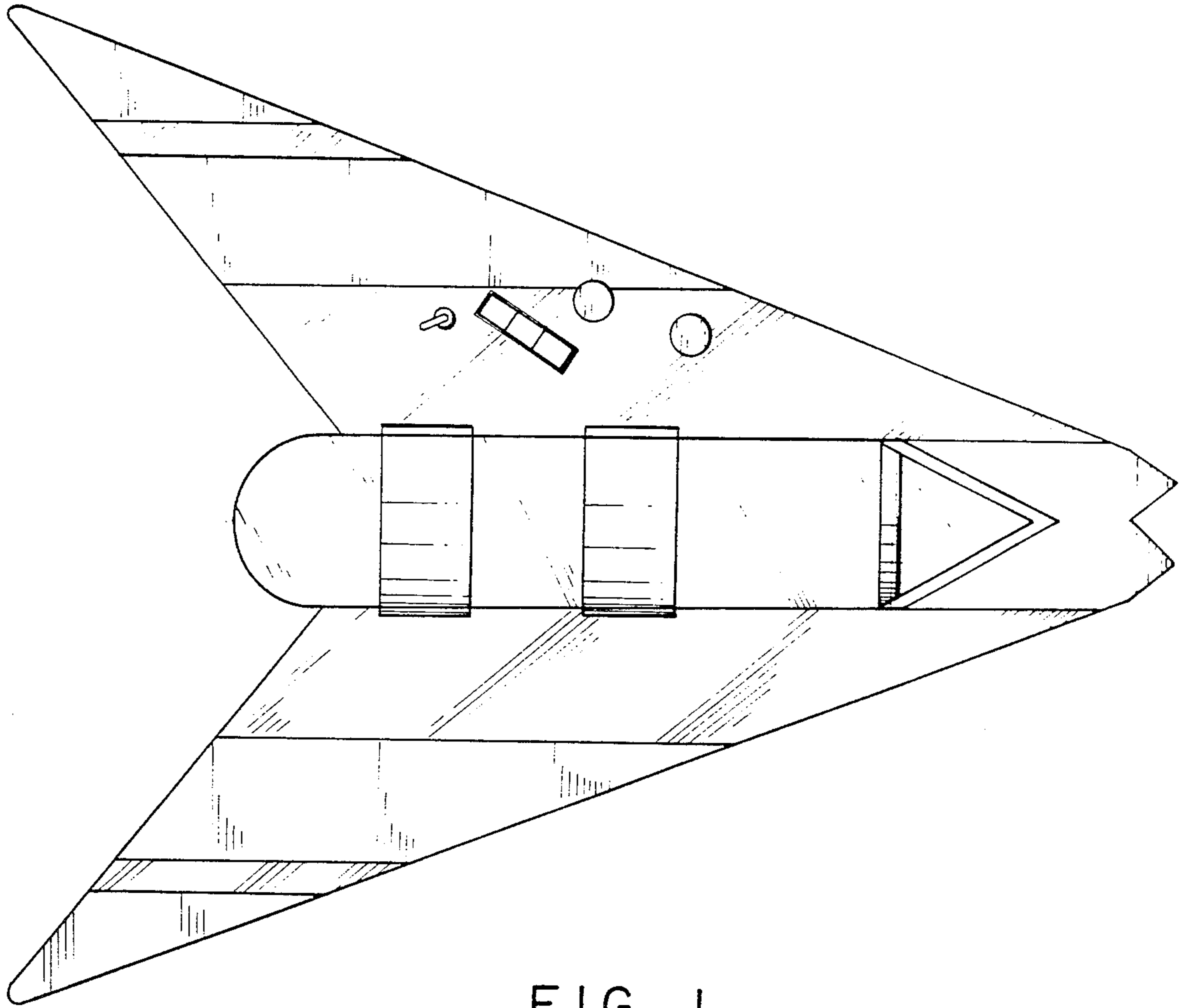

FIG. 1

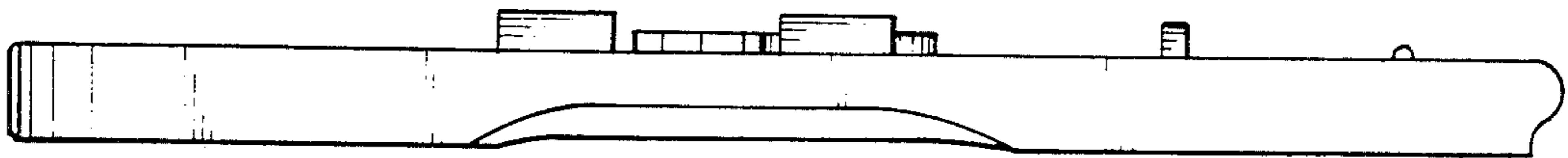

FIG. 3

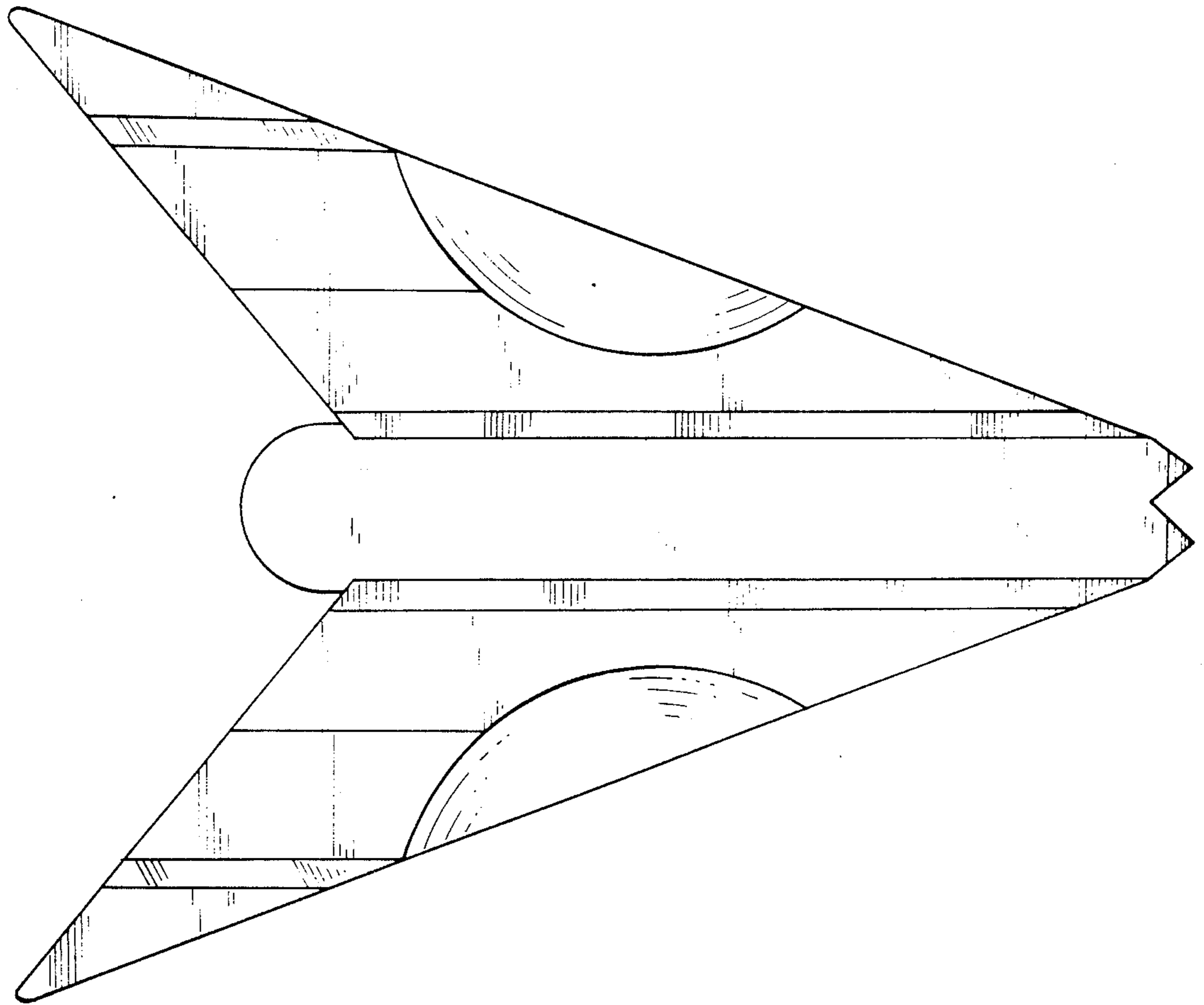

FIG. 2