

[54] VEHICLE WHEEL

[75] Inventor: John A. Main, Plymouth, Mich.

[73] Assignee: Kelsey-Hayes Company, Romulus, Mich.

[**] Term: 14 Years

[21] Appl. No.: 485,139

[22] Filed: Apr. 14, 1983

[52] U.S. Cl. D12/209

[58] Field of Search D12/209, 212; 301/63 R, 301/63 PW, 64 R, 64 SD, 65

[56] References Cited

U.S. PATENT DOCUMENTS

D. 232,632	9/1974	Brown	D12/212
D. 235,539	6/1975	Asberg	D12/211
D. 265,984	8/1982	Main	D12/212

OTHER PUBLICATIONS

1983 Ford Ltd Catalog, p. 15, Wheel Cover (I), center of page.

Road & Track, 6/82, p. 66, Wheel, center of page.

Primary Examiner—James M. Gandy

Attorney, Agent, or Firm—Ralph J. Skinkiss

[57] CLAIM

The ornamental design for a vehicle wheel, as shown.

DESCRIPTION

FIG. 1 is a perspective view of a vehicle wheel showing my new design.

FIG. 2 is a front elevational view thereof.

FIG. 3 is a sectional view taken along line 3—3 in FIG. 2.

FIG. 4 is a sectional view taken along line 4—4 in FIG. 2.

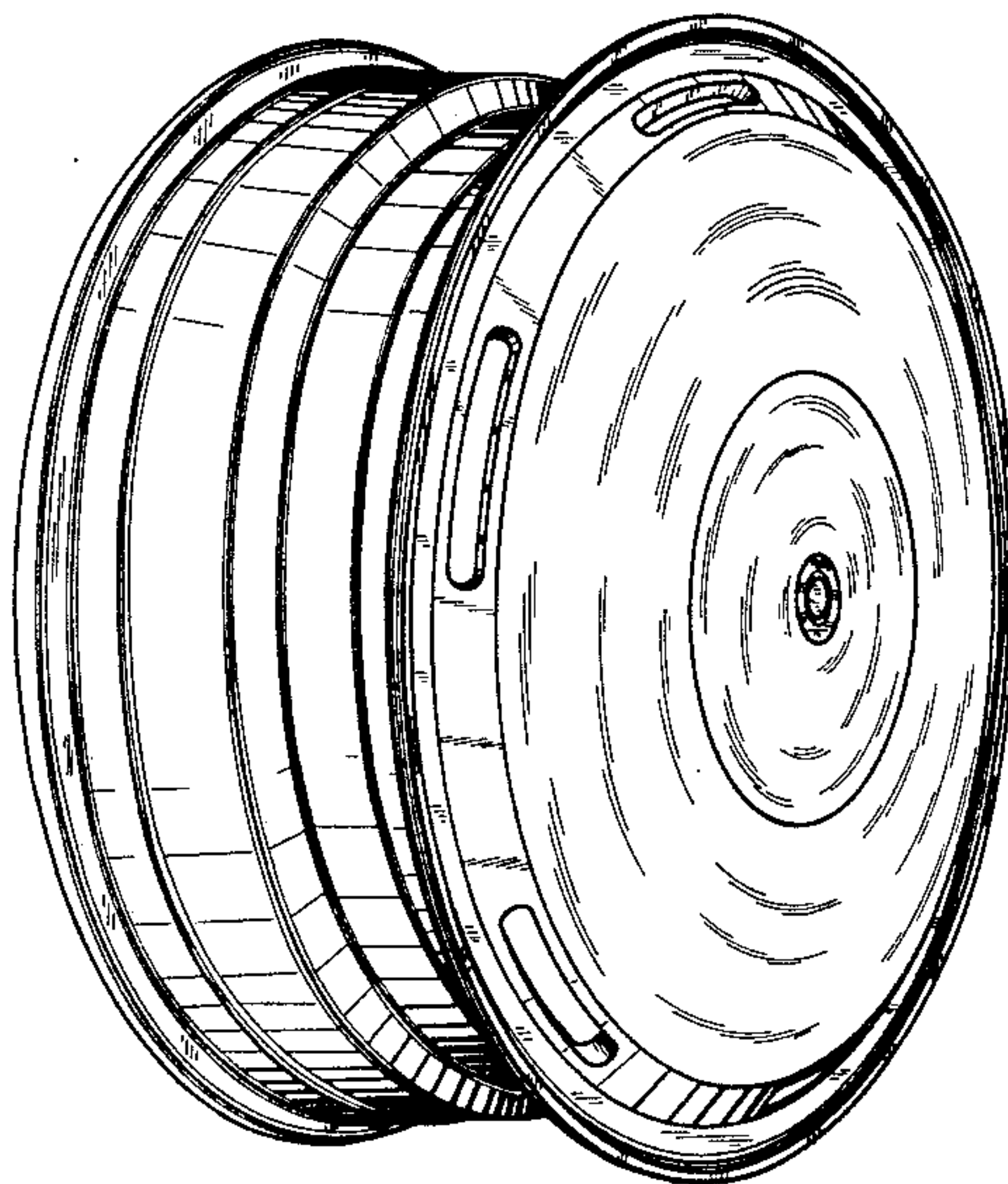

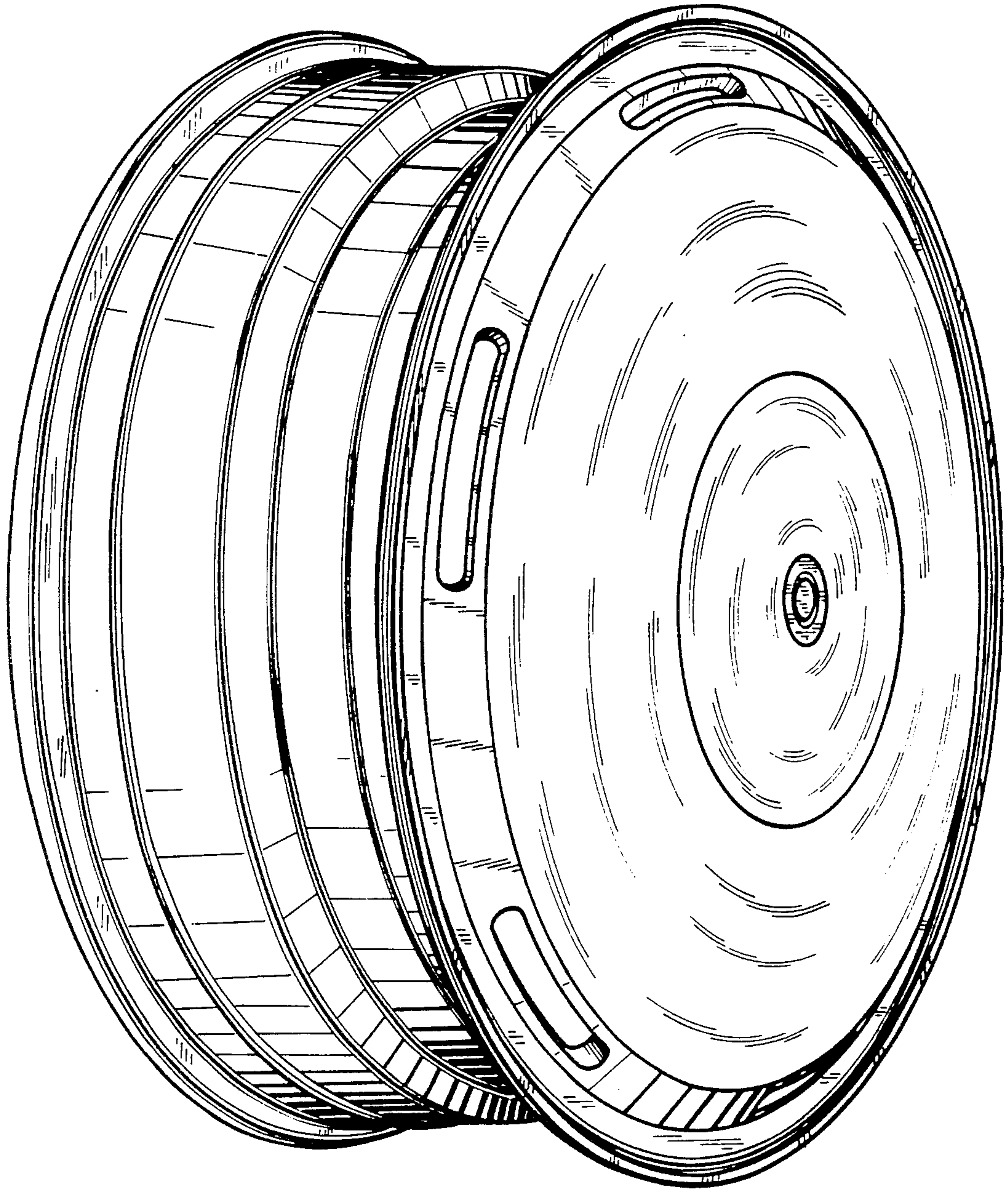

—FIG. 1

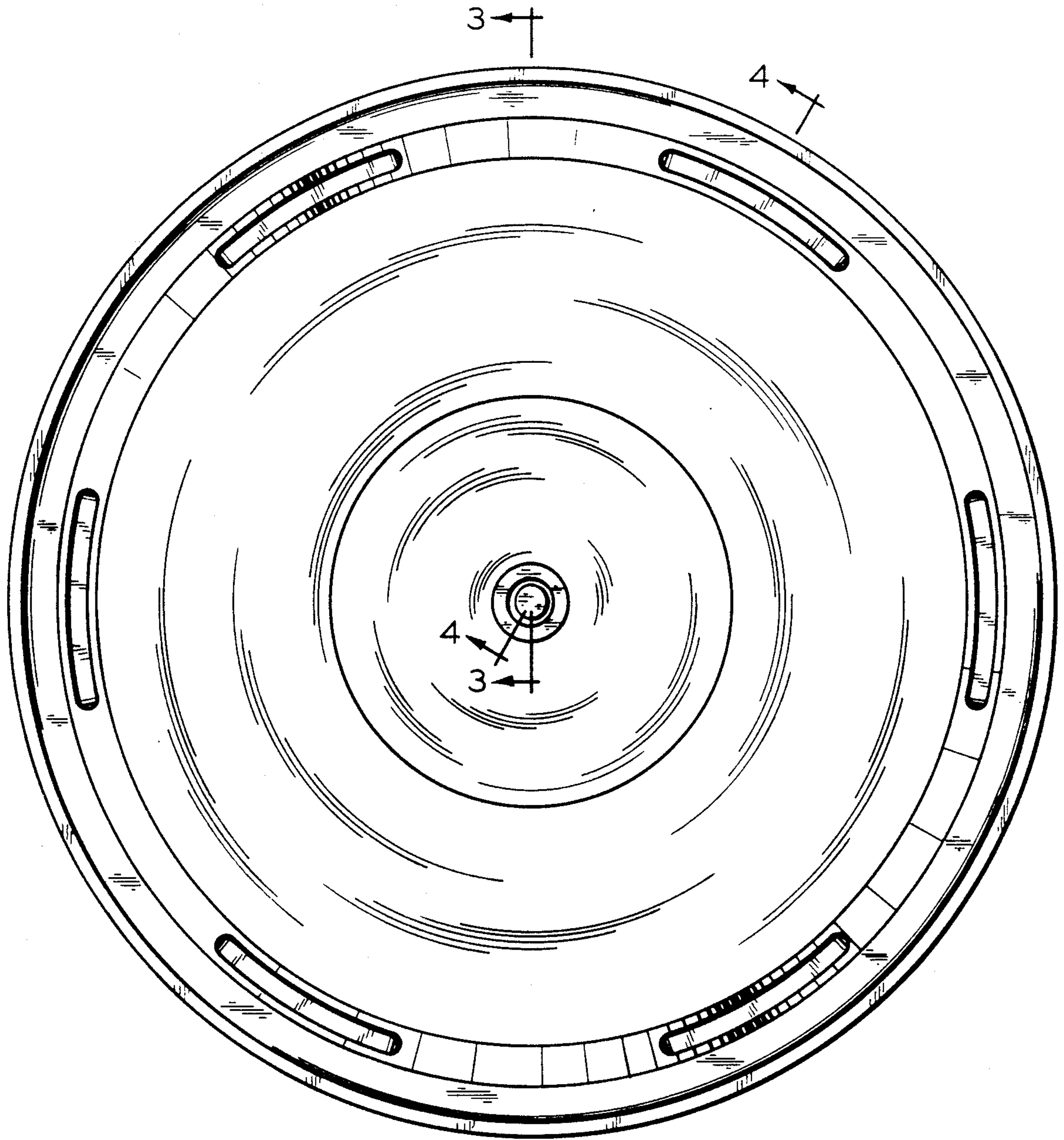

—FIG. 2

— FIG. 3

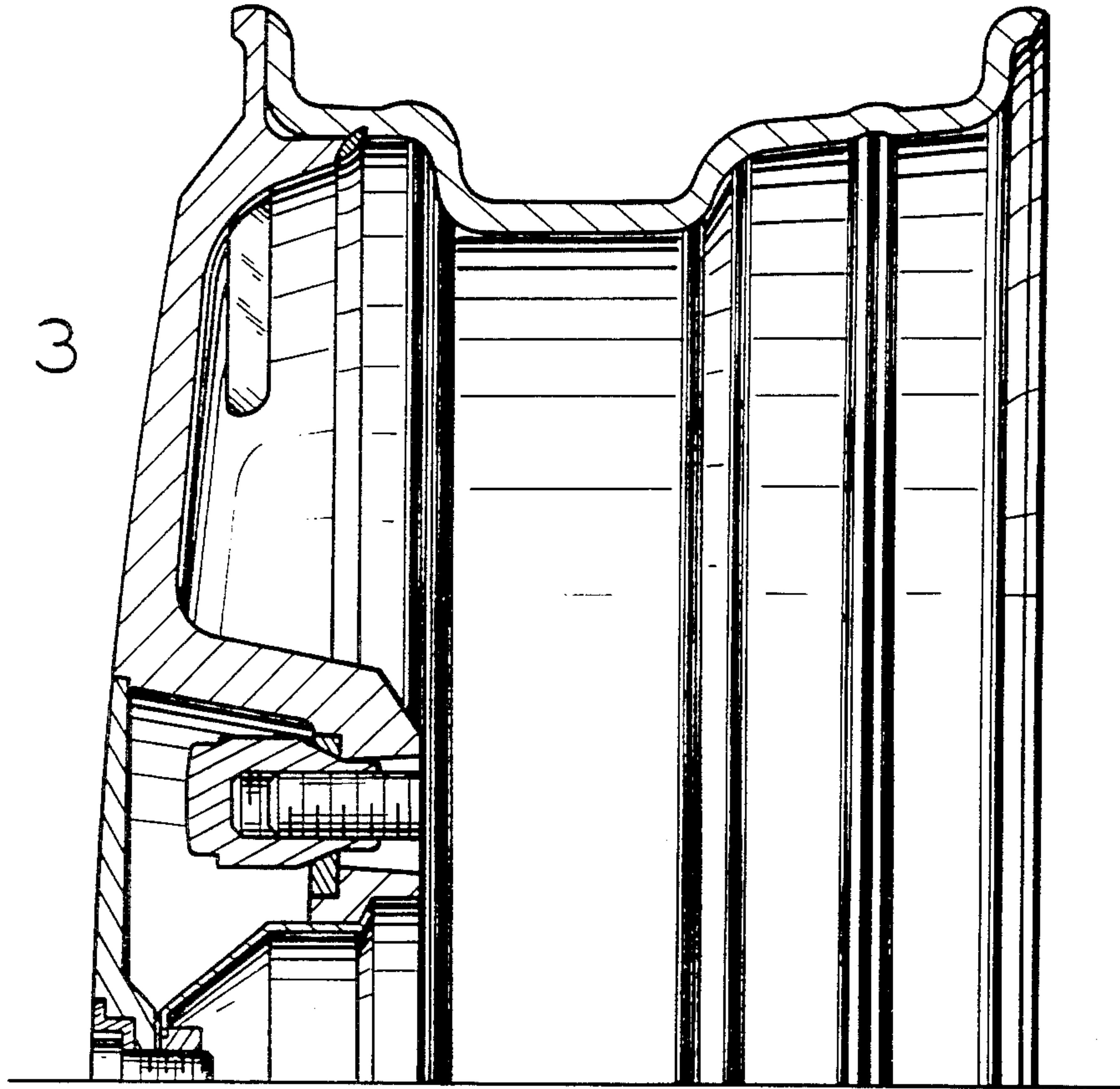

— FIG. 4

