

[54] SINGLE SEAT SPORTS CAR

[75] Inventor: Royston C. Lunn, Ann Arbor, Mich.

[73] Assignee: Renault/Jeep Sport, Inc., Detroit, Mich.

[\*\*] Term: 14 Years

[21] Appl. No.: 543,917

[22] Filed: Oct. 20, 1983

[52] U.S. Cl. .... D12/88; D12/92

[58] Field of Search ..... D12/88, 91, 92; 296/185.1 S

[56] References Cited

U.S. PATENT DOCUMENTS

- D. 221,378 8/1971 Williams ..... D12/92
- D. 225,351 12/1972 Broadley ..... D12/92

OTHER PUBLICATIONS

Road & Track, 6/81, p. 172, 1965 McLaren MK II, bottom right side of page.  
Motor Trend, 3/82, p. 51, Porsche 917-30.

Primary Examiner—James M. Gandy  
Attorney, Agent, or Firm—Brooks & Kushman

[57] CLAIM

The ornamental design for a single seat sports car, as shown.

DESCRIPTION

FIG. 1 is a perspective view of a single seat sports car showing my new design;  
FIG. 2 is a front perspective view thereof;  
FIG. 3 is a side elevation view thereof;  
FIG. 4 is a rear perspective view thereof; and  
FIG. 5 is a top plan view thereof.

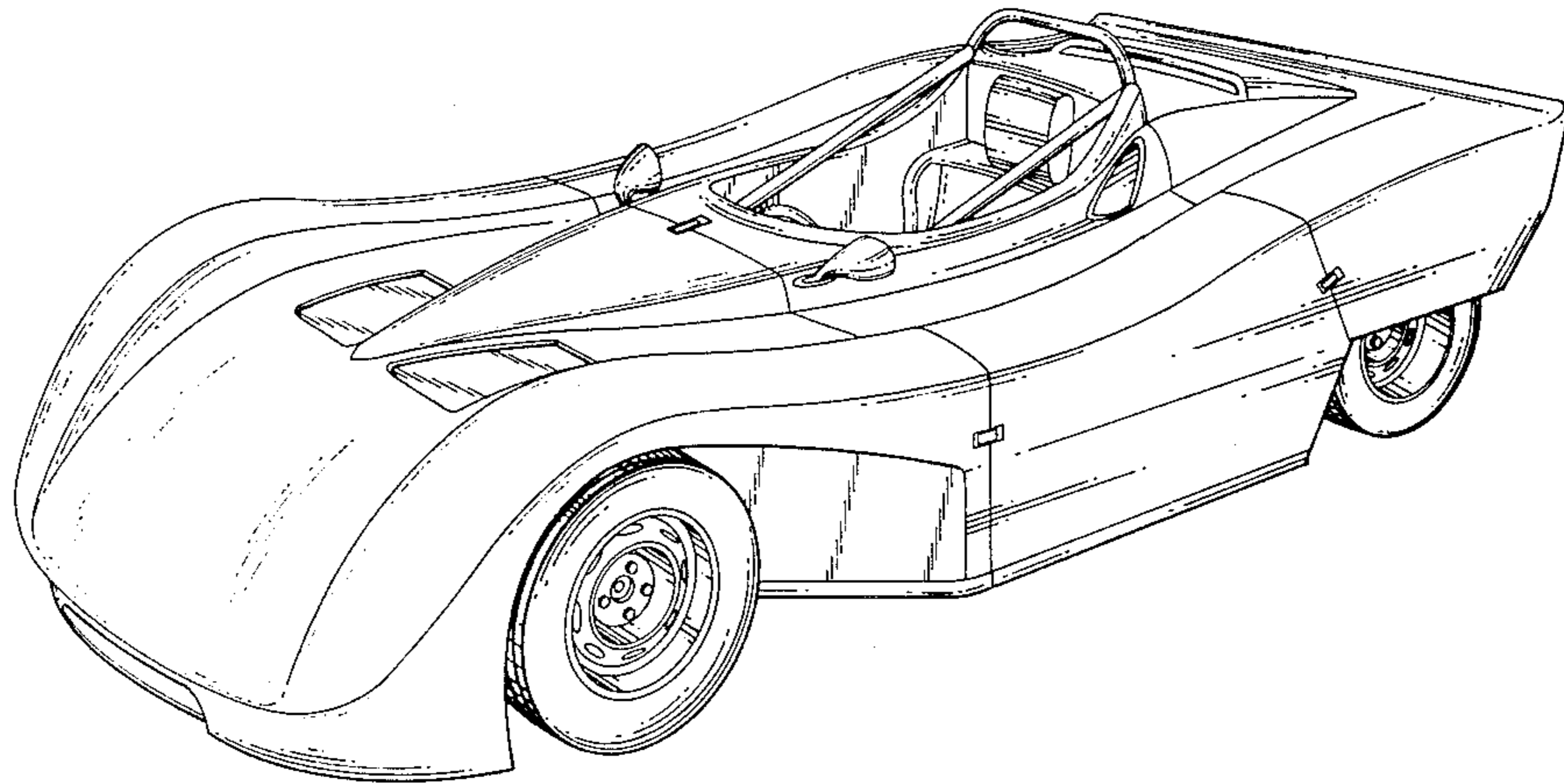

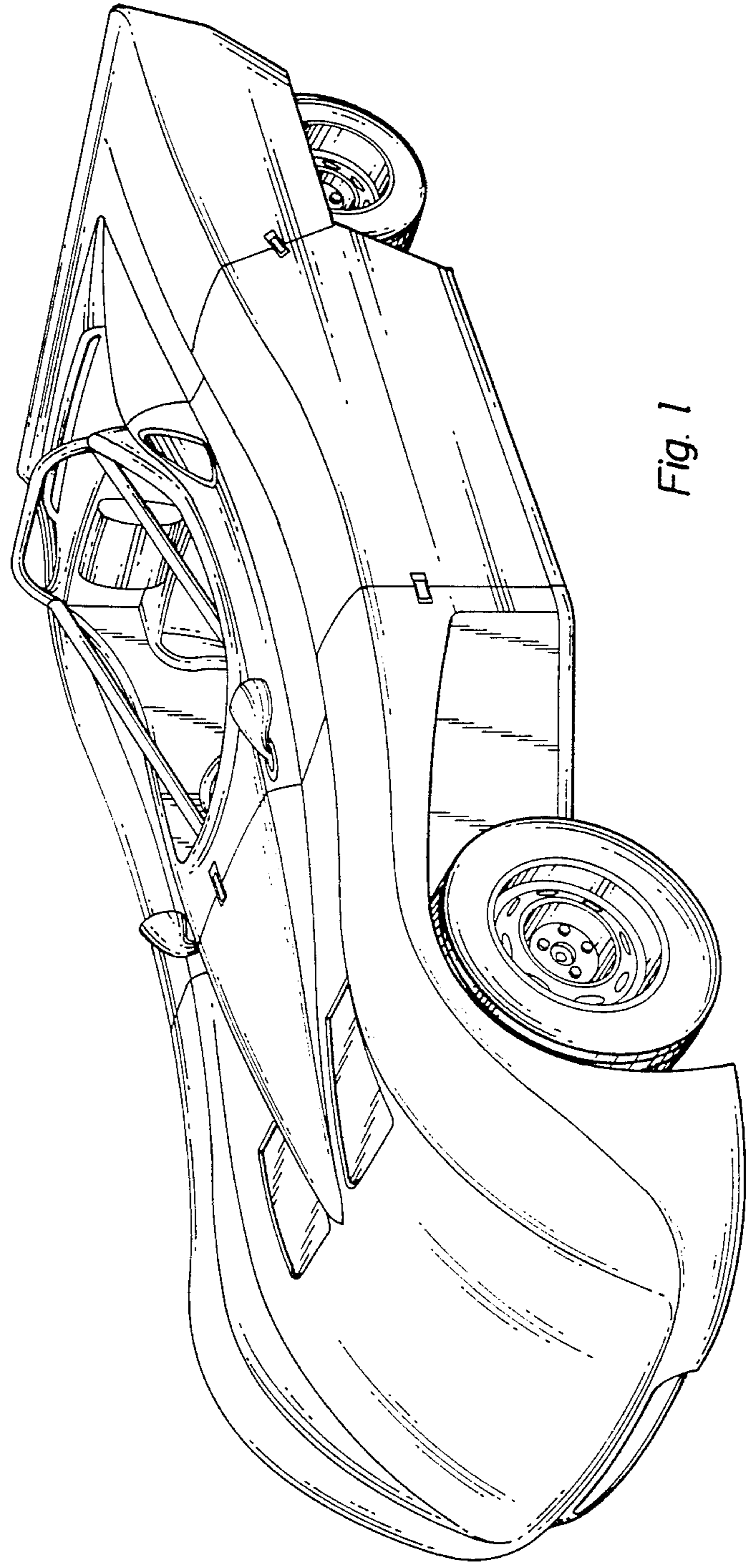
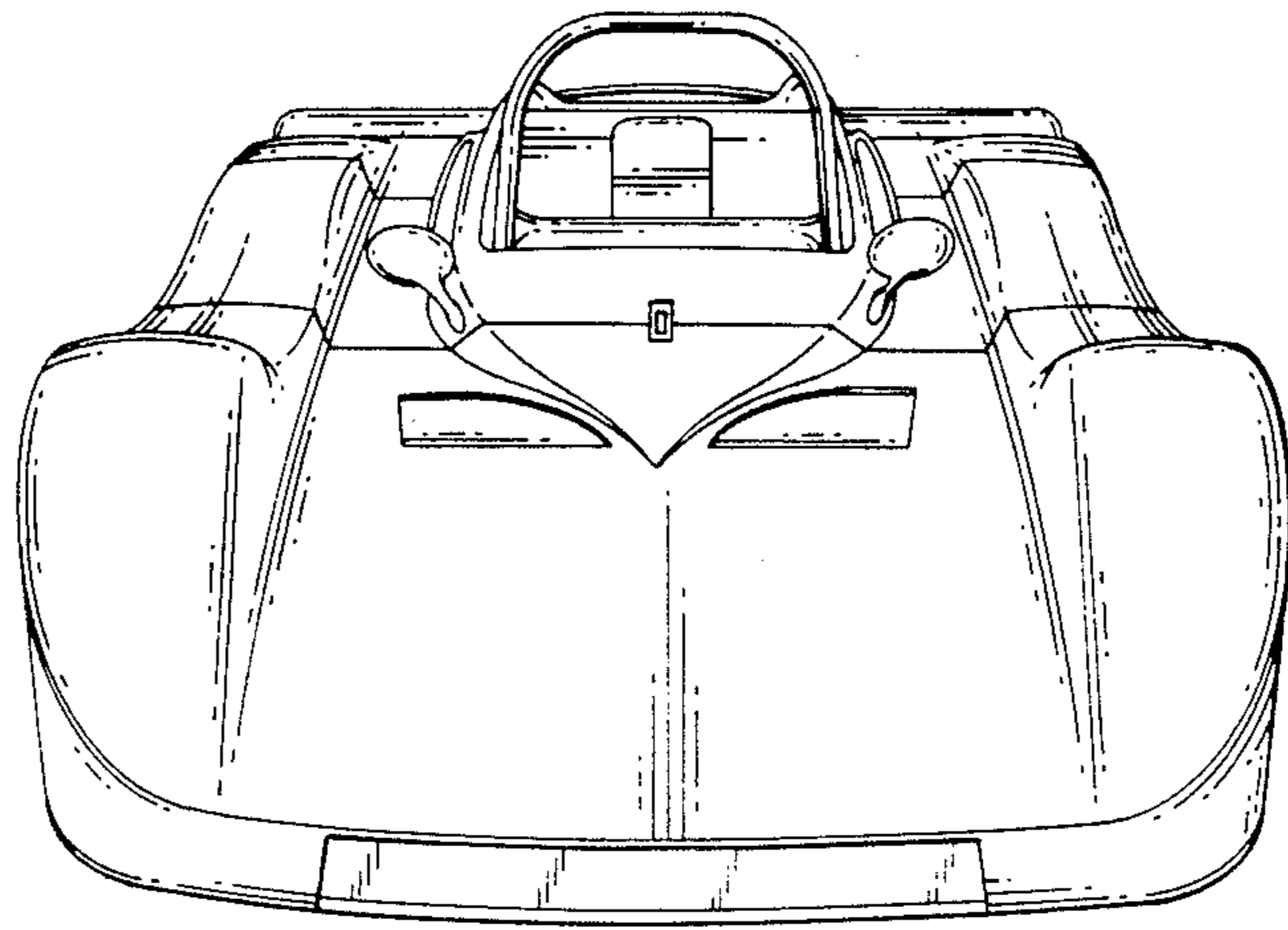
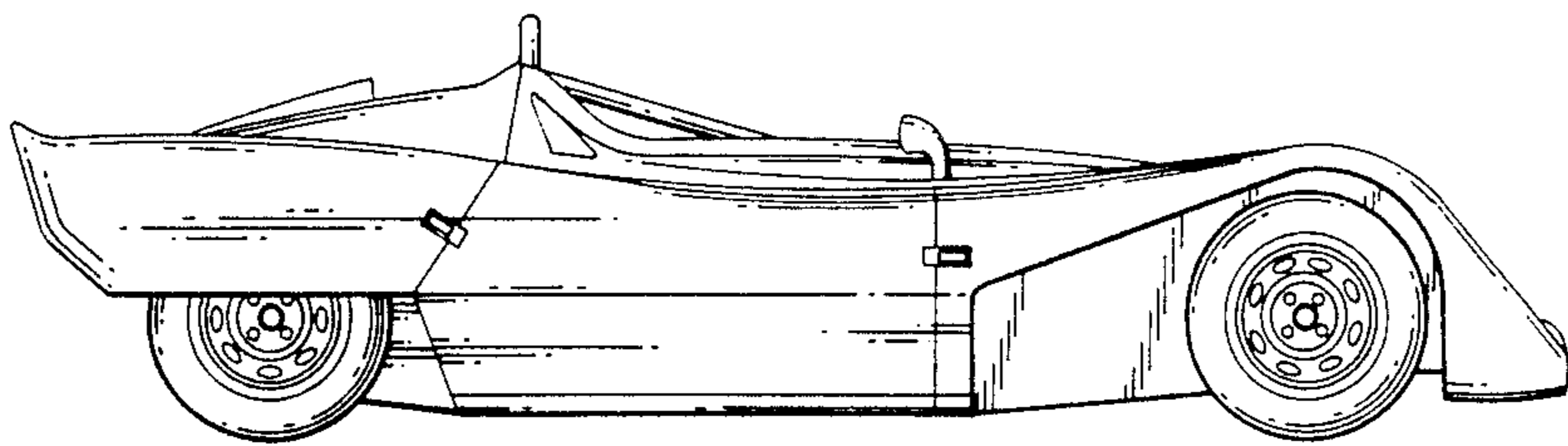

Fig. 1



*Fig. 2*



*Fig. 3*

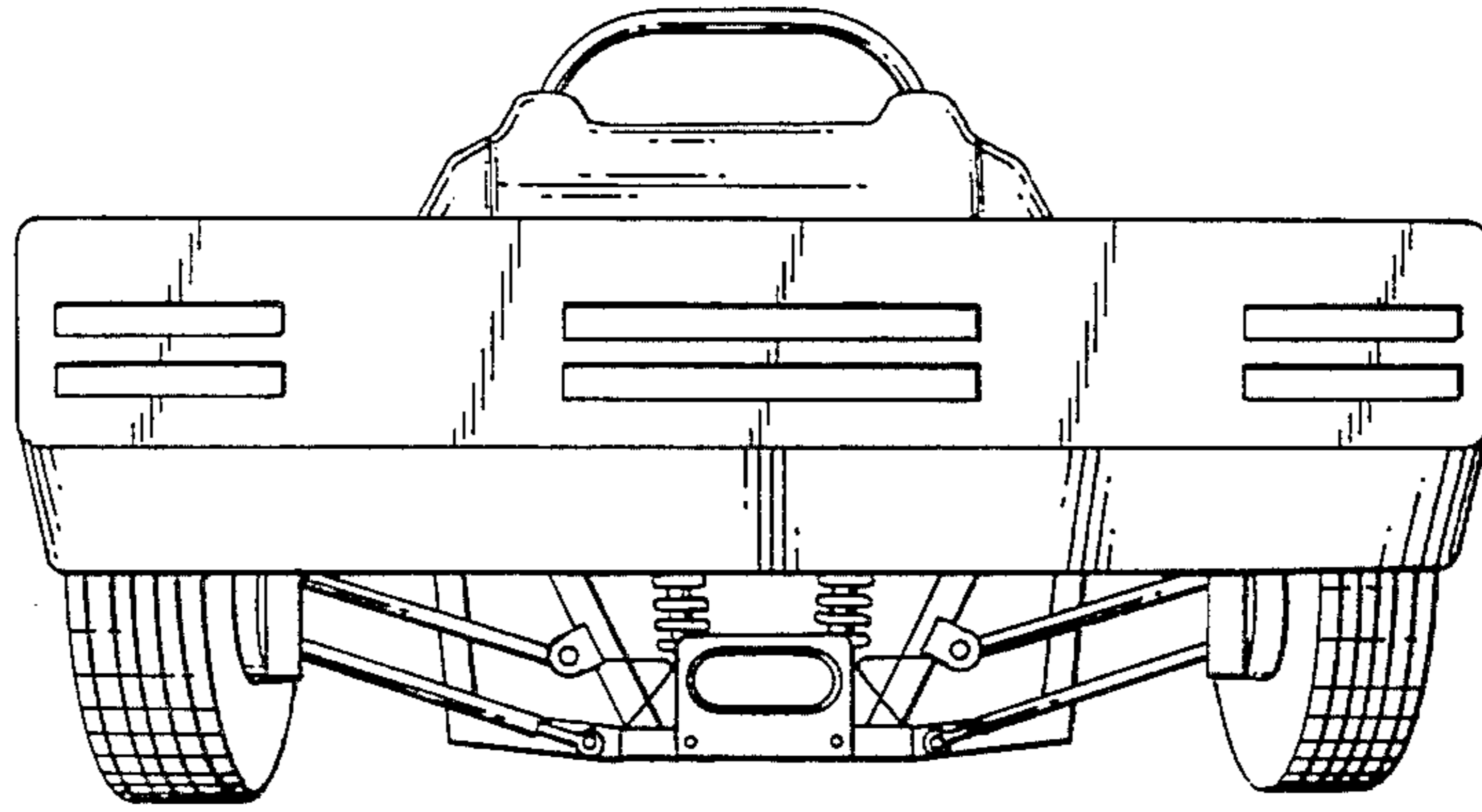

Fig. 4

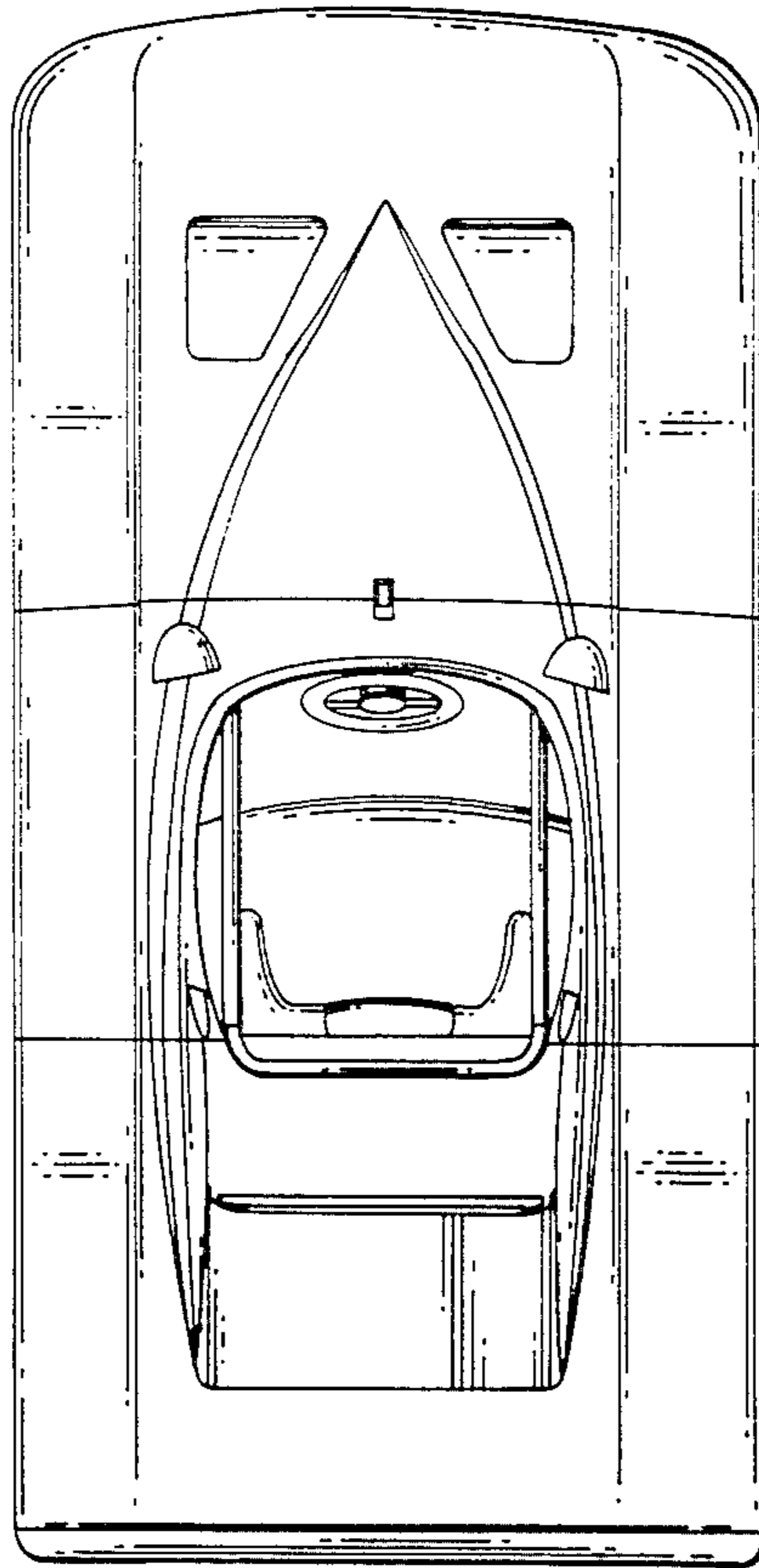

Fig. 5