

[54] **MOTORCYCLE**

[75] **Inventors: Kentaro Ito, Tokyo; Shoichi Kuwahata; Munehito Nakamura, both of Saitama, all of Japan**

[73] **Assignee: Honda Giken Kogyo Kabushiki Kaisha, Tokyo, Japan**

[**] **Term: 14 Years**

[21] **Appl. No.: 464,719**

[22] **Filed: Feb. 7, 1983**

[30] **Foreign Application Priority Data**

Aug. 10, 1982 [JP] Japan 57-36234

[52] **U.S. Cl. D12/110**

[58] **Field of Search D12/110; 180/219, 221, 180/229, 231**

[56] **References Cited**

U.S. PATENT DOCUMENTS

- D. 269,169 5/1983 Ban et al. D12/110
- D. 269,171 5/1983 Ikeda et al. D12/110
- D. 273,853 5/1984 Kawashima et al. D12/110

Primary Examiner—James M. Gandy
Attorney, Agent, or Firm—Lyon & Lyon

[57] **CLAIM**

The ornamental design for a motorcycle, as shown.

DESCRIPTION

FIG. 1 is a front elevation view of a motorcycle showing our new design;
 FIG. 2 is a rear elevation view thereof;
 FIG. 3 is a left side elevation view thereof;
 FIG. 4 is a right side elevation view thereof;
 FIG. 5 is a top plan view thereof;
 FIG. 6 is a bottom plan view thereof; and
 FIG. 7 is a perspective view thereof.

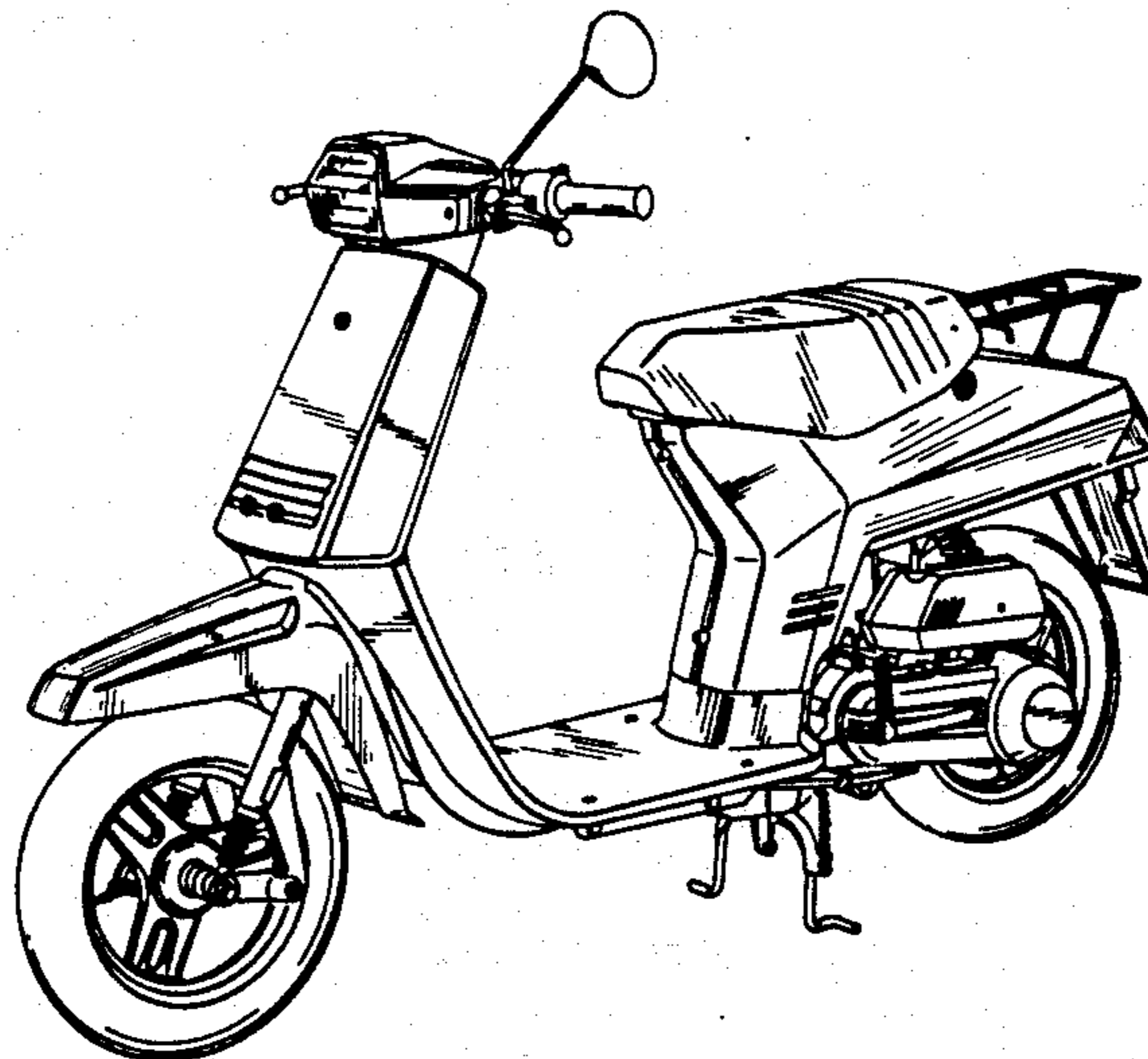

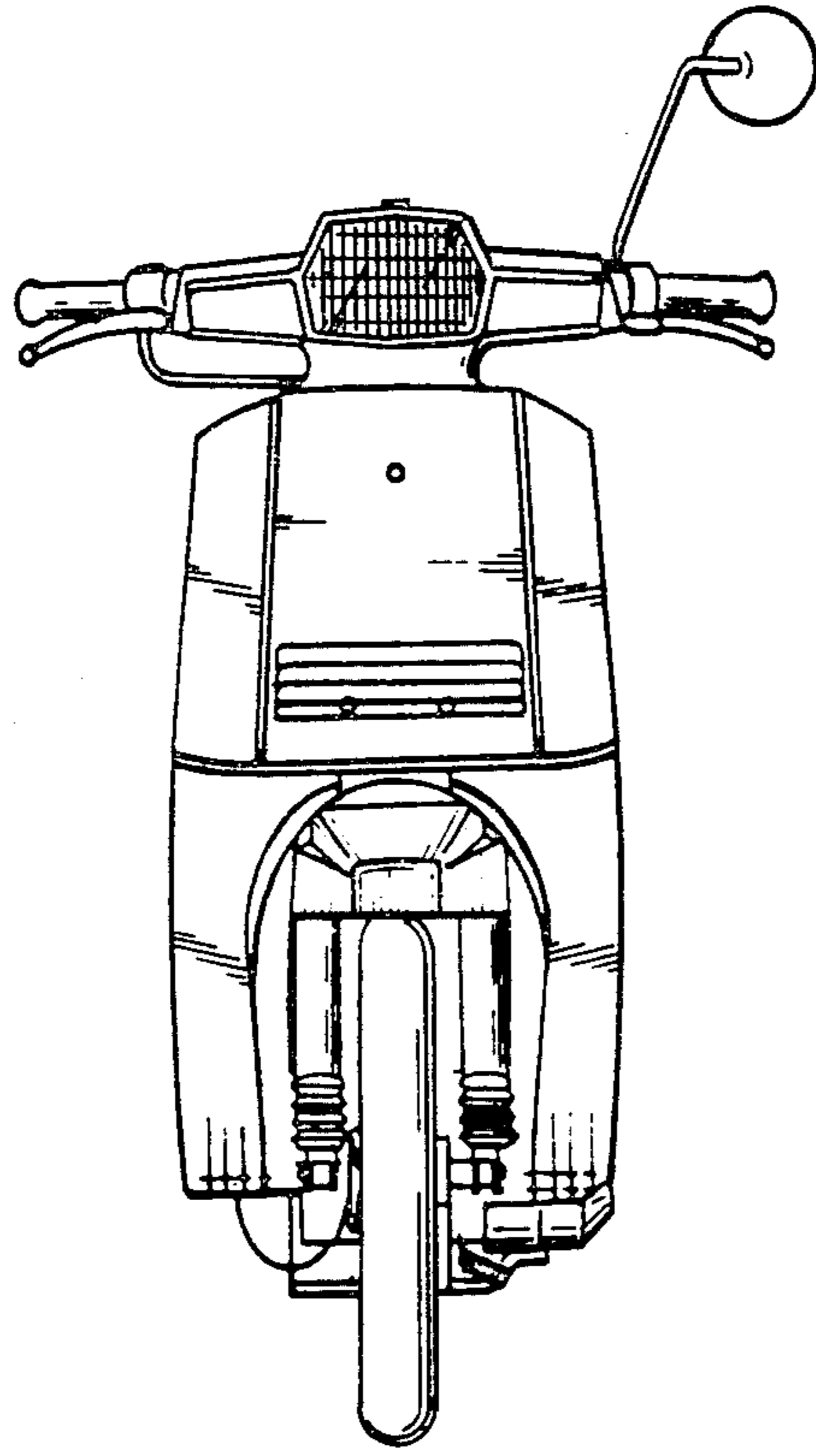

FIG. 1.

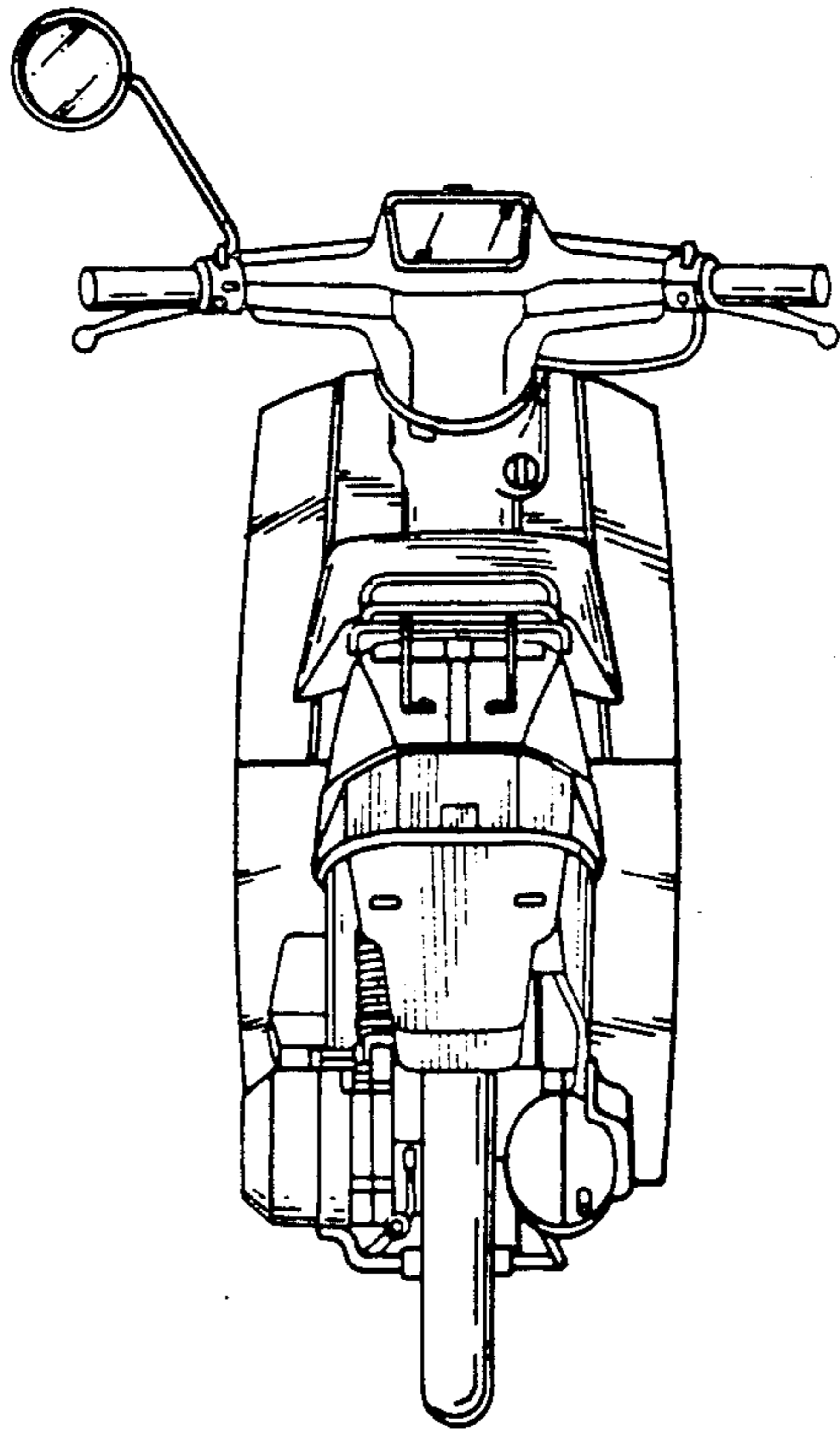

FIG. 2.

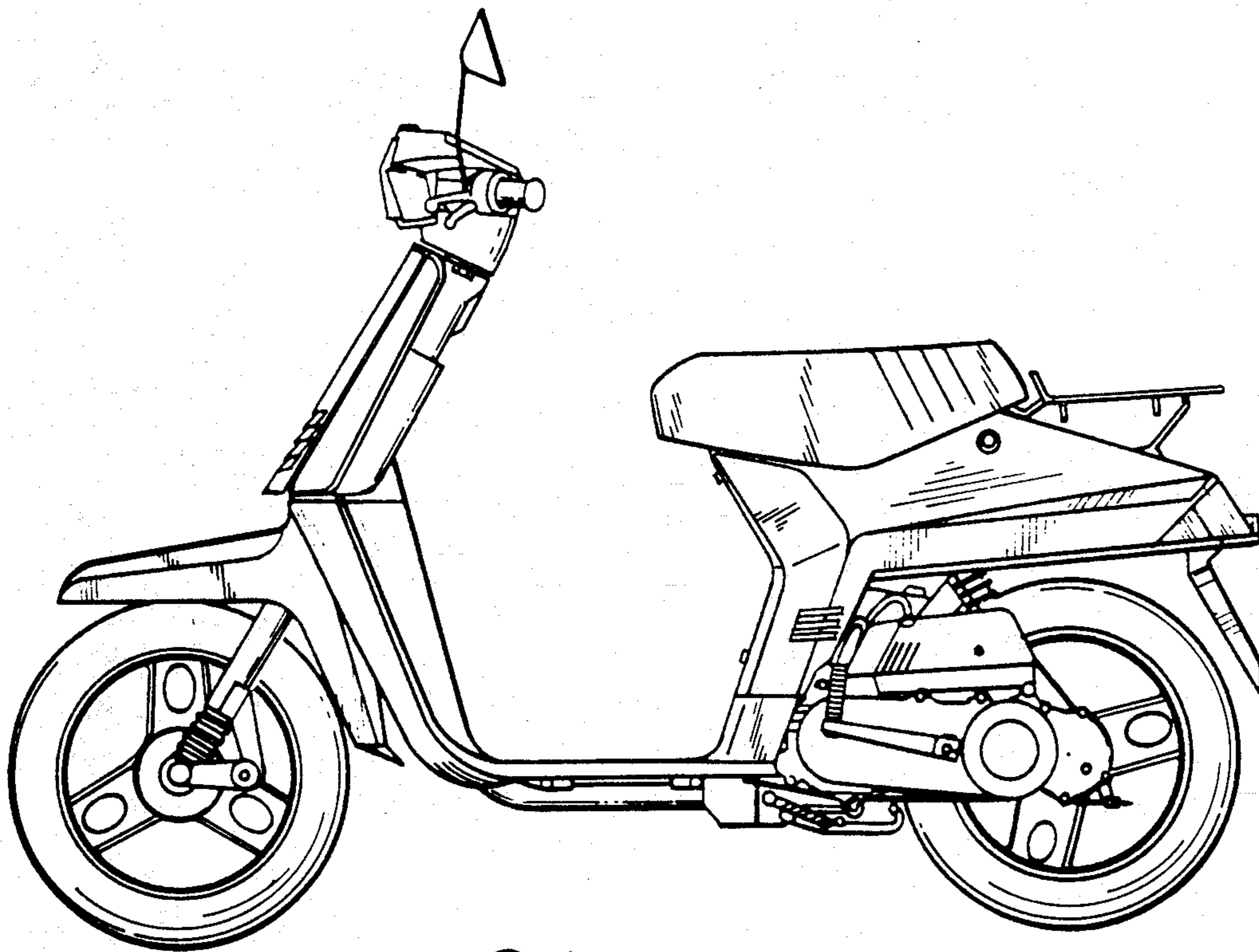

FIG. 3.

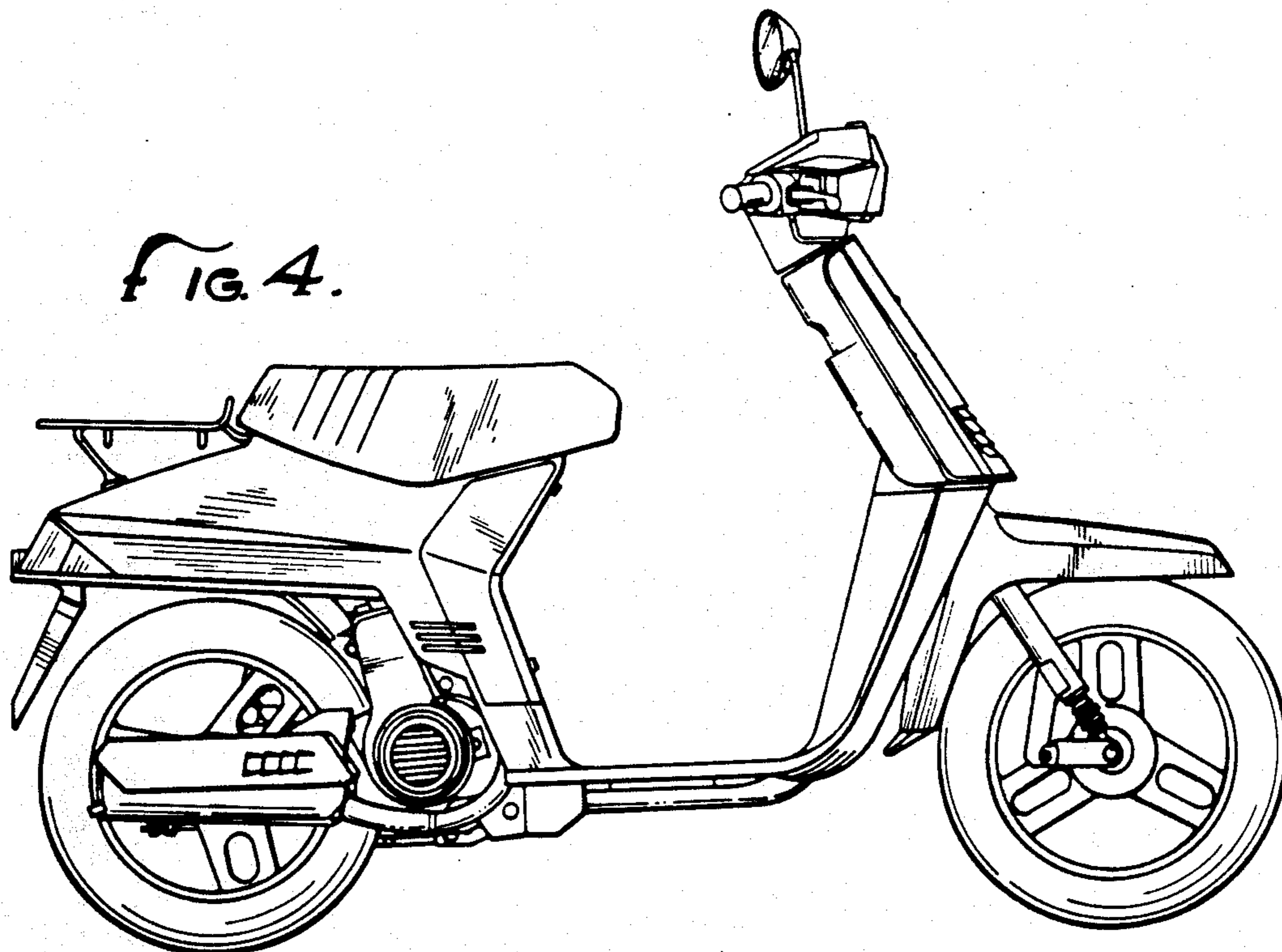

FIG. 4.

FIG. 5.

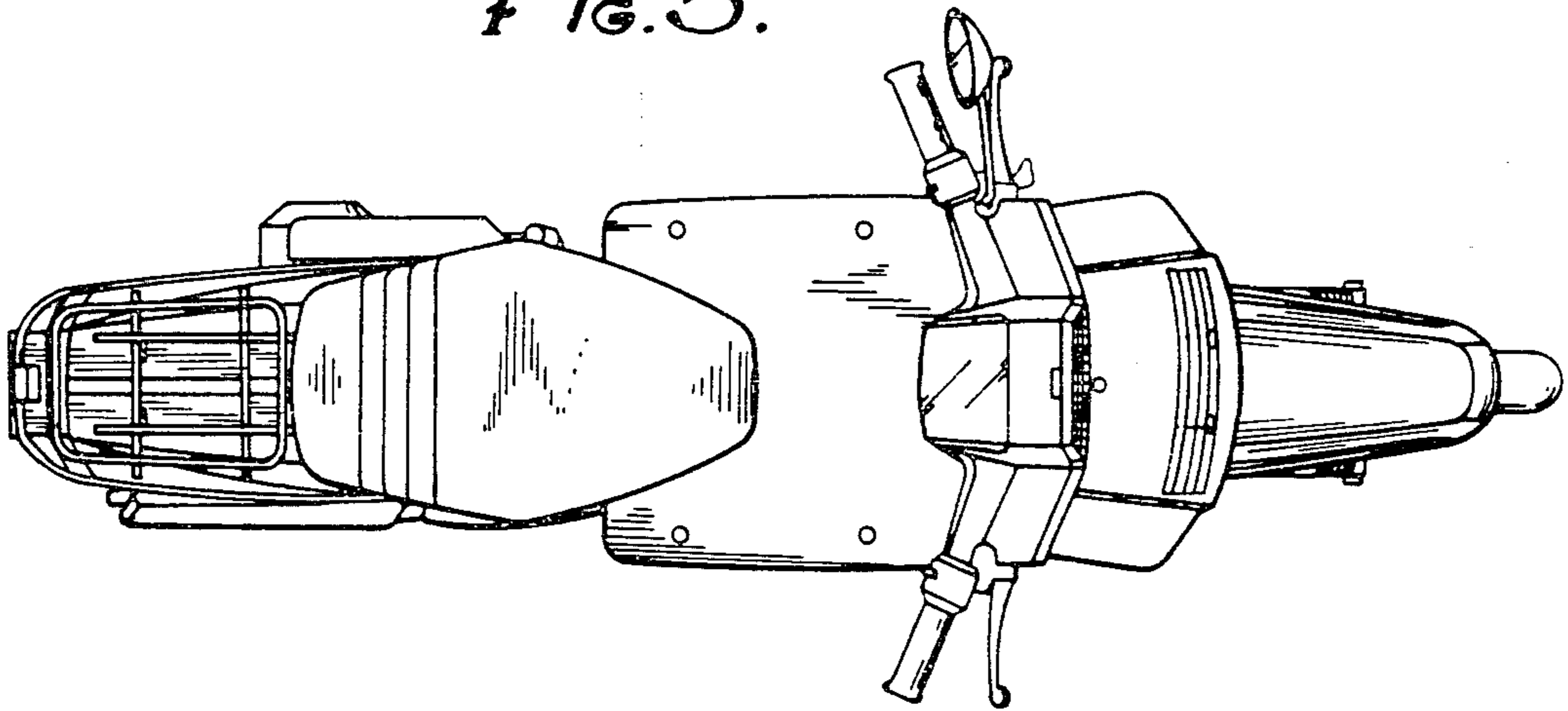
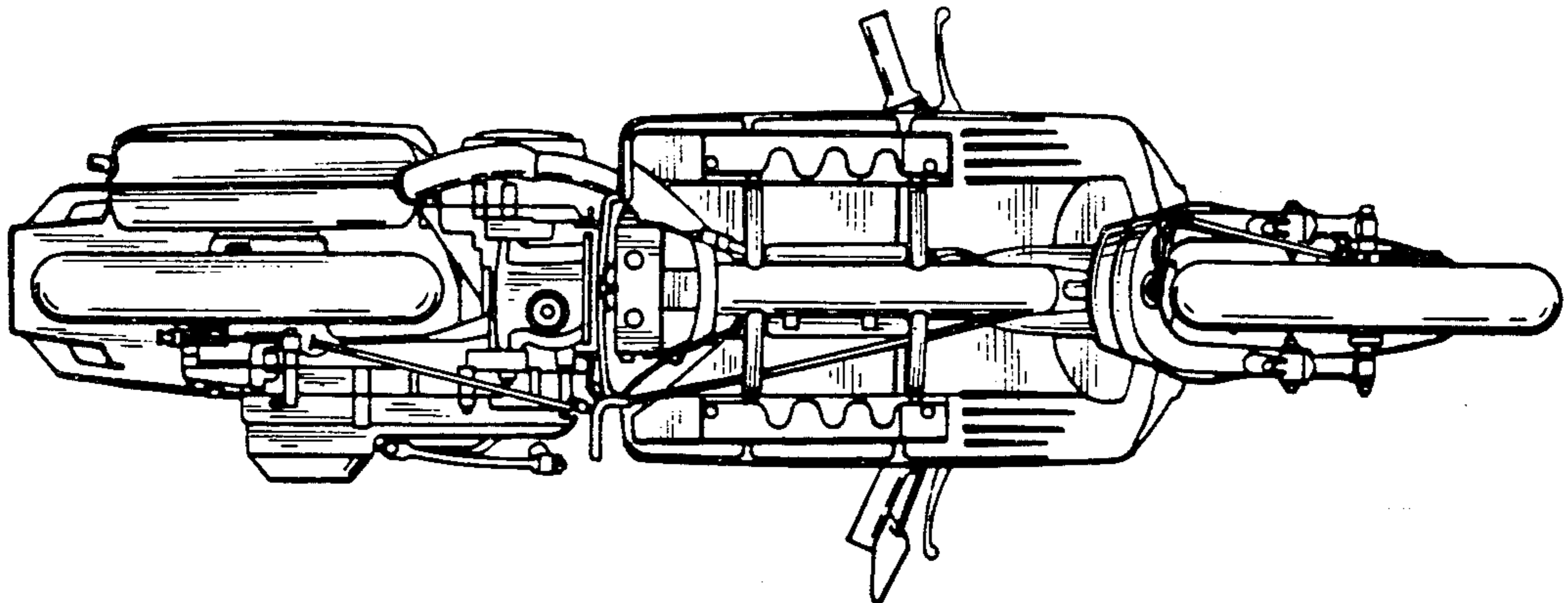

FIG. 6.



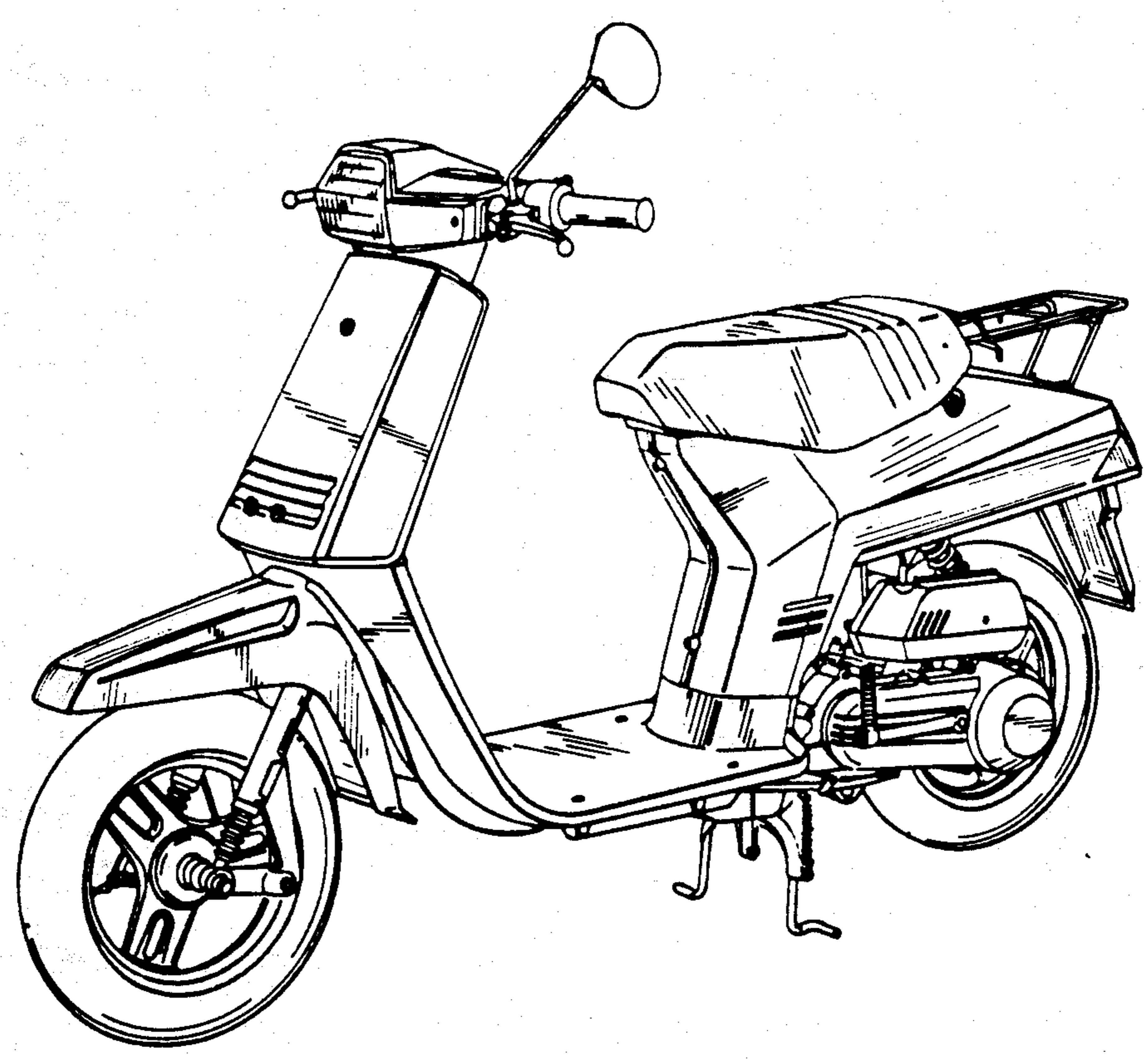

FIG. 7.