

United States Patent [19]

Bott

[11] Patent Number: **Des. 282,155**

[45] Date of Patent: **** Jan. 14, 1986**

[54] **VEHICLE LUGGAGE CARRIER**

[76] Inventor: **John A. Bott, 931 Lakeshore Dr.,
Grosse Pointe Shores, Mich. 48236**

[**] Term: **14 Years**

[21] Appl. No.: **493,945**

[22] Filed: **May 12, 1983**

[52] U.S. Cl. **D12/157**

[58] Field of Search **D12/157; 224/309, 321,
224/325, 327**

[56] **References Cited**

U.S. PATENT DOCUMENTS

D. 264,203 5/1982 Bott D12/157

3,519,180 7/1970 Bott 224/321
4,269,339 5/1981 Bott 224/309
4,448,336 5/1984 Bott 224/309

Primary Examiner—James M. Gandy
Attorney, Agent, or Firm—Harness, Dickey & Pierce

[57] CLAIM

The ornamental design for a vehicle luggage carrier, as shown and described.

DESCRIPTION

FIG. 1 is an elevated perspective view of the vehicle luggage carrier;
FIG. 2 is a top plan view thereof;
FIG. 3 is a side elevational view thereof; and
FIG. 4 is an end elevational view thereof.

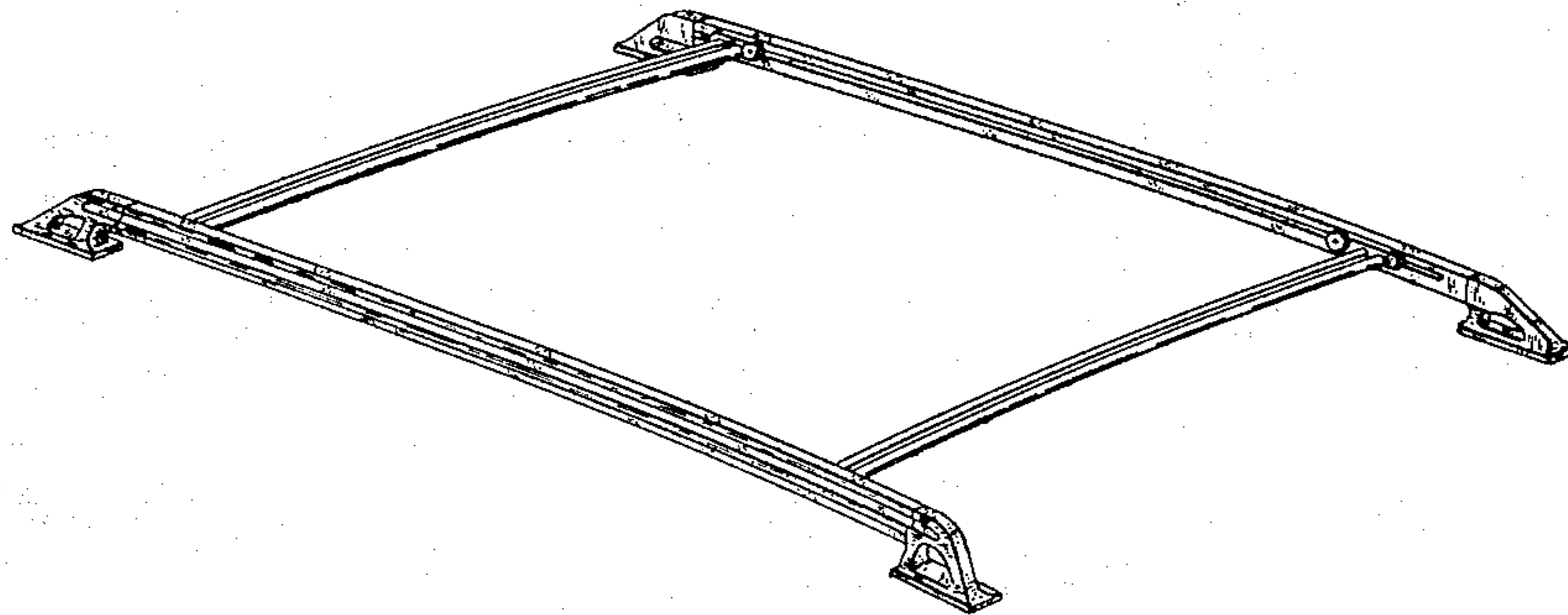

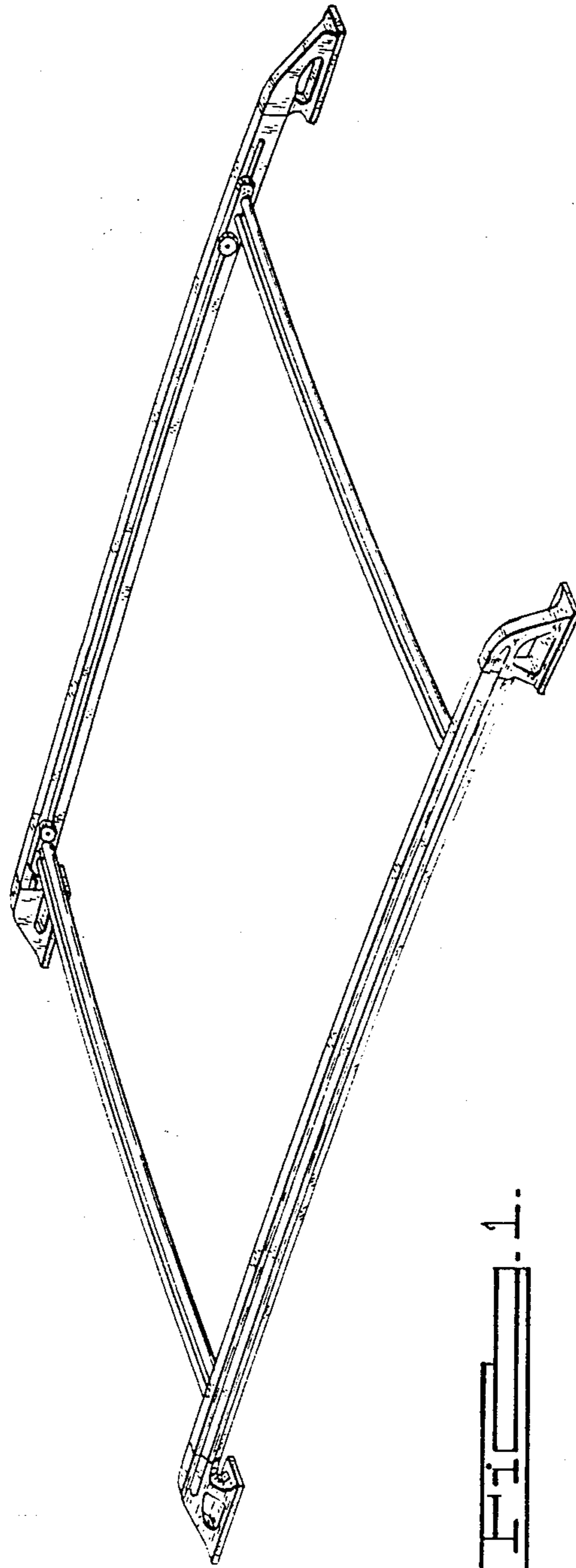

FIG. 1

FIG. 2.

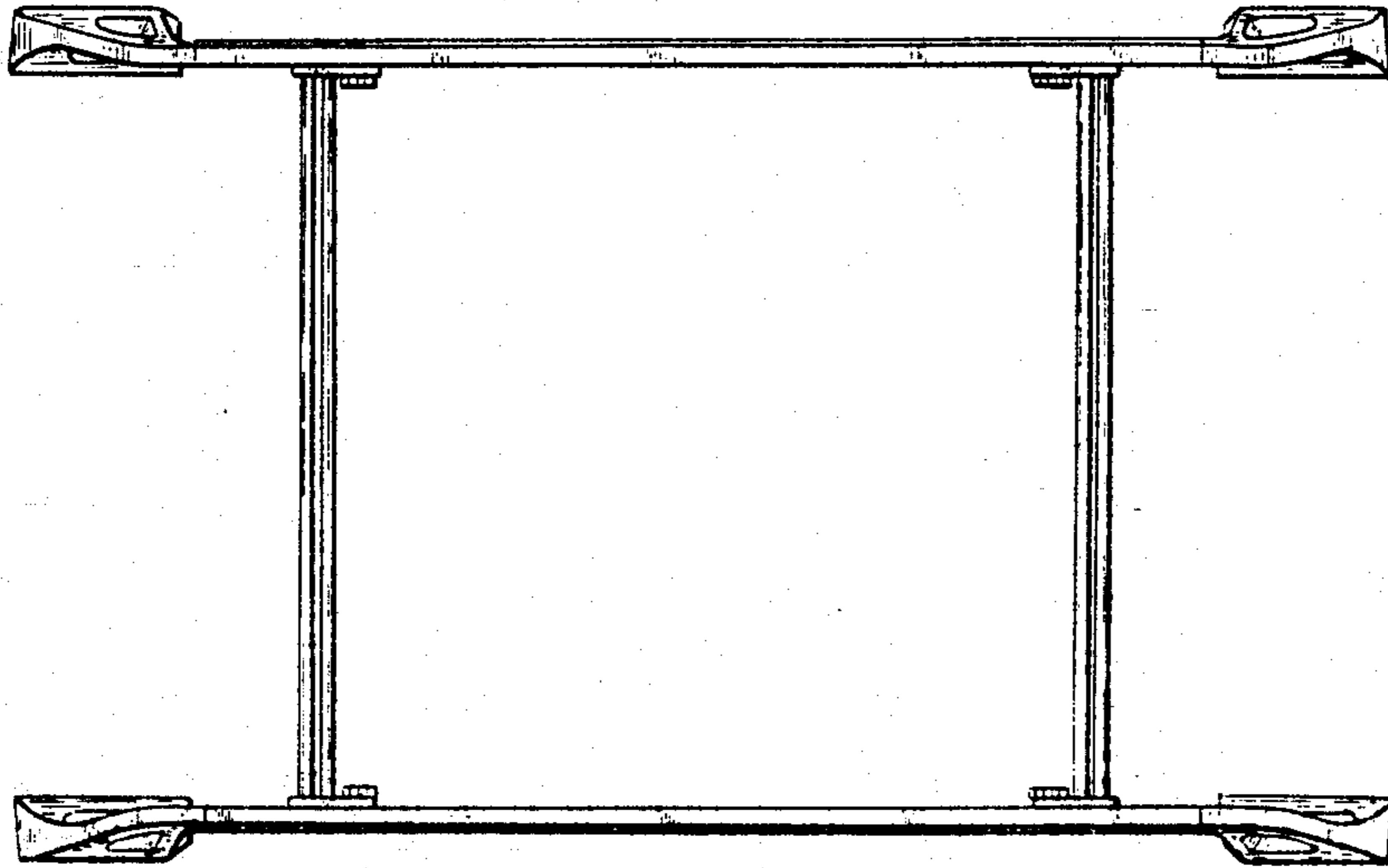

FIG. 3.

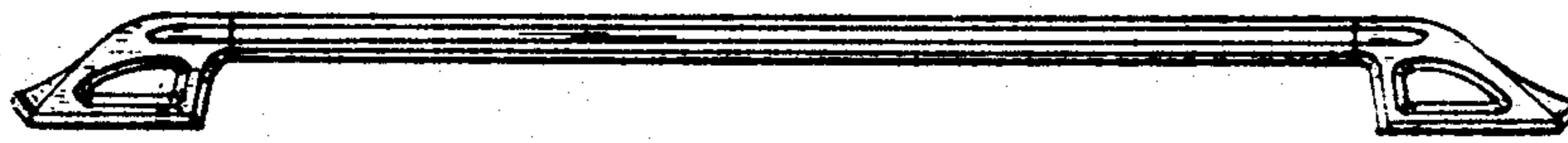

FIG. 4.

