

[54] TOY VAN

[75] Inventors: Frederick H. Kroll, 72 Wood Hollow La., New Rochelle, N.Y. 10804; Rosalind M. Fox, Indialantic, Fla.

[73] Assignee: Frederick H. Kroll, New Rochell, N.Y.

[**] Term: 14 Years

[21] Appl. No.: 491,729

[22] Filed: May 5, 1983

[52] U.S. Cl. D21/78

[58] Field of Search D21/76, 78, 79, 80, D21/81, 128, 131, 132, 133, 134, 135, 136, 137, 139, 140; 280/87.01, 87.02 R, 87.1, 87.2; 446/440, 451, 465, 466

[56] References Cited

U.S. PATENT DOCUMENTS

D. 228,398 9/1973 Campenell D21/78

D. 231,665 5/1974 Spiegel D21/134
D. 259,730 6/1981 Arad et al. D21/78
D. 274,442 6/1984 Appel et al. D21/78
4,430,827 2/1984 Rice et al. 446/465

Primary Examiner—Charles A. Rademaker
Attorney, Agent, or Firm—McAulay, Fields, Fisher, Goldstein & Nissen

[57] CLAIM

The ornamental design for a toy van, as shown and described.

DESCRIPTION

FIG. 1 is a top plan view of a toy van showing our new design;
FIG. 2 is a front elevational view thereof;
FIG. 3 is a bottom plan view thereof;
FIG. 4 is a right side elevational view thereof;
FIG. 5 is a left side elevational view thereof;
FIG. 6 is a rear elevational view thereof; and
FIG. 7 is a perspective view showing the rear portion in the open position.

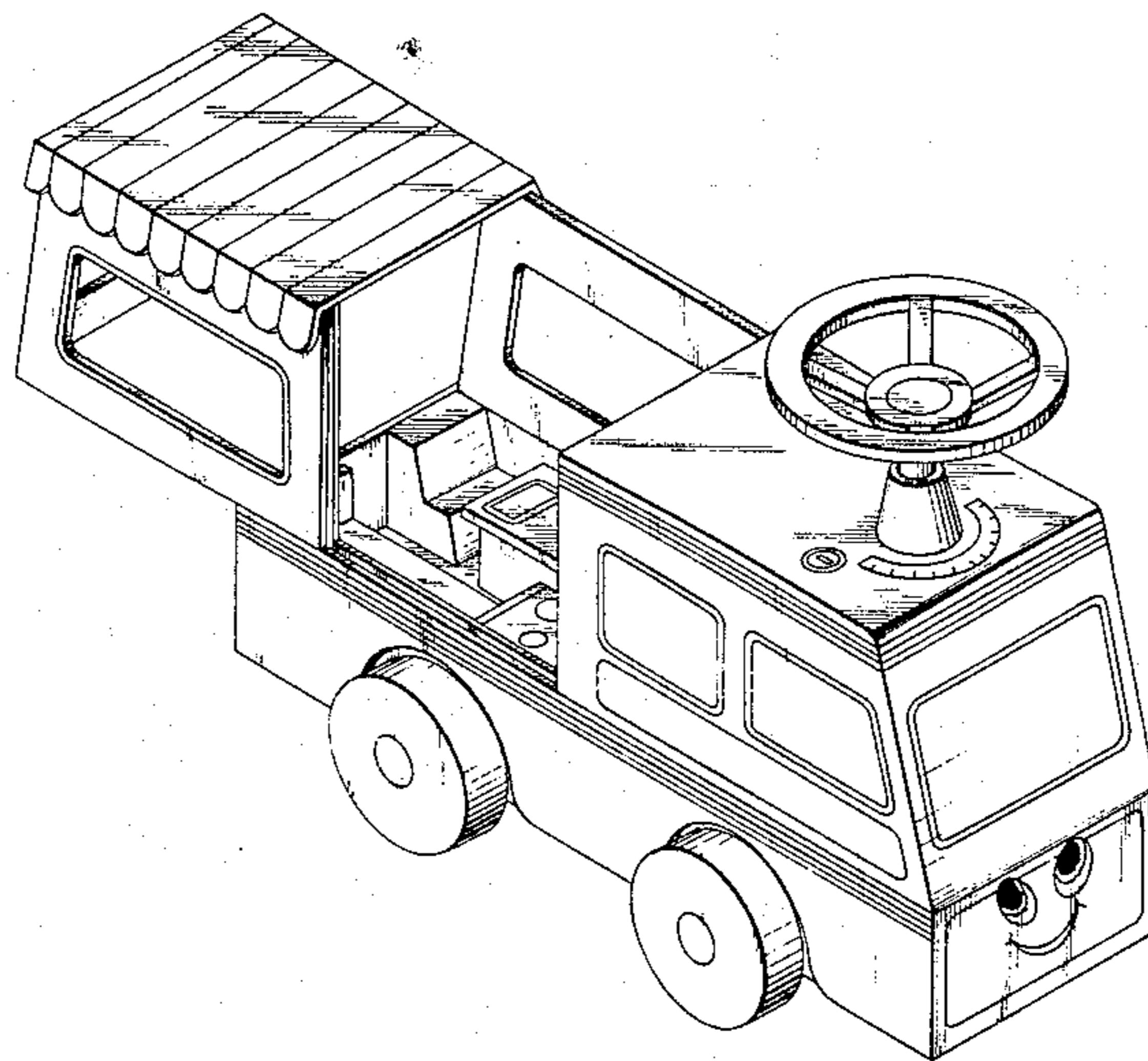

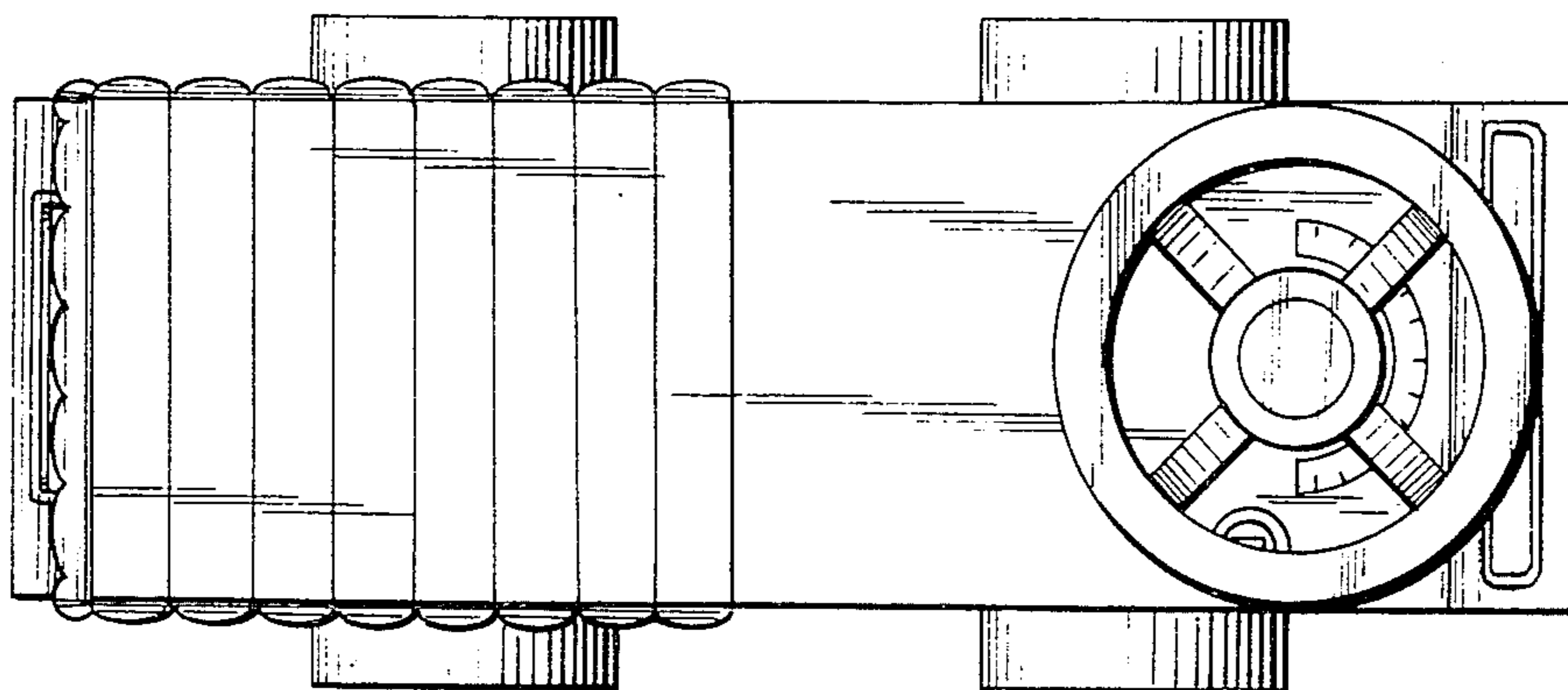

FIG. 1

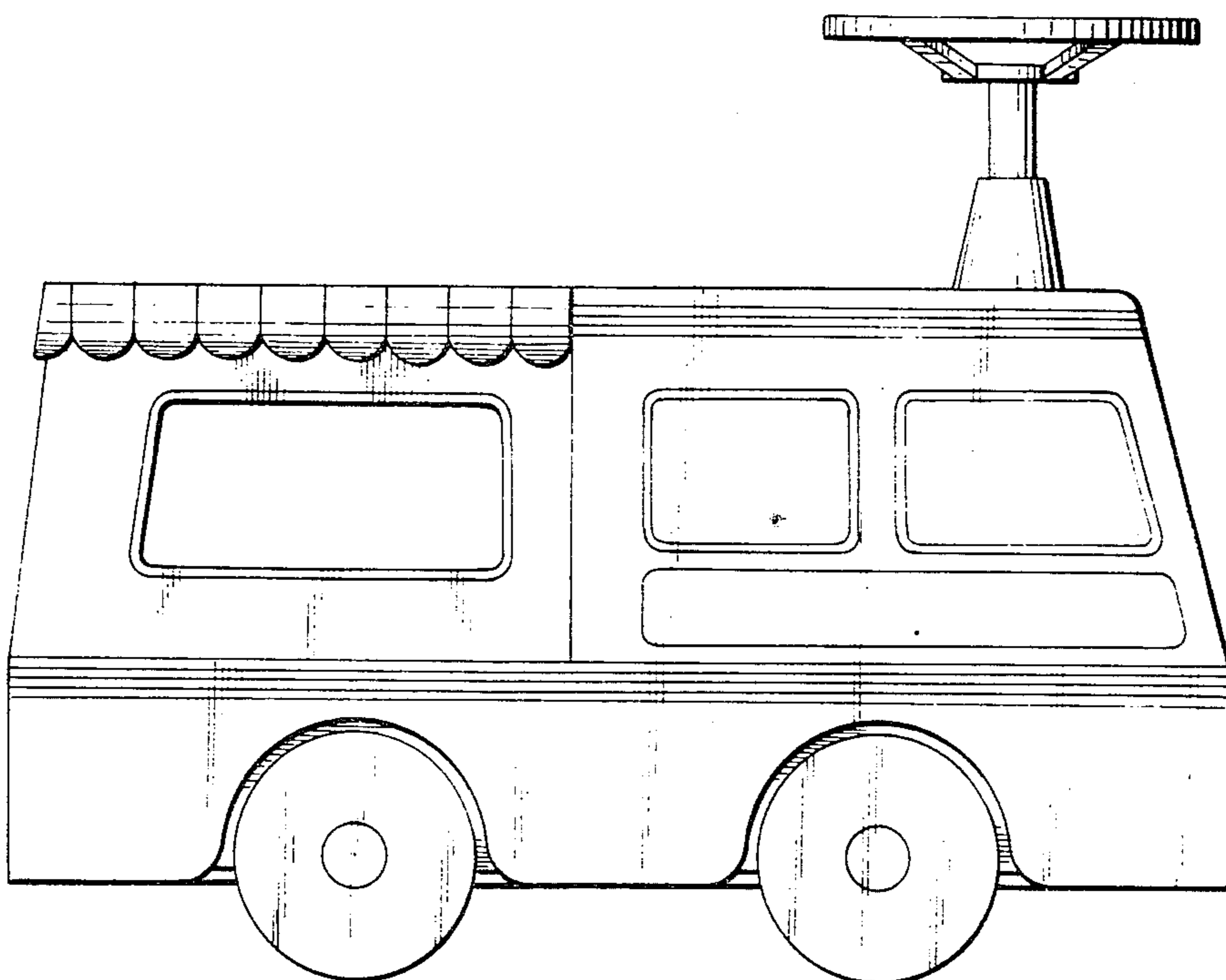

FIG. 2

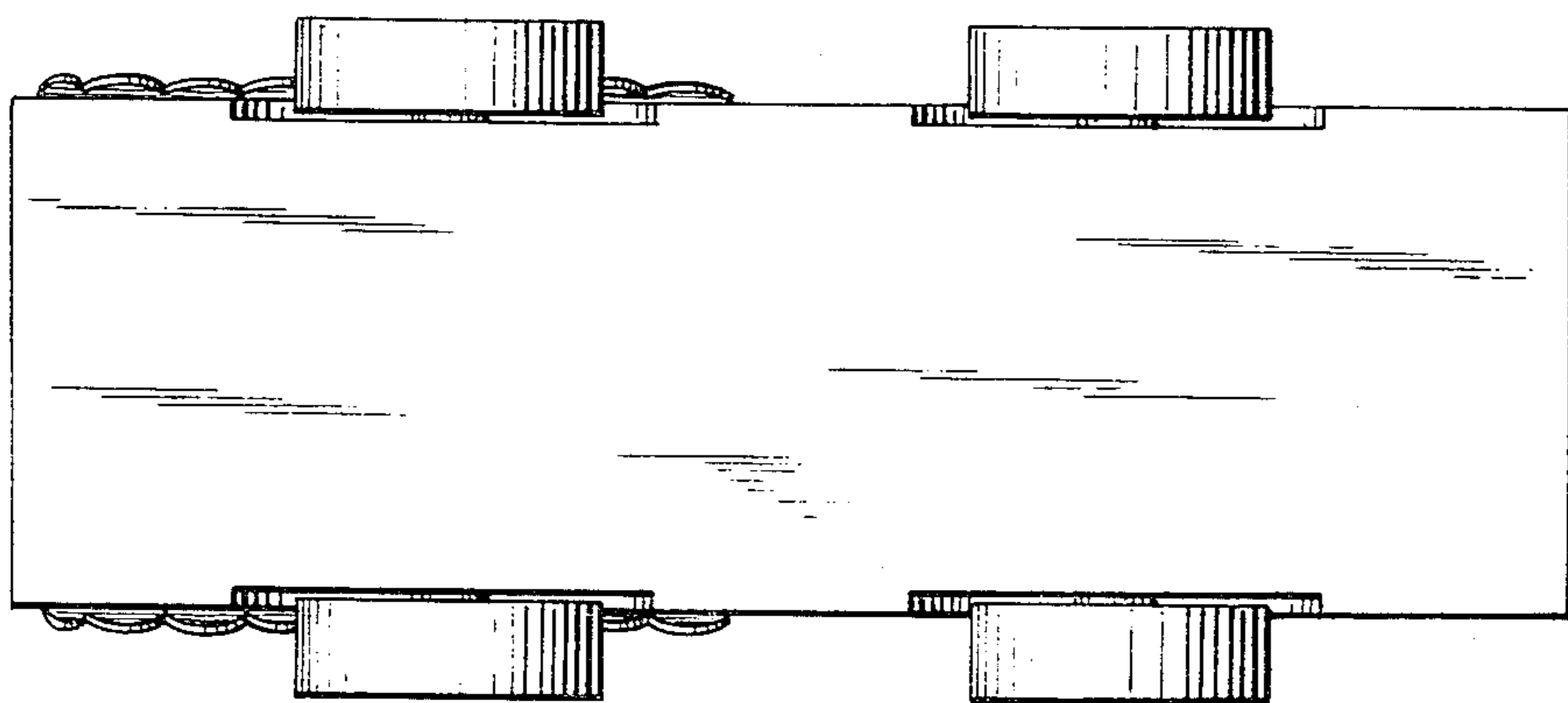

FIG. 3

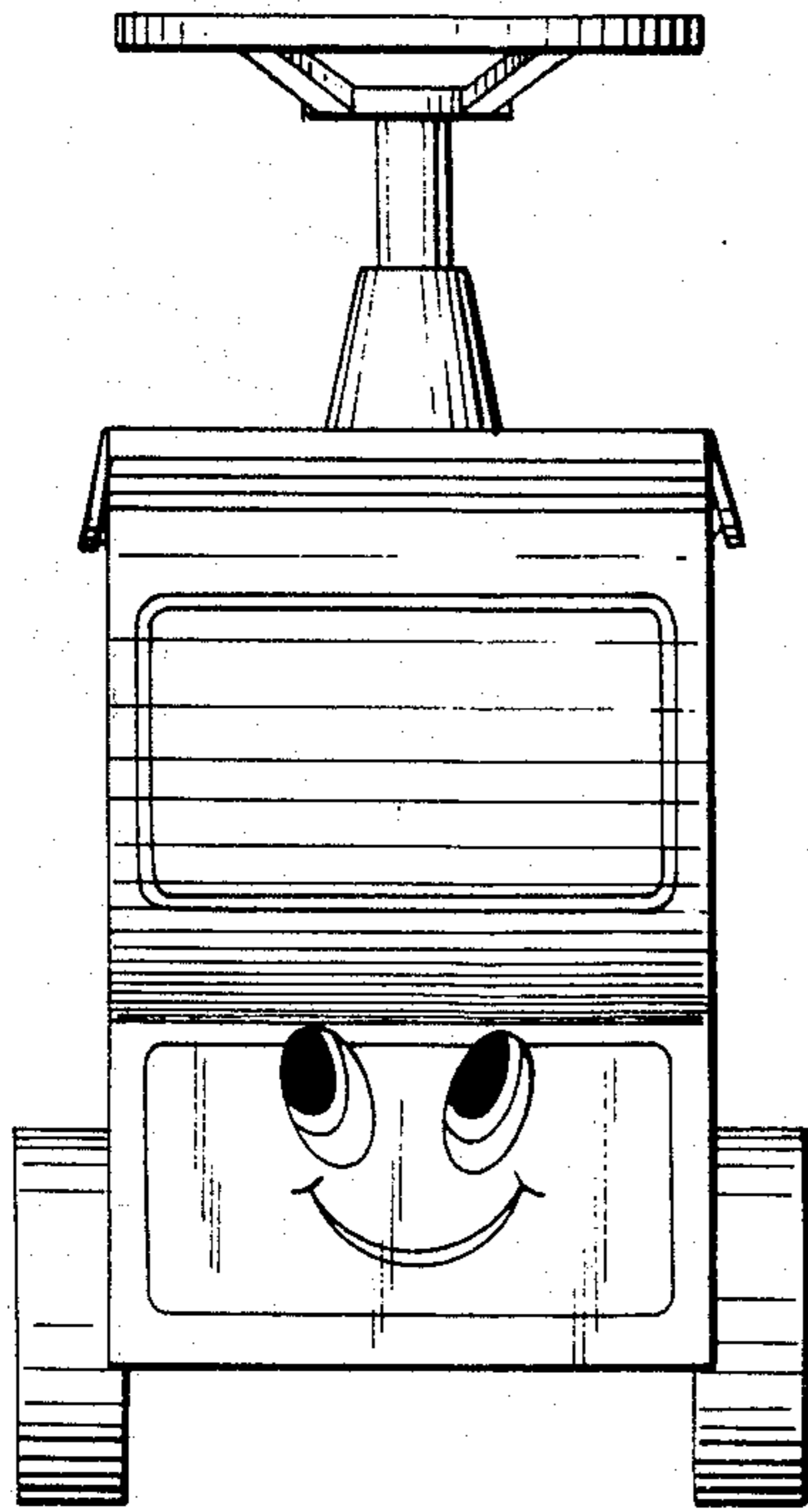

FIG. 4

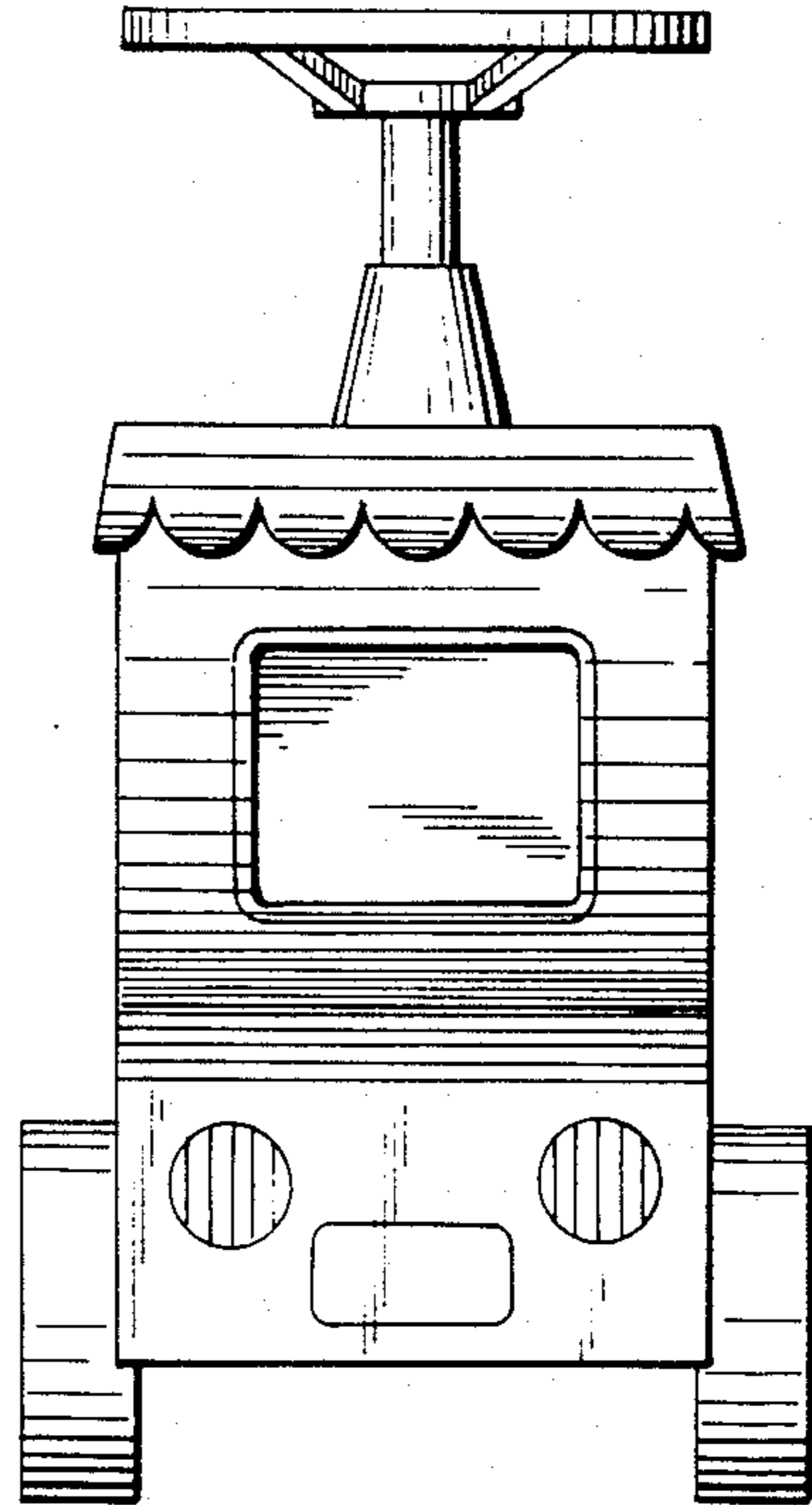

FIG. 5

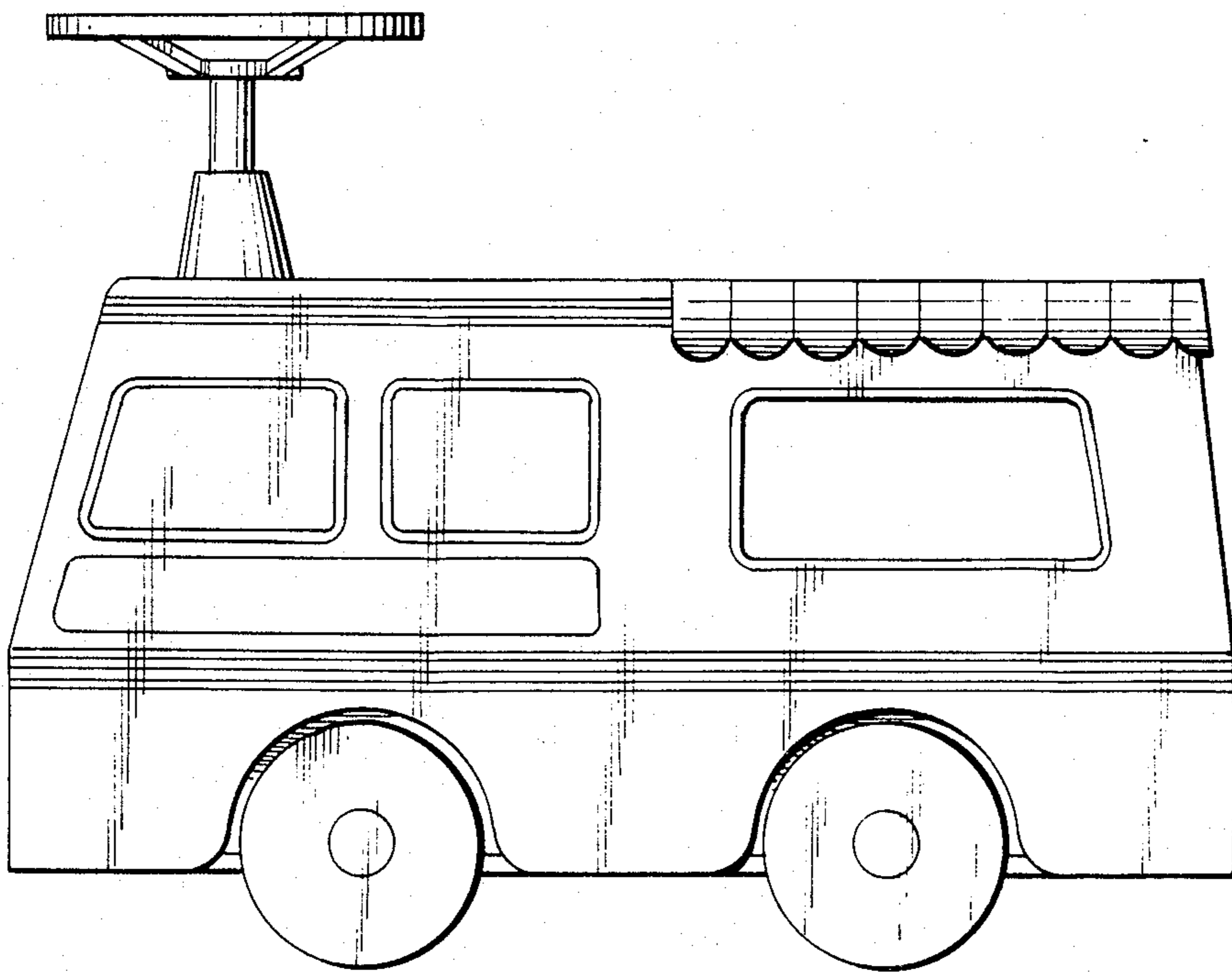

FIG. 6

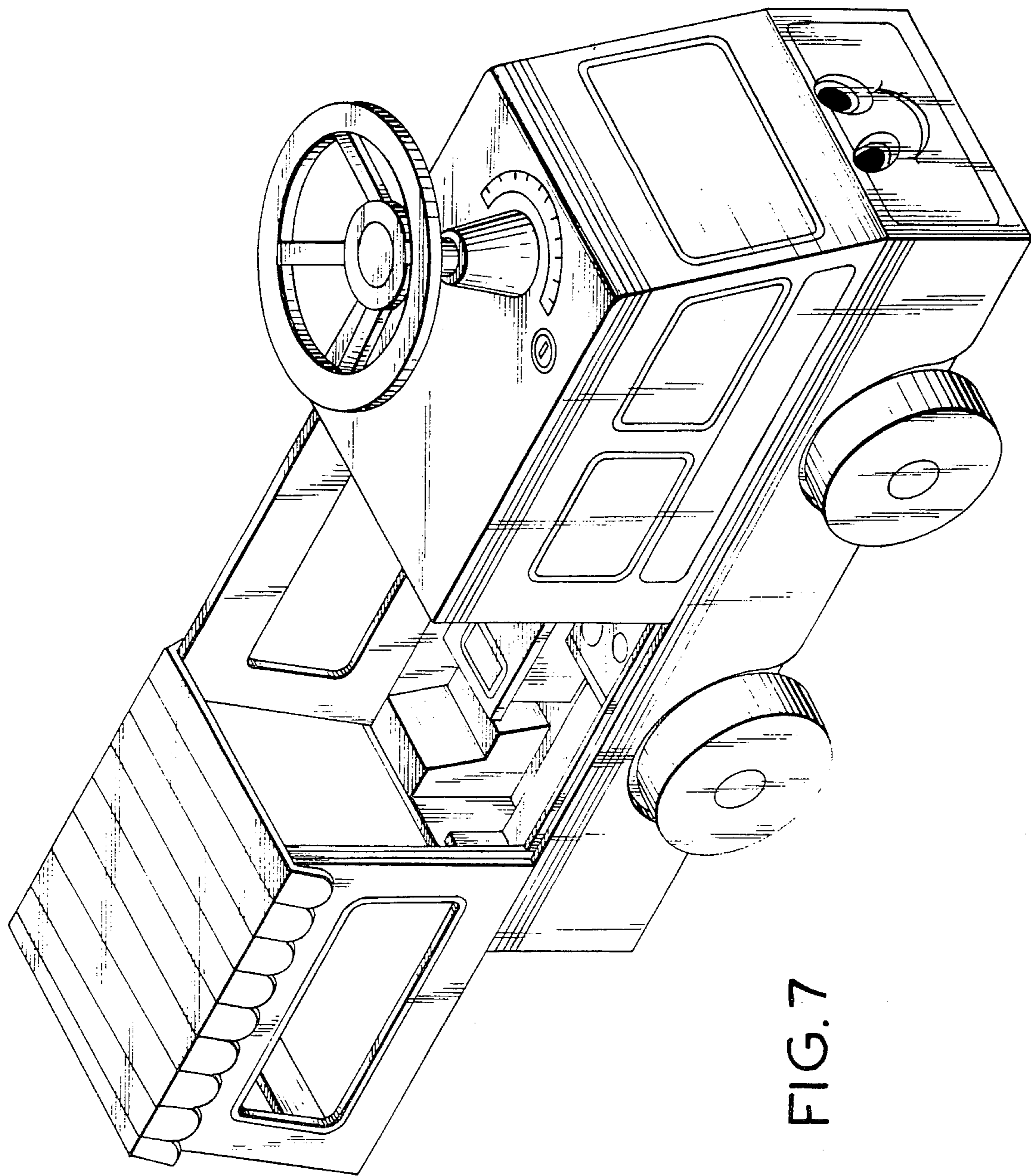

FIG. 7