

[54] ROTATING HEAD FOR DRILLING  
[75] Inventors: Robert M. Bearden, Fort Smith; W. A. Haynes, Greenwood, both of Ark.

3,052,300 9/1962 Hampton ..... 166/84  
4,312,404 1/1982 Morrow ..... 166/84  
4,363,357 12/1982 Hunter ..... 166/84  
4,398,599 8/1983 Murray ..... 166/84 X

[73] Assignee: Arkoma Machine Shop, Inc., Fort Smith, Ark.

Primary Examiner—James R. Largen  
Attorney, Agent, or Firm—Dunlap, Coddling & Peterson

[\*\*] Term: 14 Years

[57] CLAIM

[21] Appl. No.: 468,933

The ornamental design for a rotating head for drilling, as shown.

[22] Filed: Feb. 23, 1983

[52] U.S. Cl. .... D15/21

[58] Field of Search ..... D23/40-47;  
D15/21; 166/78, 84; 175/207, 214

DESCRIPTION

FIG. 1 is a left side elevational view of a rotating head for drilling showing our new design; FIG. 2 is a right side elevational view thereof; FIG. 3 is a top plan view thereof; FIG. 4 is a rear elevational view thereof; FIG. 5 is a front elevational view thereof; and FIG. 6 is a bottom plan view thereof.

[56] References Cited

U.S. PATENT DOCUMENTS

2,124,840 7/1938 Wrigley ..... 166/84

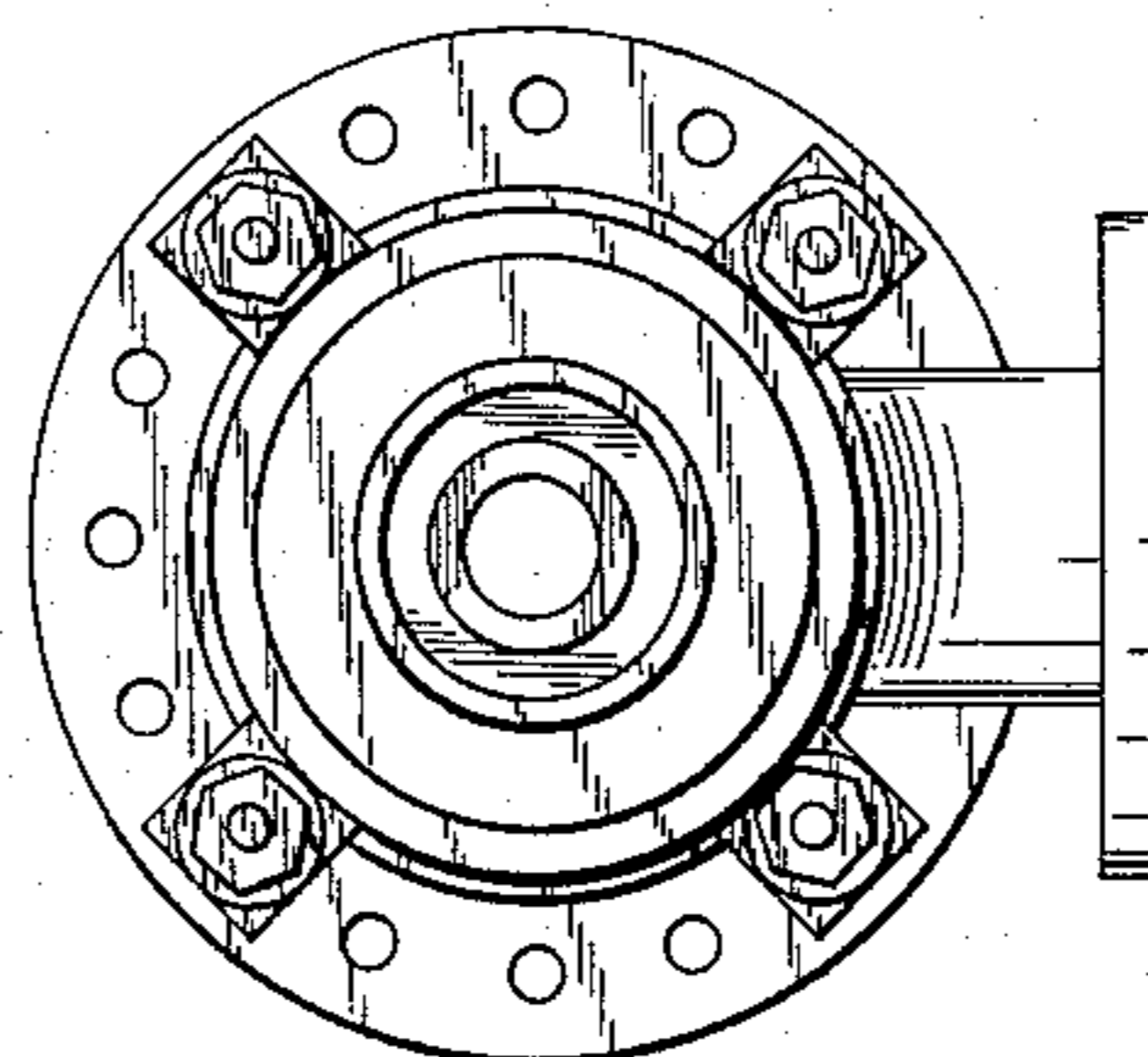
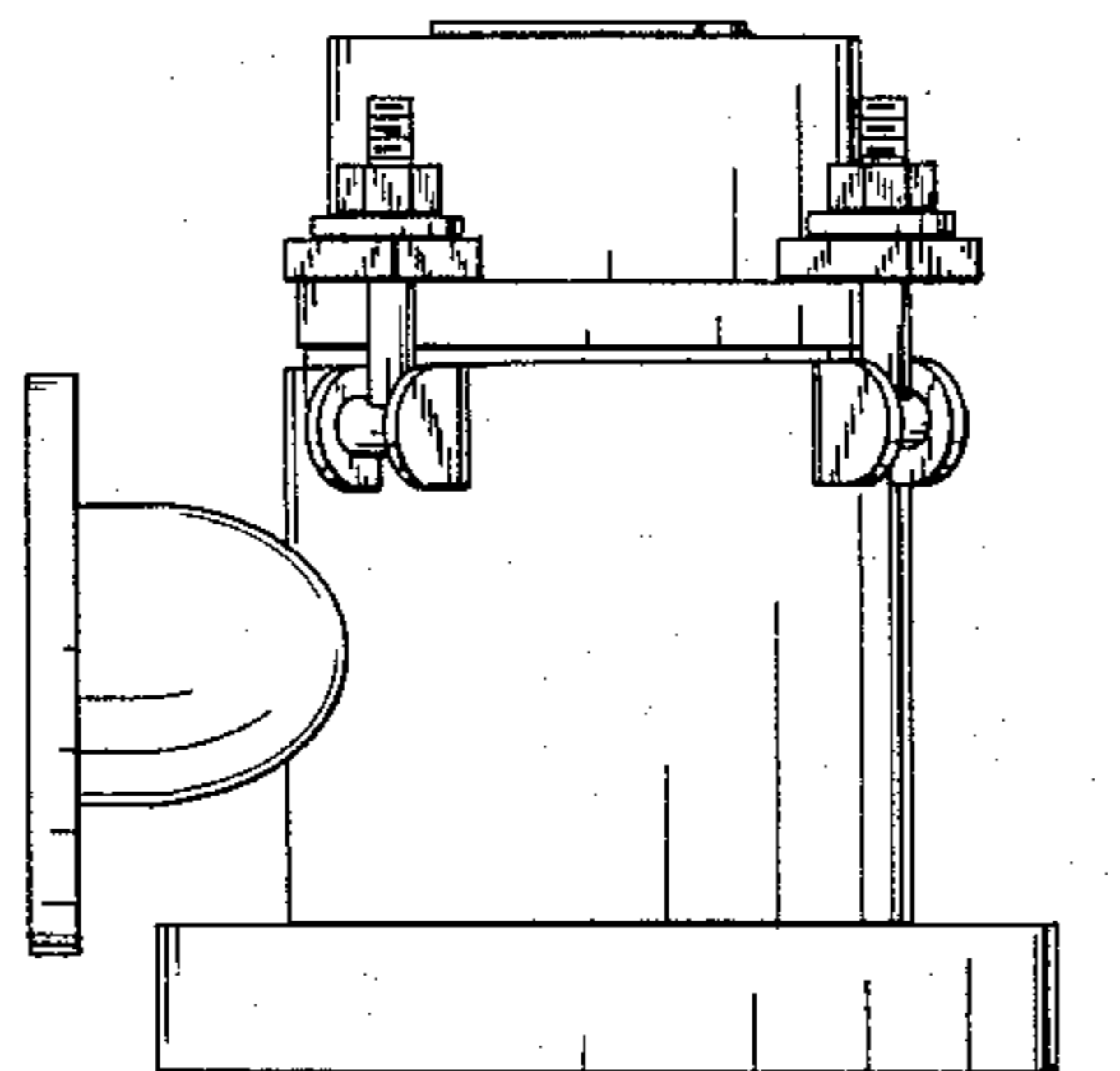

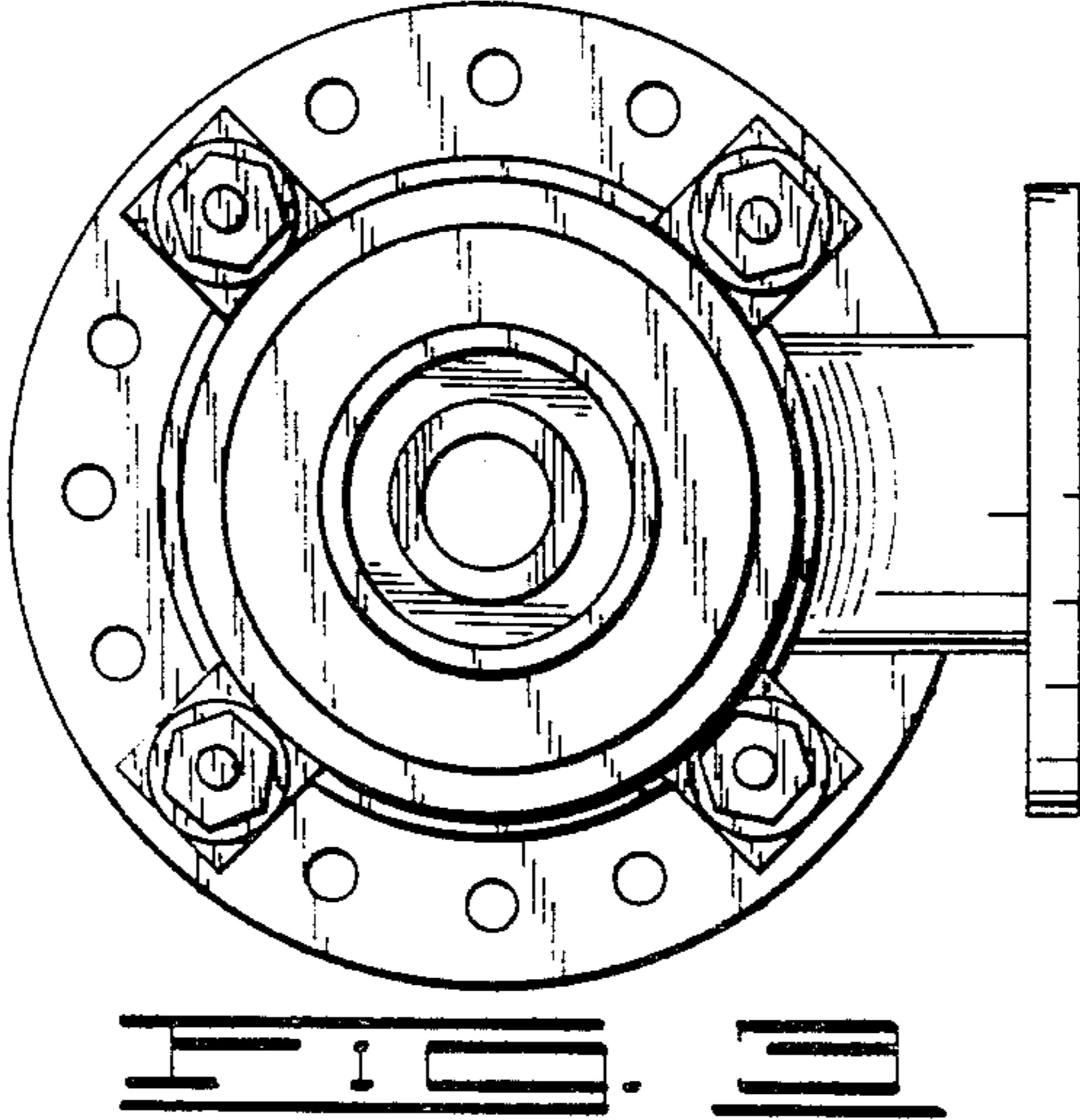
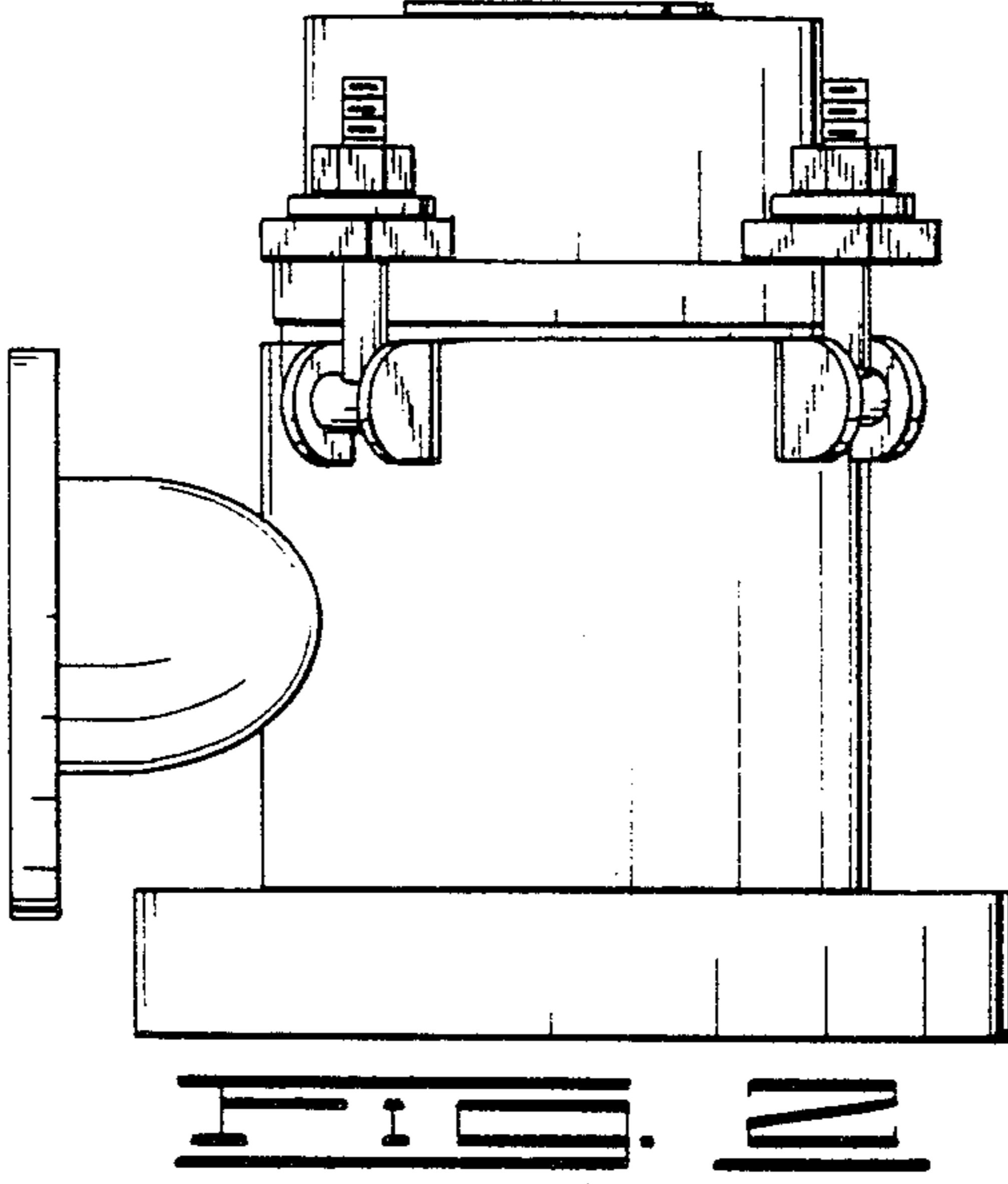
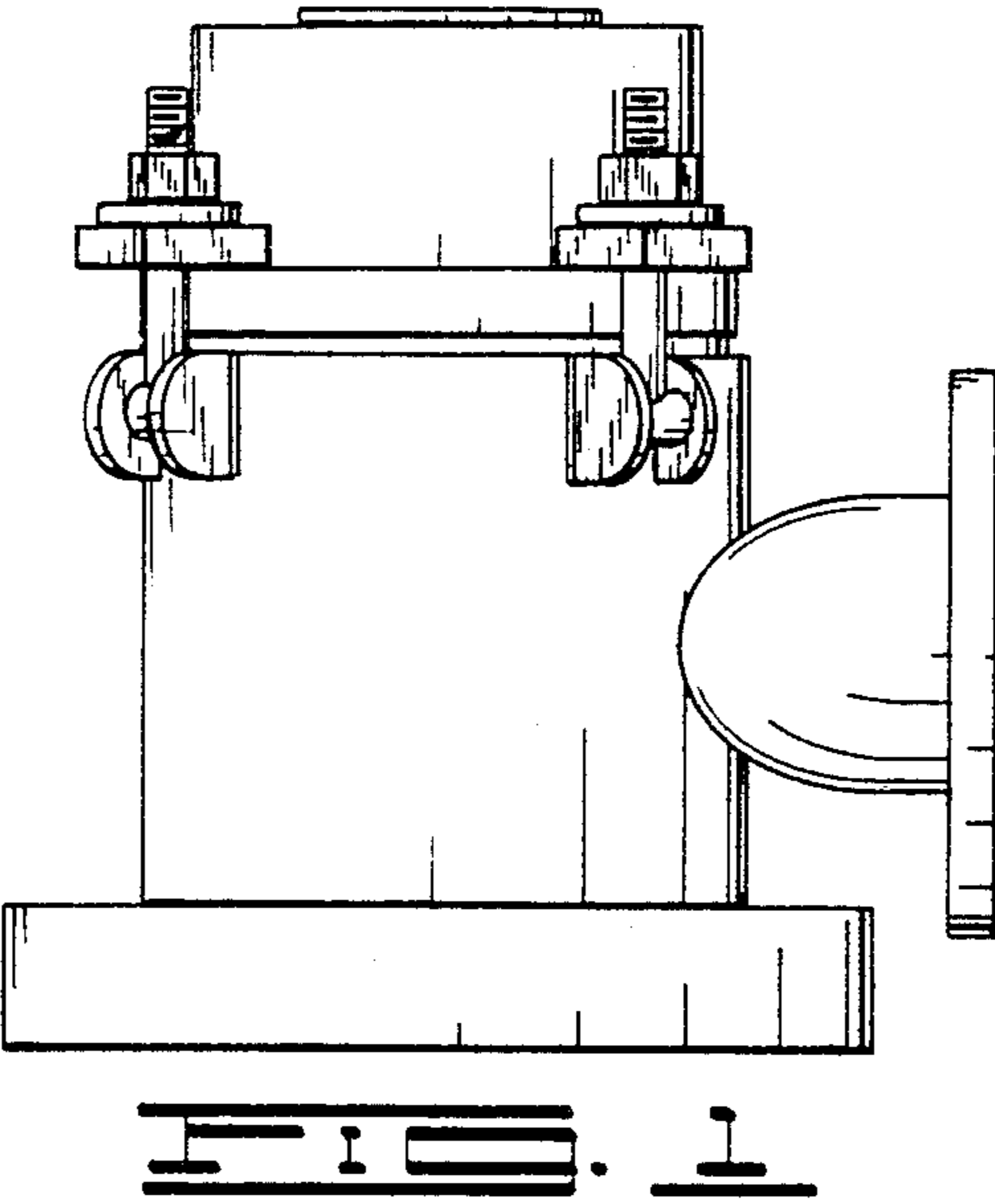

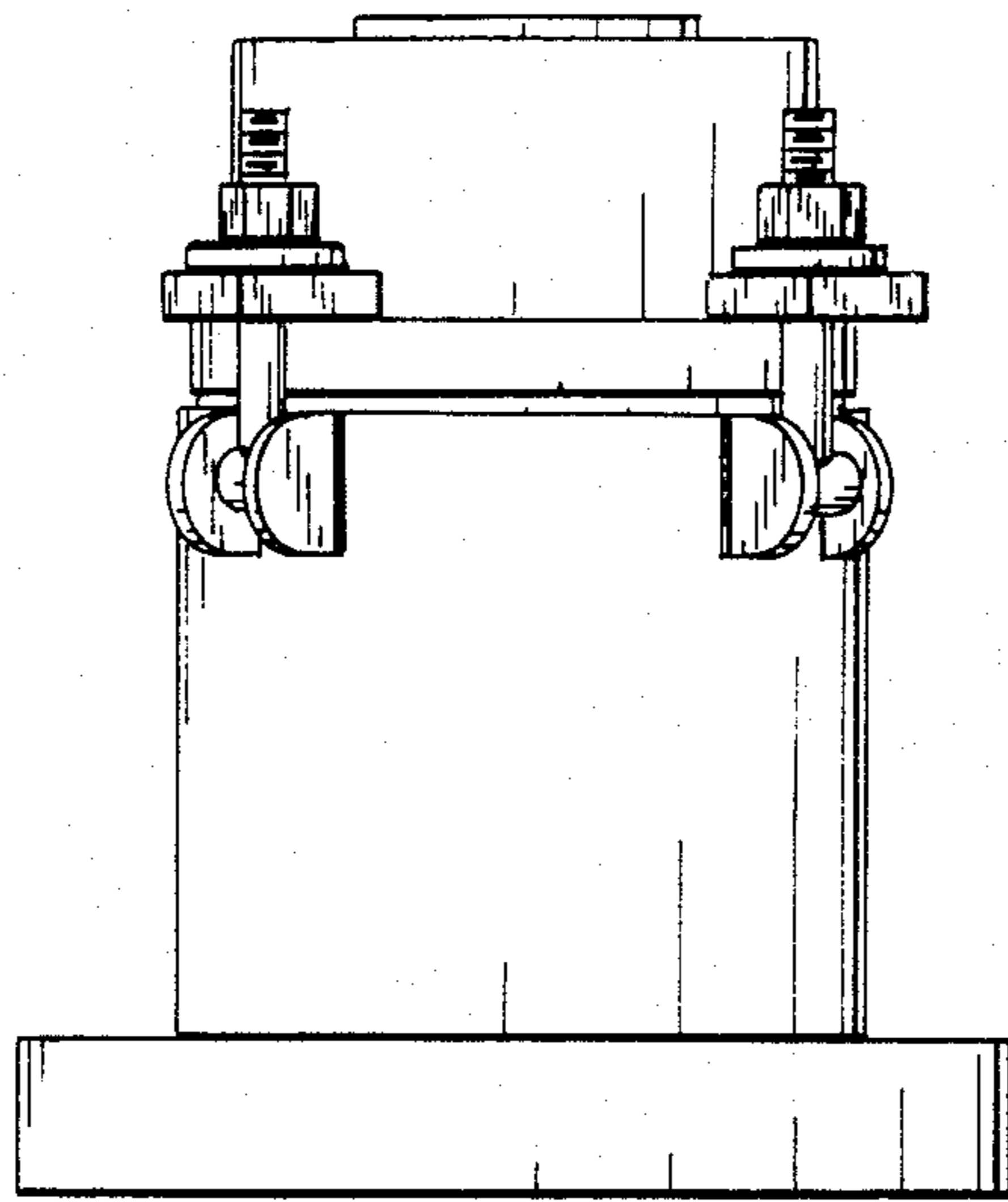

FIG. 4

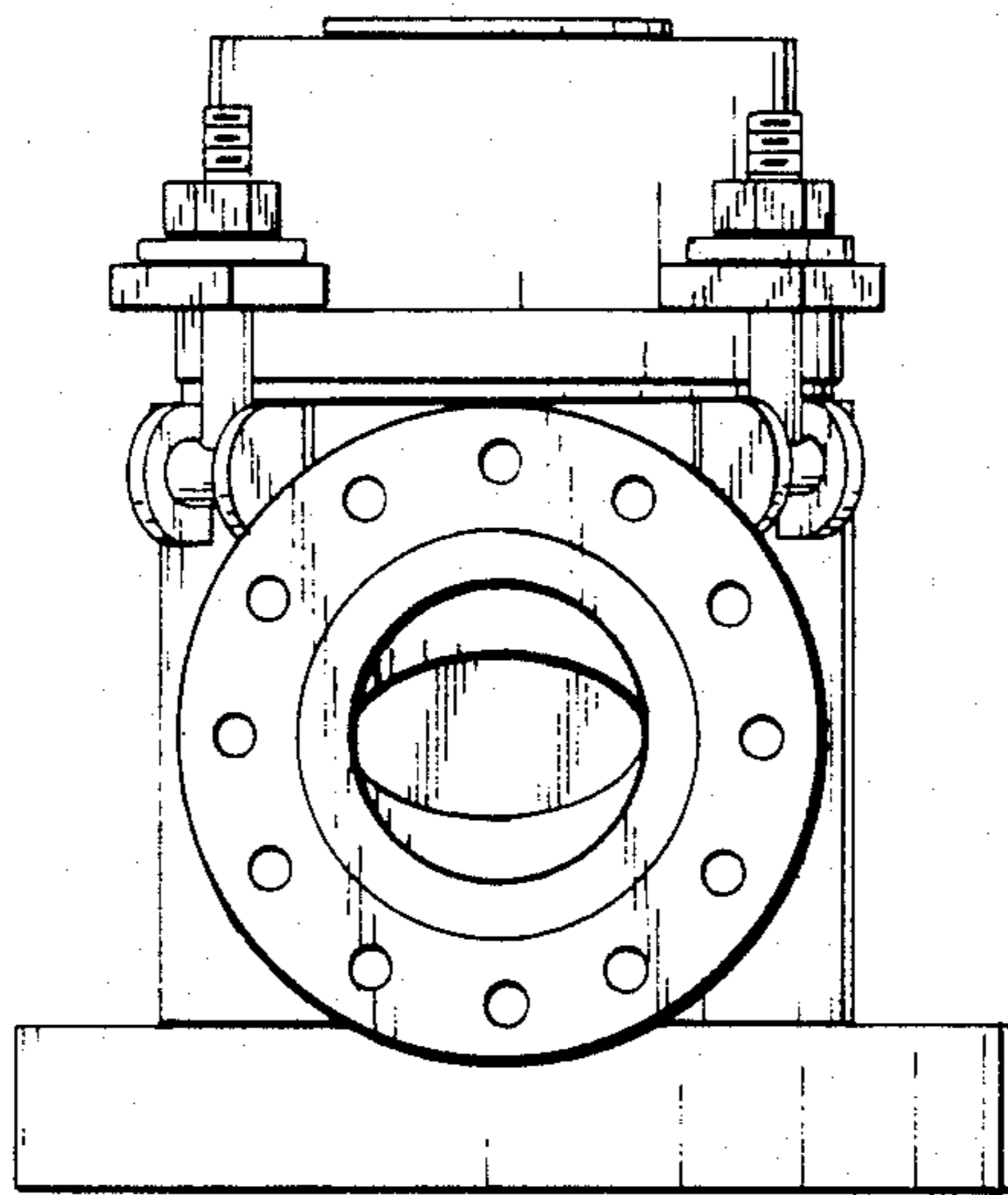

FIG. 5

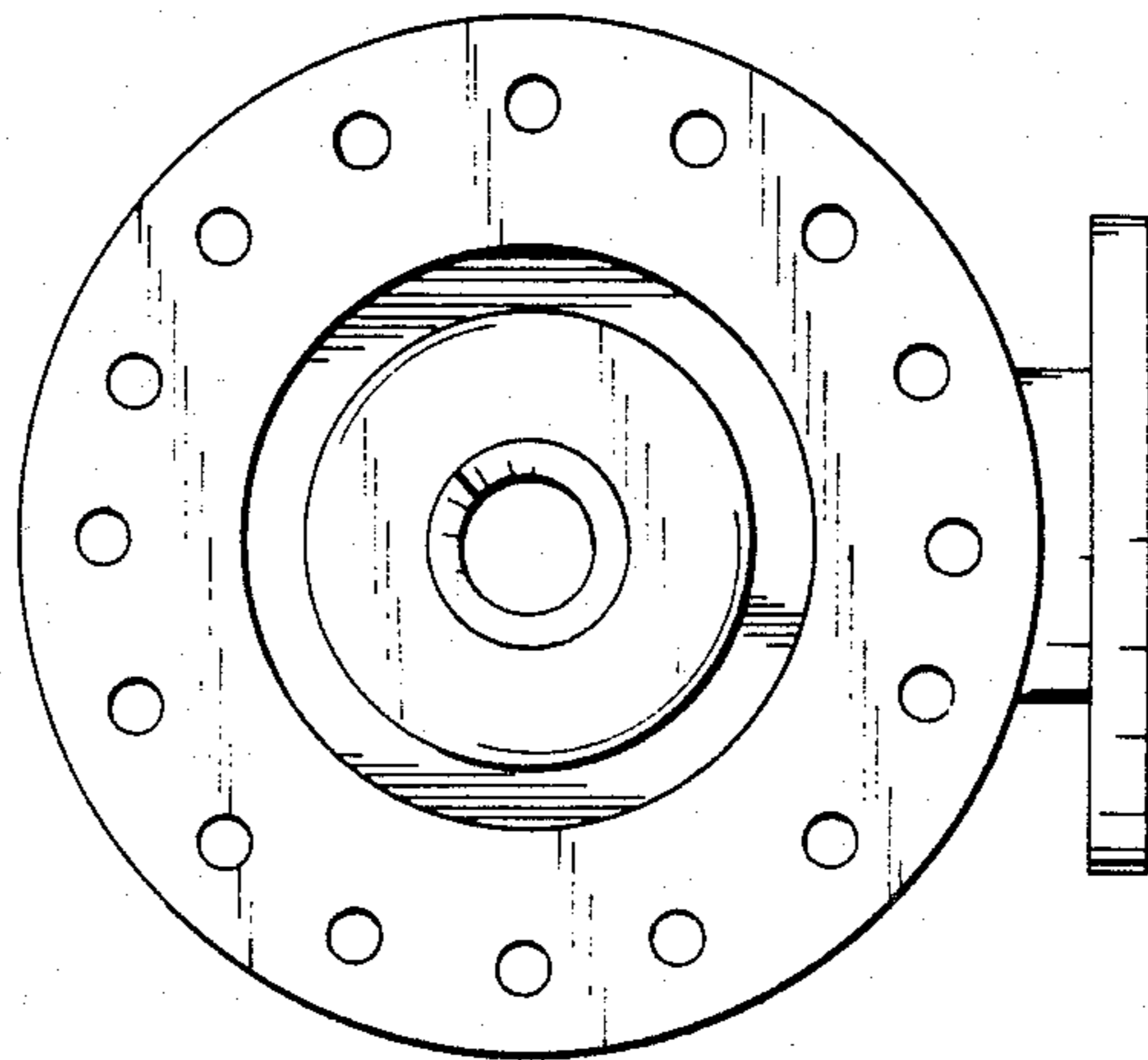

FIG. 6