

[54] SEWING MACHINE

[75] Inventor: Willi Meier, Karlsruhe-Durlach, Fed. Rep. of Germany

[73] Assignee: Firma Dorina Nähmaschinen GmbH, Fed. Rep. of Germany

[**] Term: 14 Years

[21] Appl. No.: 470,514

[22] Filed: Feb. 28, 1983

[30] Foreign Application Priority Data

Sep. 16, 1982 [DE] Fed. Rep. of Germany MR VIII/237

[52] U.S. Cl. D15/69

[58] Field of Search D15/69, 66, 68, 70; 112/63, 258-261

[56] References Cited

U.S. PATENT DOCUMENTS

D. 241,076	8/1976	Genaro	D15/69
D. 247,496	3/1978	Genaro et al.	D15/69
D. 250,649	12/1978	Hirano	D15/70
D. 265,737	8/1982	Kuroki	D15/70
3,570,431	3/1971	Fresard	112/63 X

Primary Examiner—Bernard Ansher
Assistant Examiner—Linda Titolo
Attorney, Agent, or Firm—McGlew and Tuttle

[57] CLAIM

The ornamental design for a sewing machine, as shown and described.

DESCRIPTION

FIG. 1 is a front left side perspective view of a sewing machine, showing my new design;
 FIG. 2 is a front left side perspective view thereof with the work support member removed for ease of illustration;
 FIG. 3 is a rear right side perspective view thereof;
 FIG. 4 is a front left side perspective view thereof including the work support member and showing the handle in upright position;
 FIG. 5 is a rear right side perspective view thereof;
 FIG. 6 is a front perspective view thereof;
 FIG. 7 is a rear perspective view thereof;
 FIG. 8 is a front perspective view thereof with the work support member removed for ease of illustration;
 FIG. 9 is a rear perspective view thereof;
 FIG. 10 is a left side perspective view thereof including the work support member;
 FIG. 11 is a right side perspective view thereof;
 FIG. 12 is a left side perspective view thereof with the work support member removed for ease of illustration;
 FIG. 13 is a right side perspective view thereof;
 FIG. 14 is a top perspective view thereof including the work support member;
 FIG. 15 is a top perspective view thereof with the handle in an alternate position; and
 FIG. 16 is a bottom perspective view thereof.
 The stippled shading on the drawing represents color contrast.

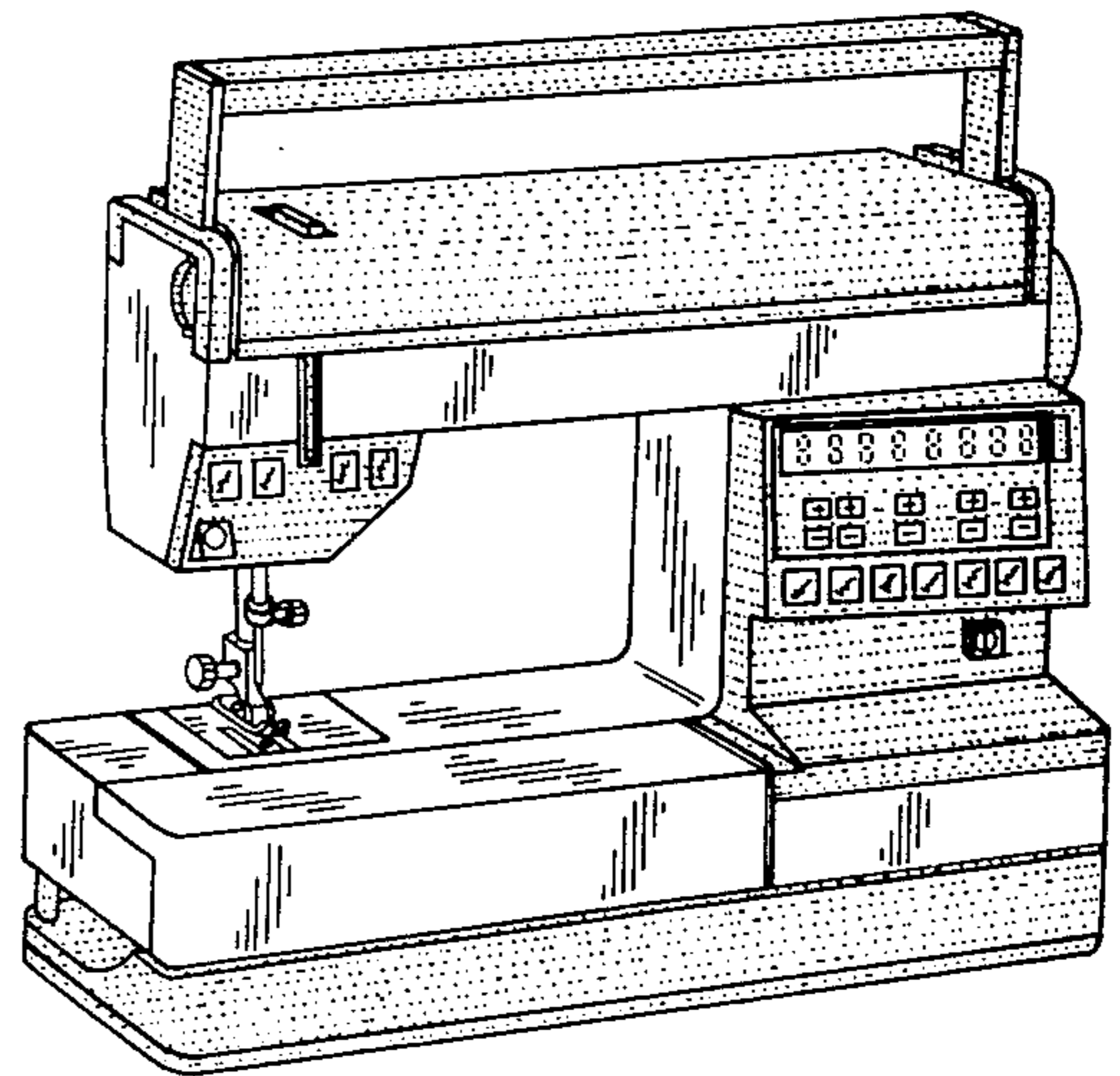
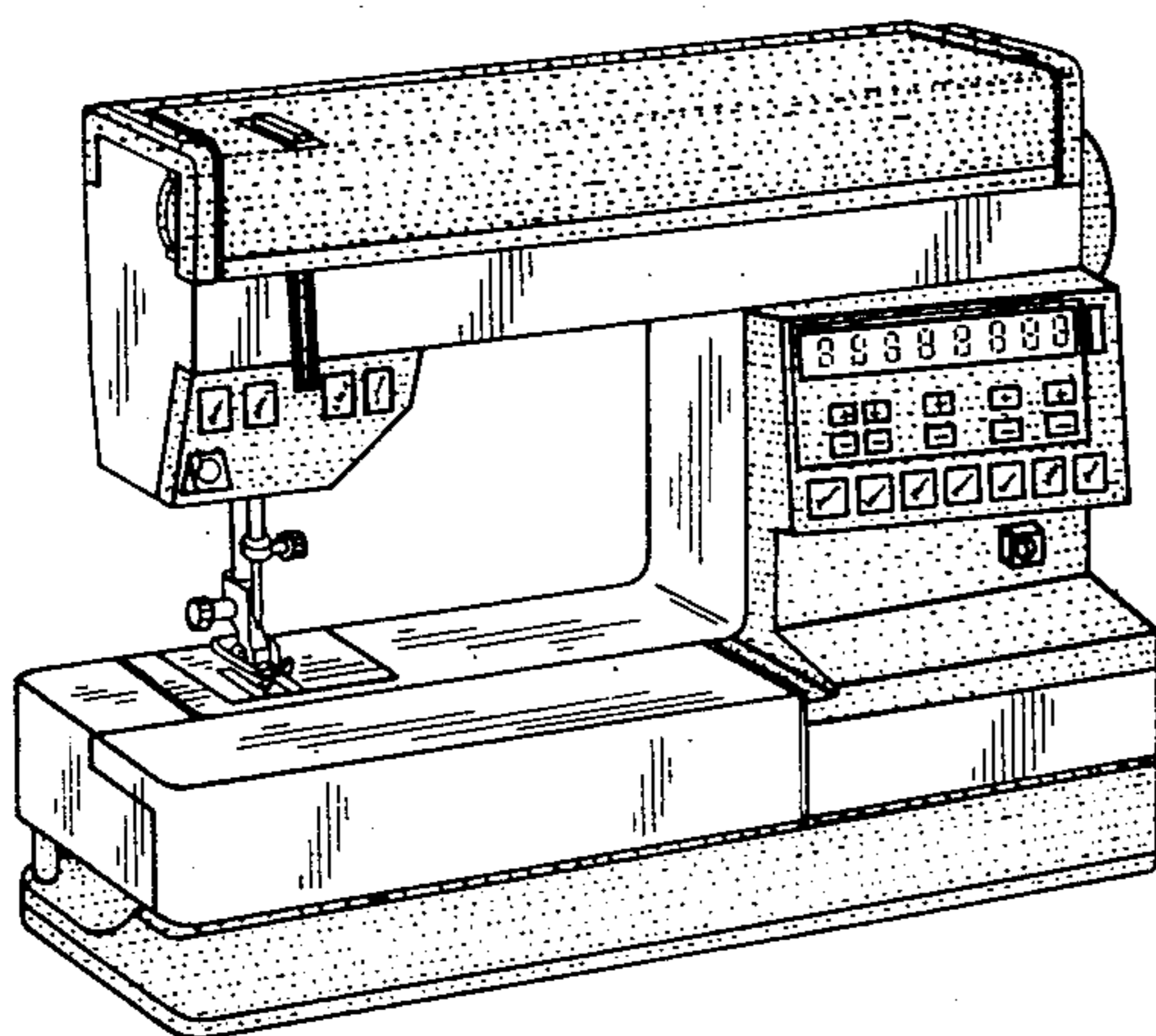

Fig. 1

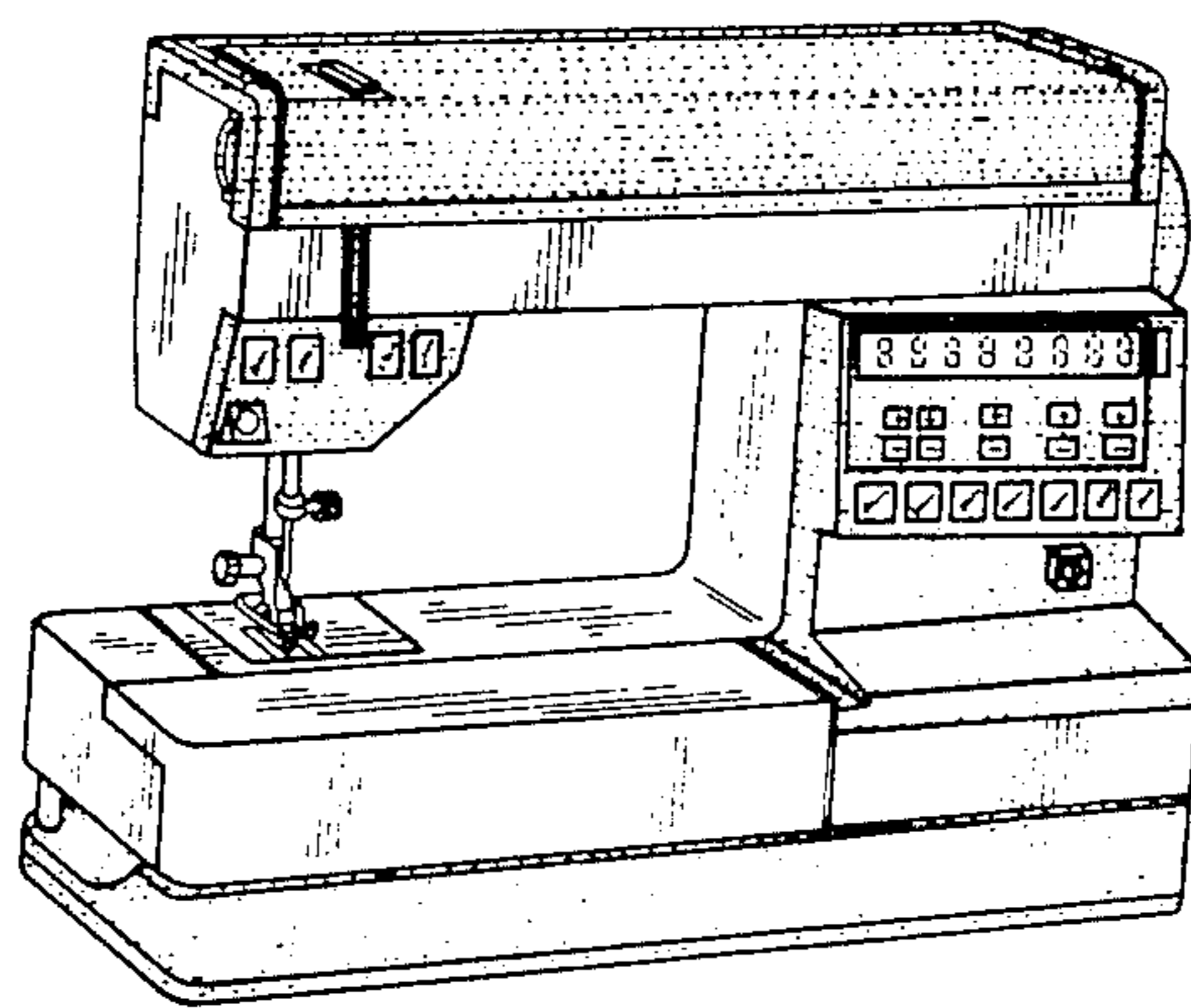

Fig. 2

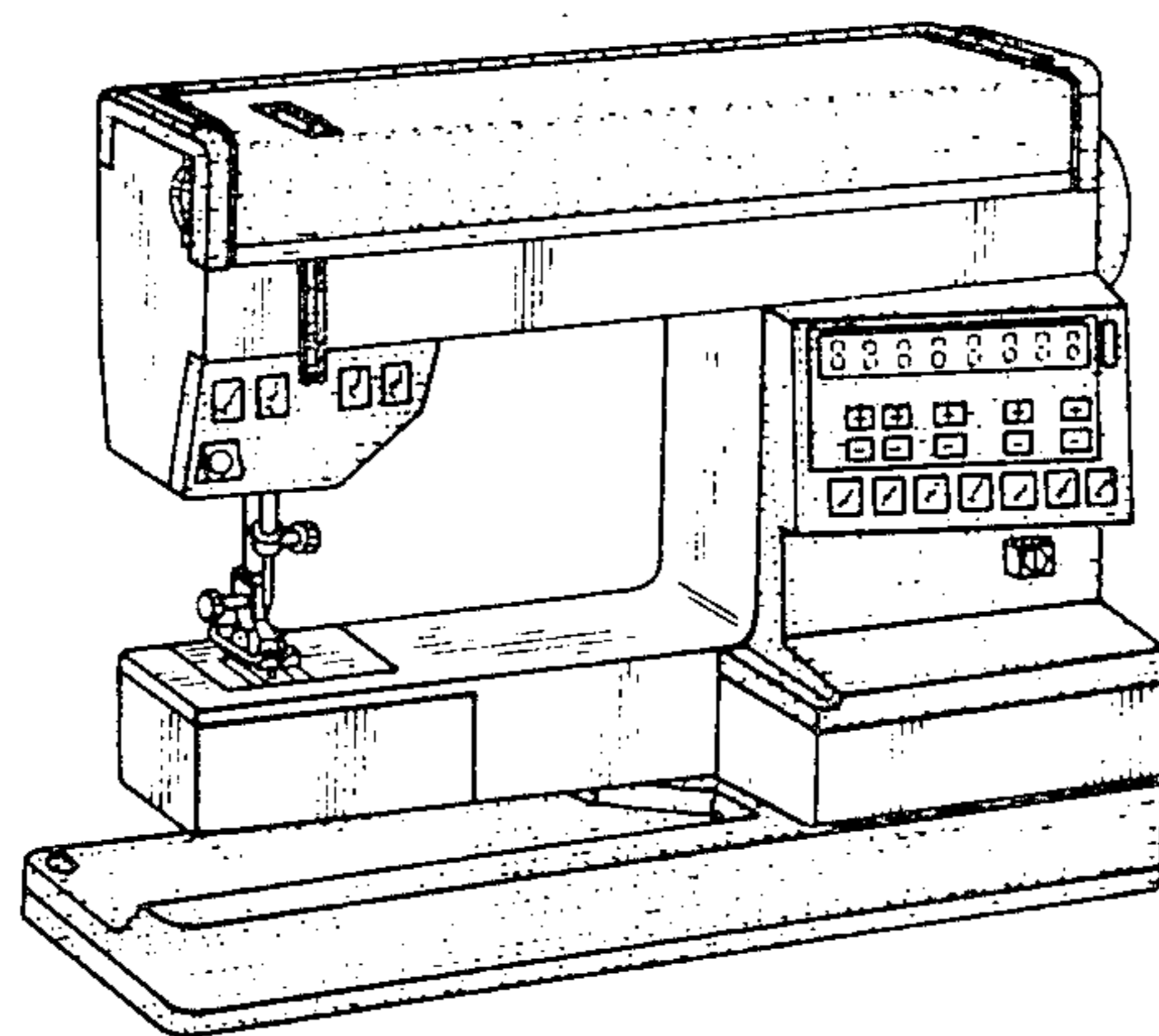

Fig. 3

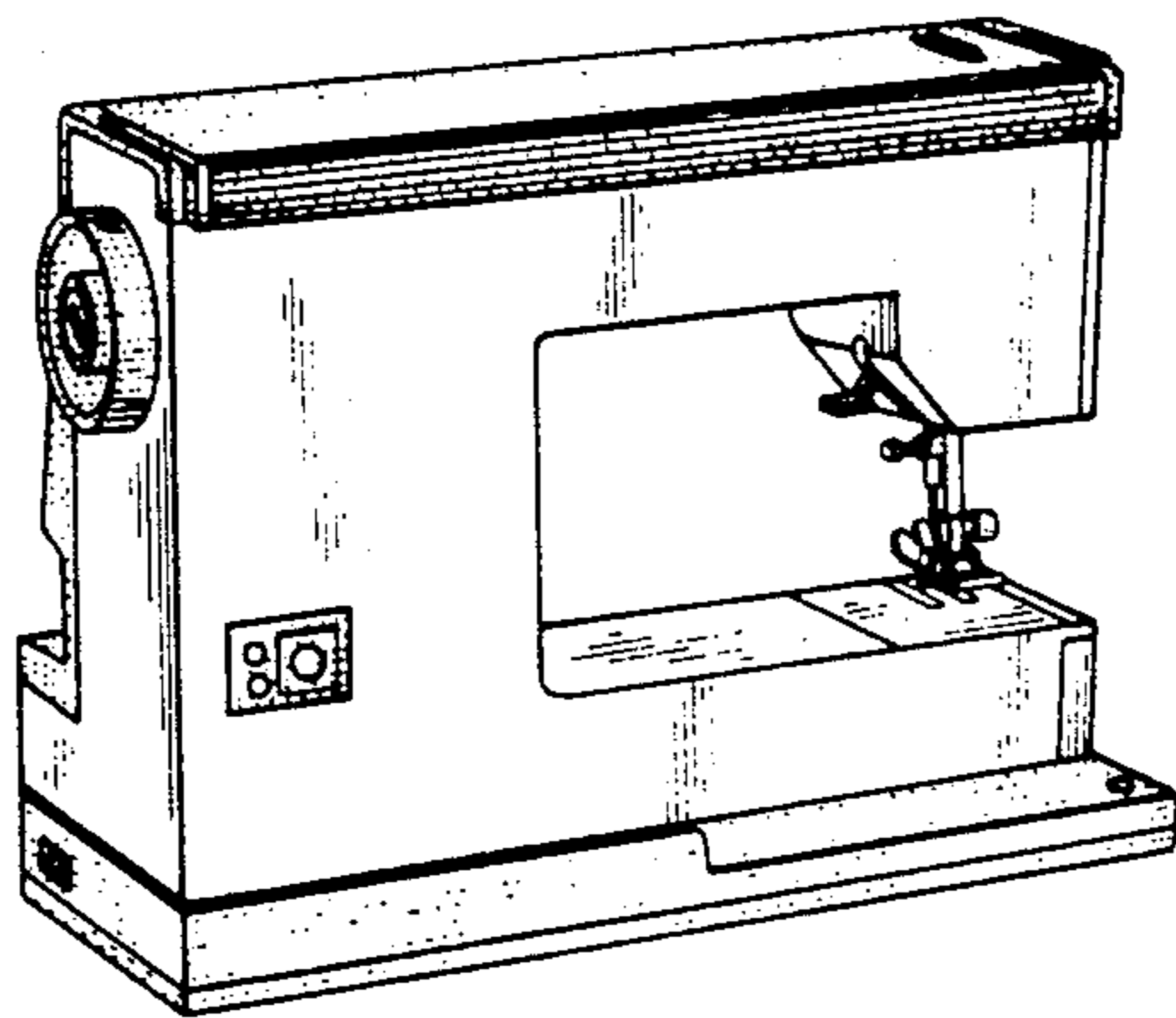

Fig. 4

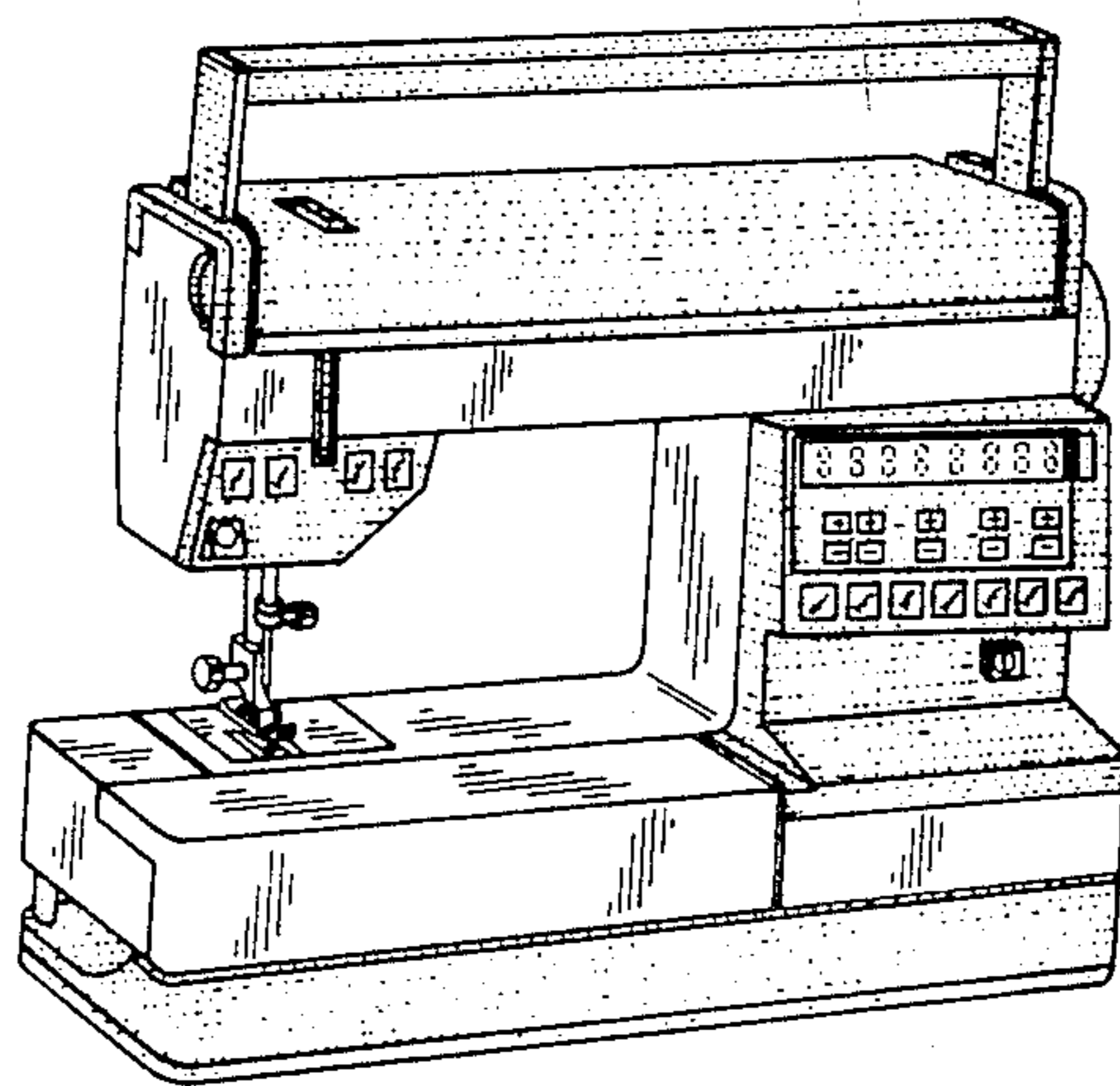

Fig. 5

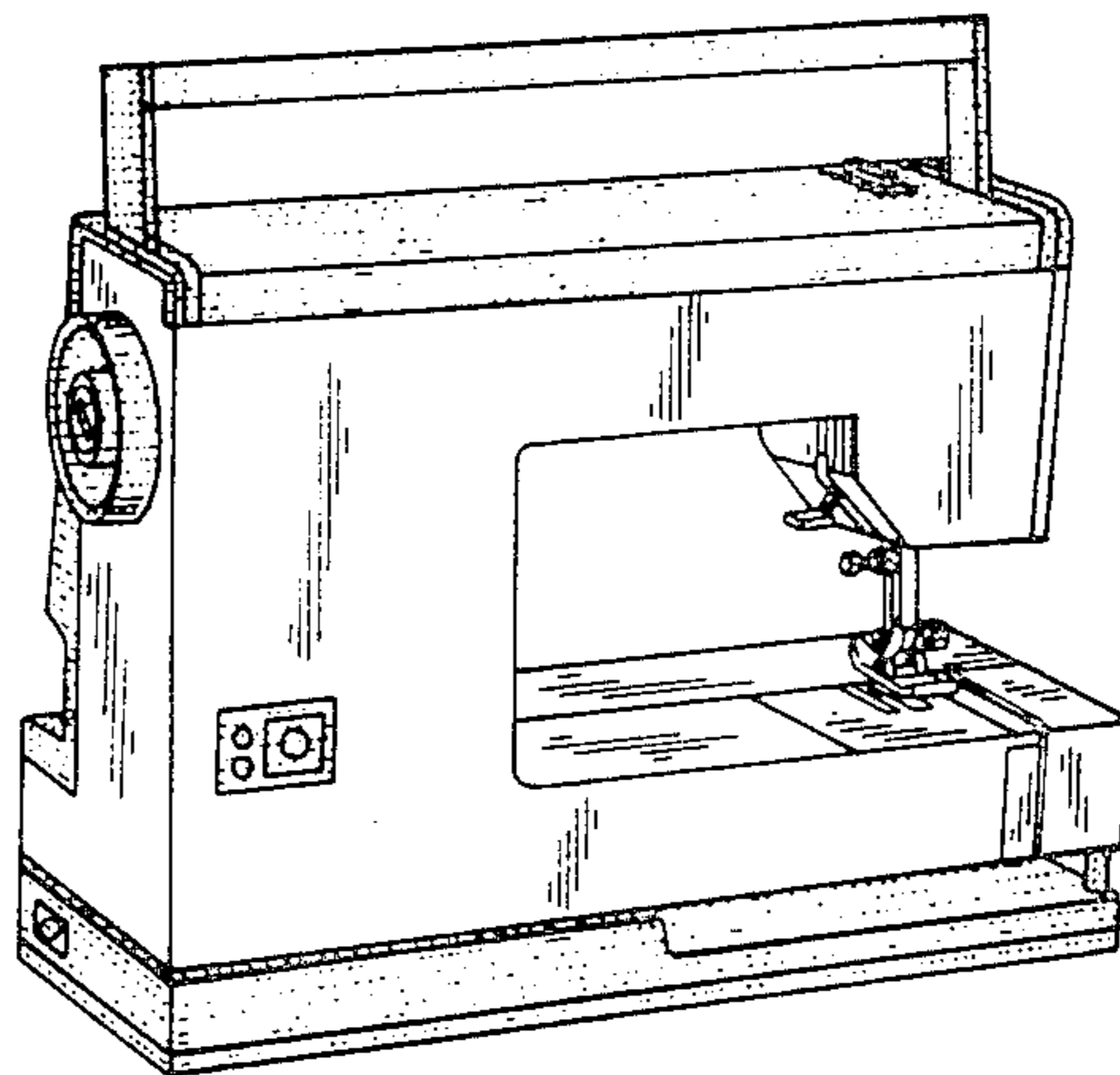

Fig. 6

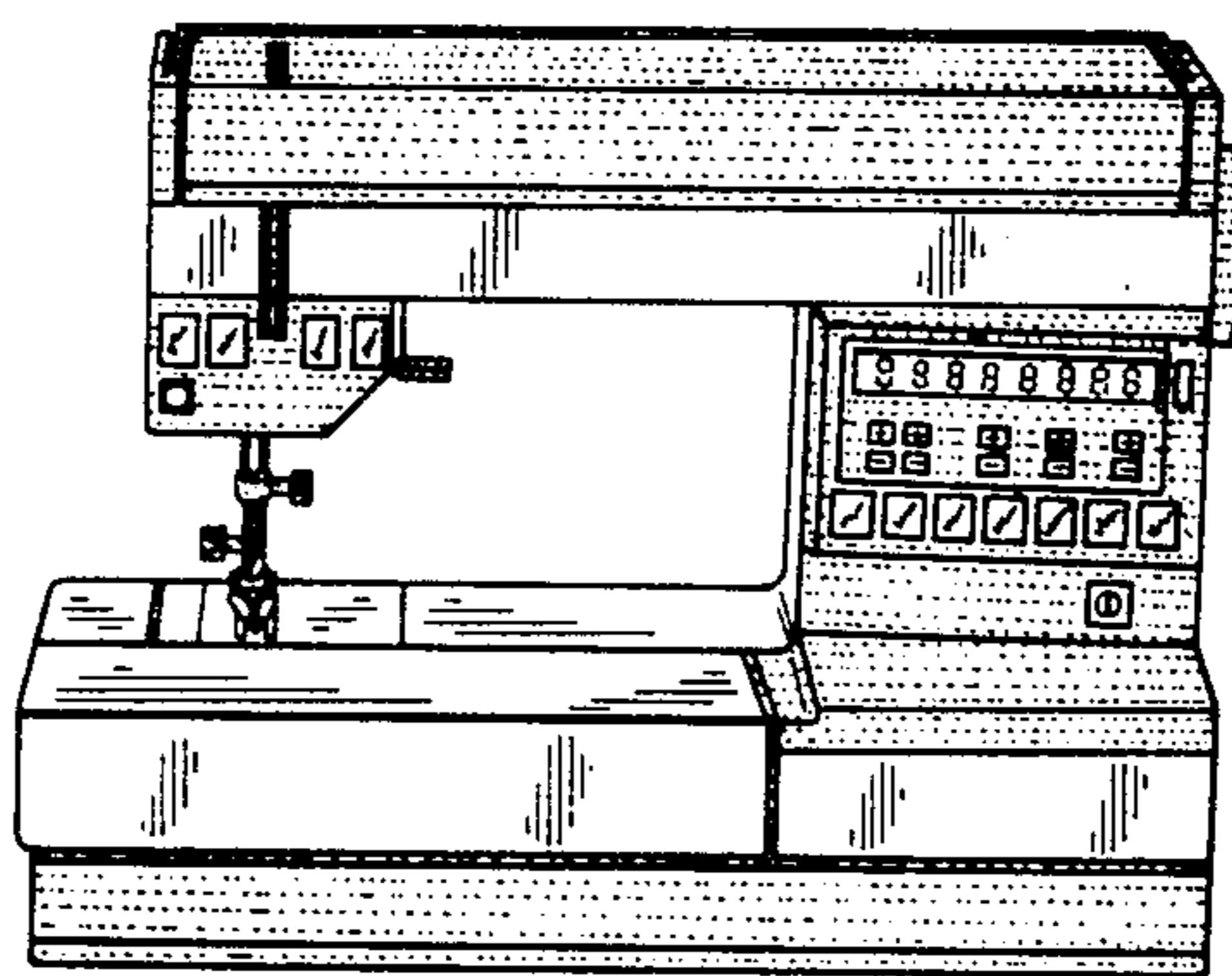

Fig. 7

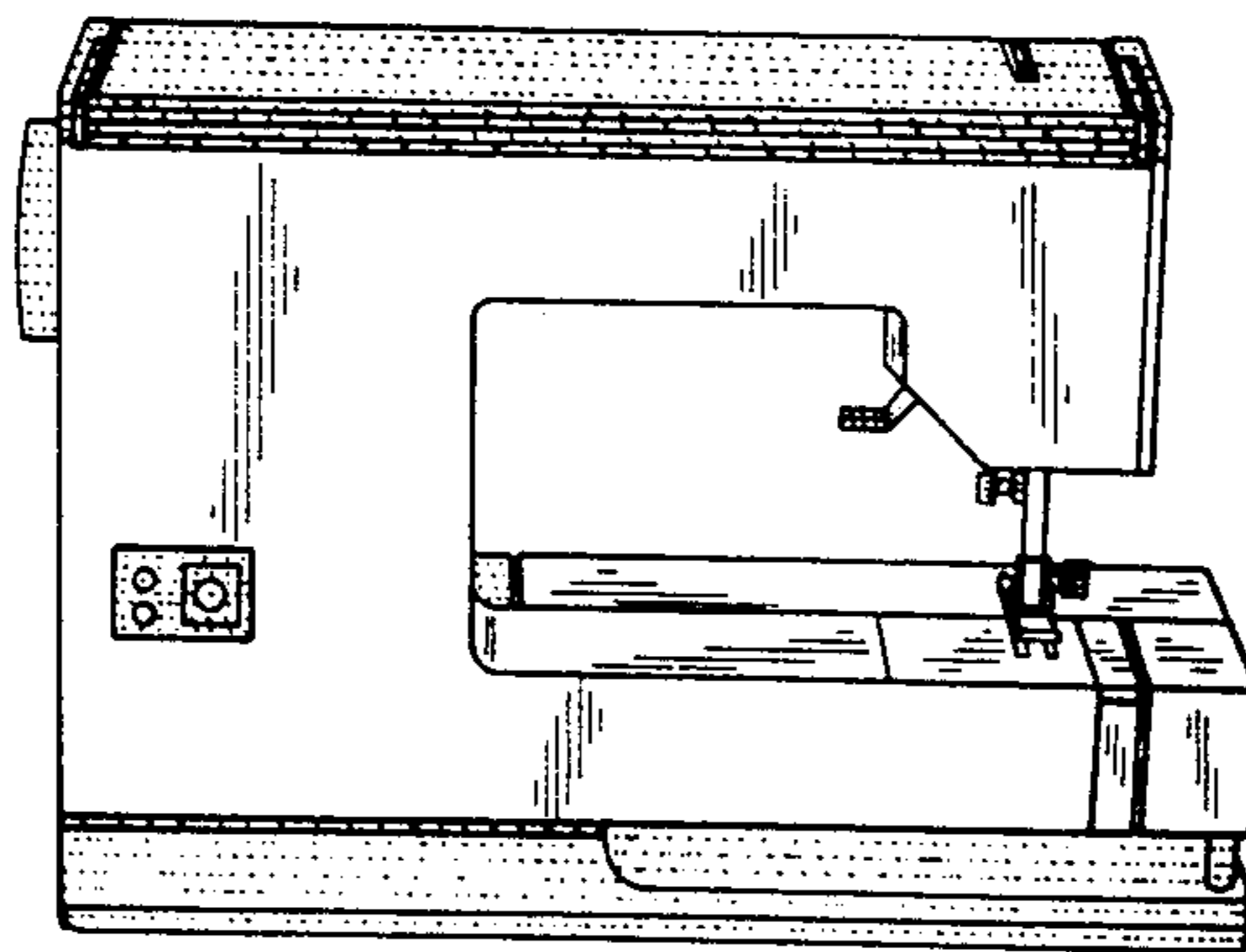

Fig. 8

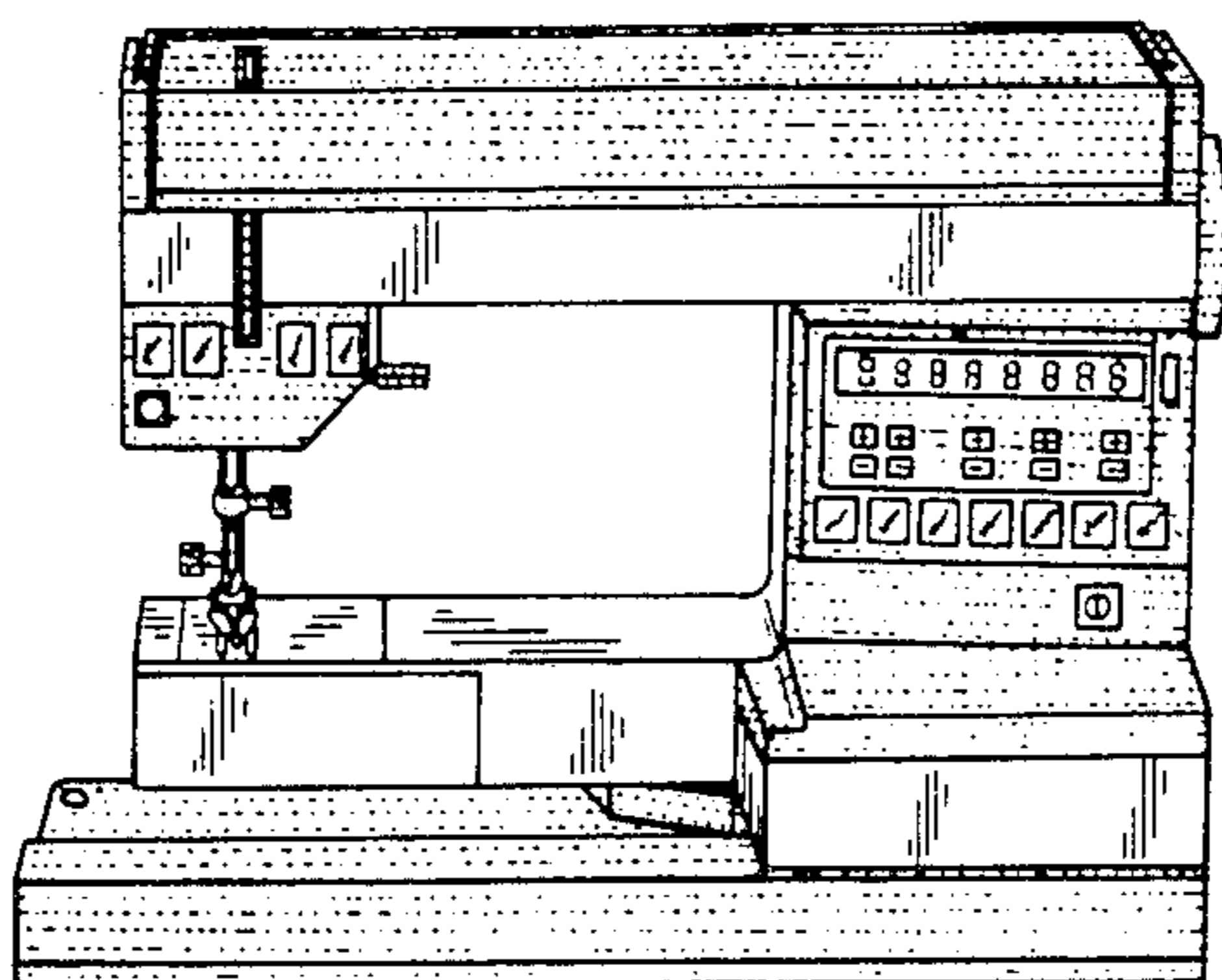

Fig. 9

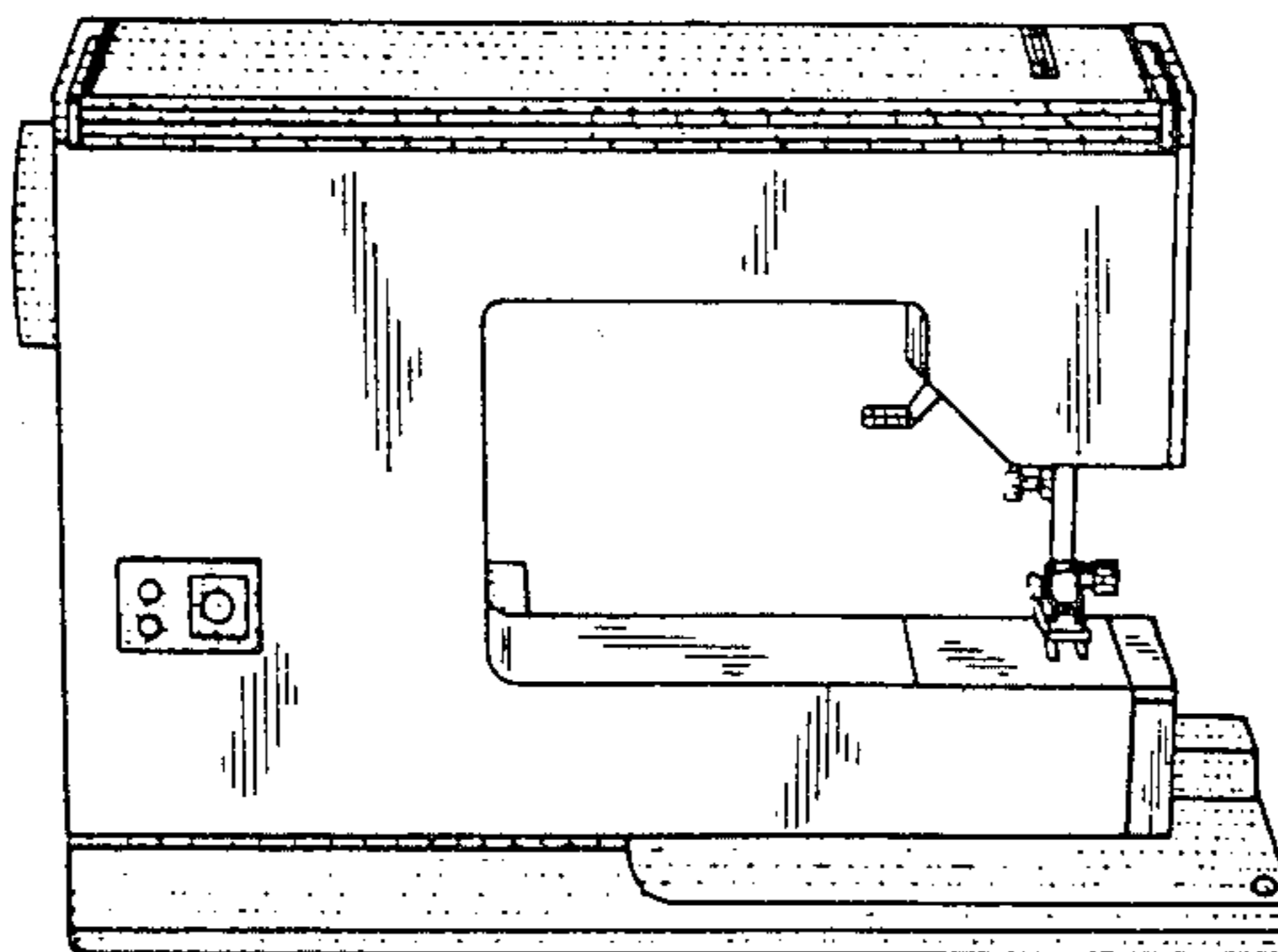

Fig. 10

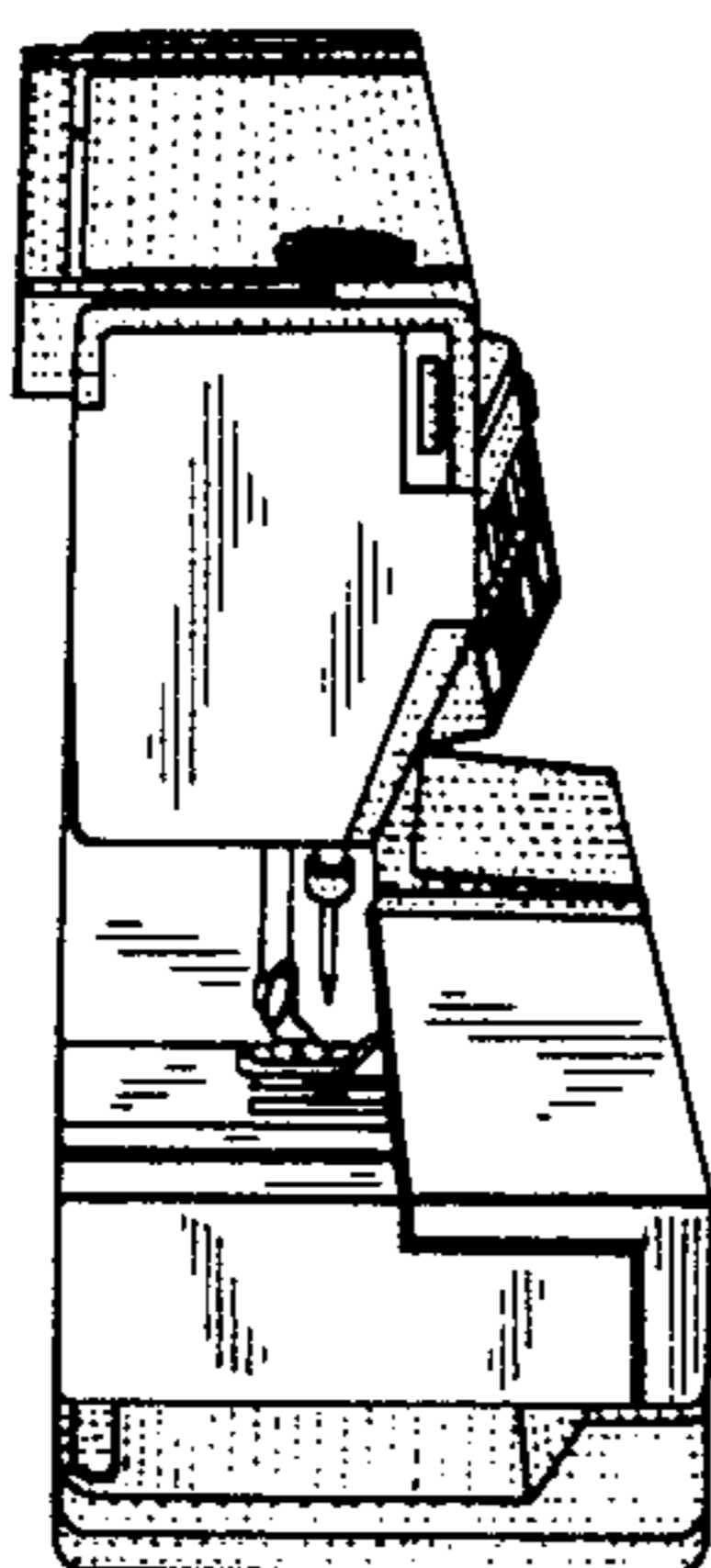

Fig. 11

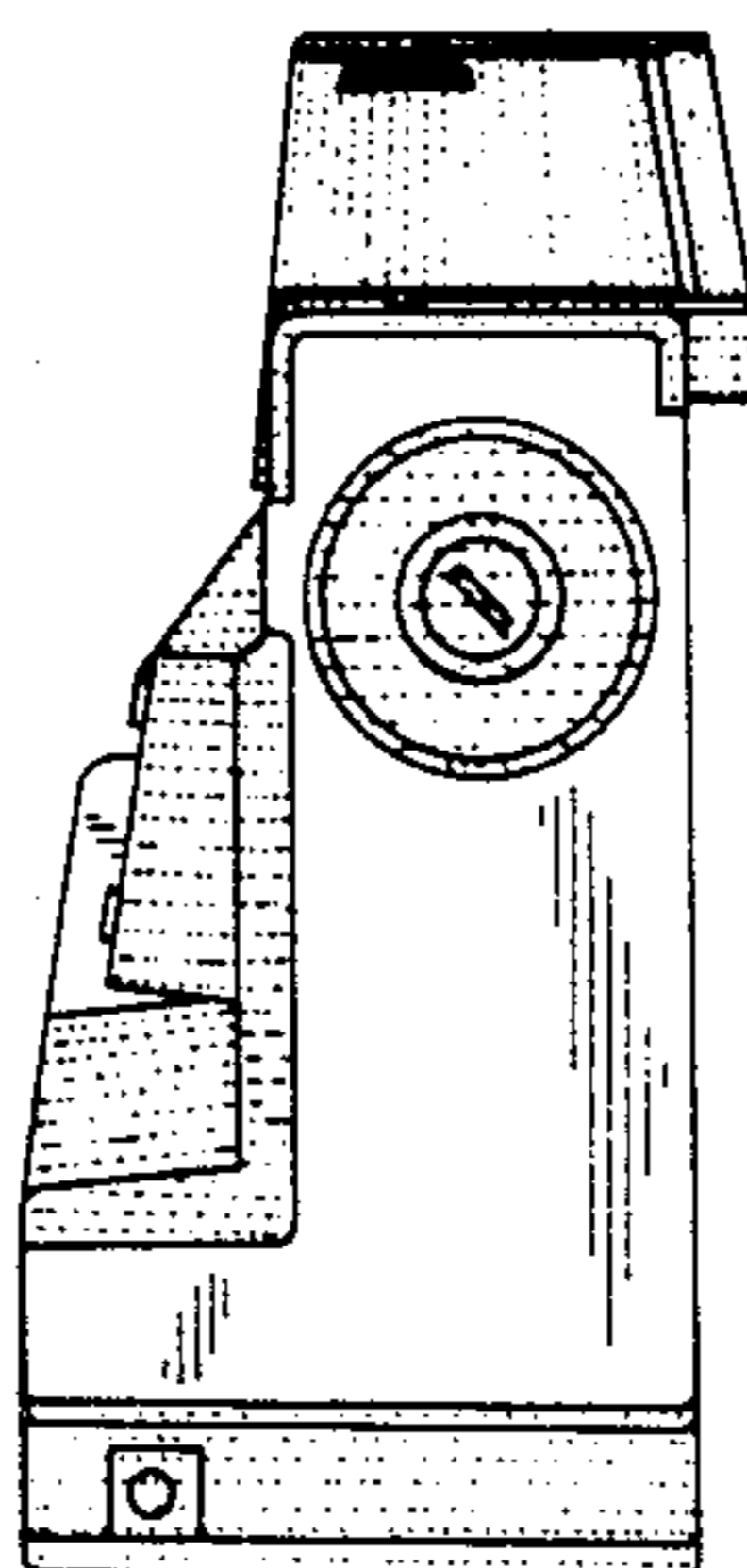

Fig. 12

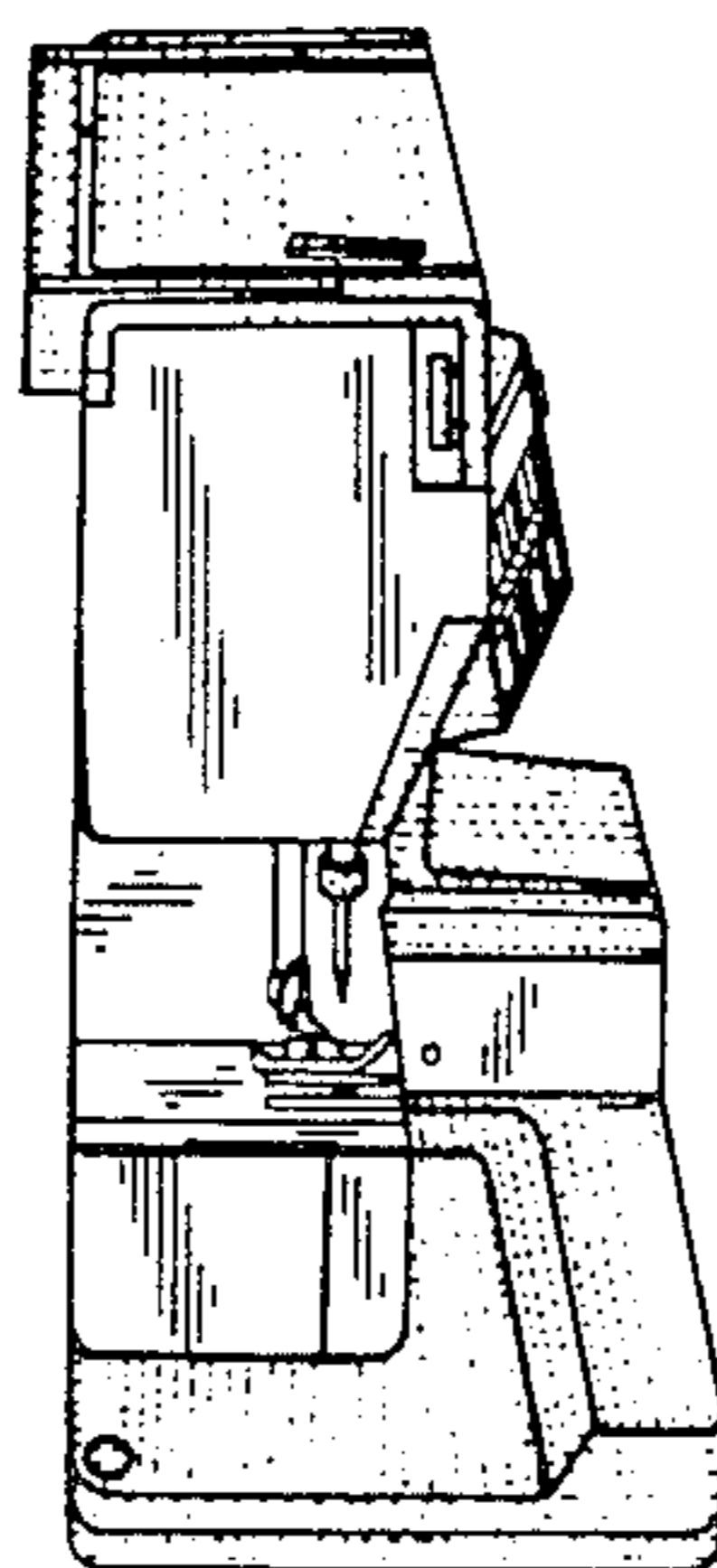

Fig. 13

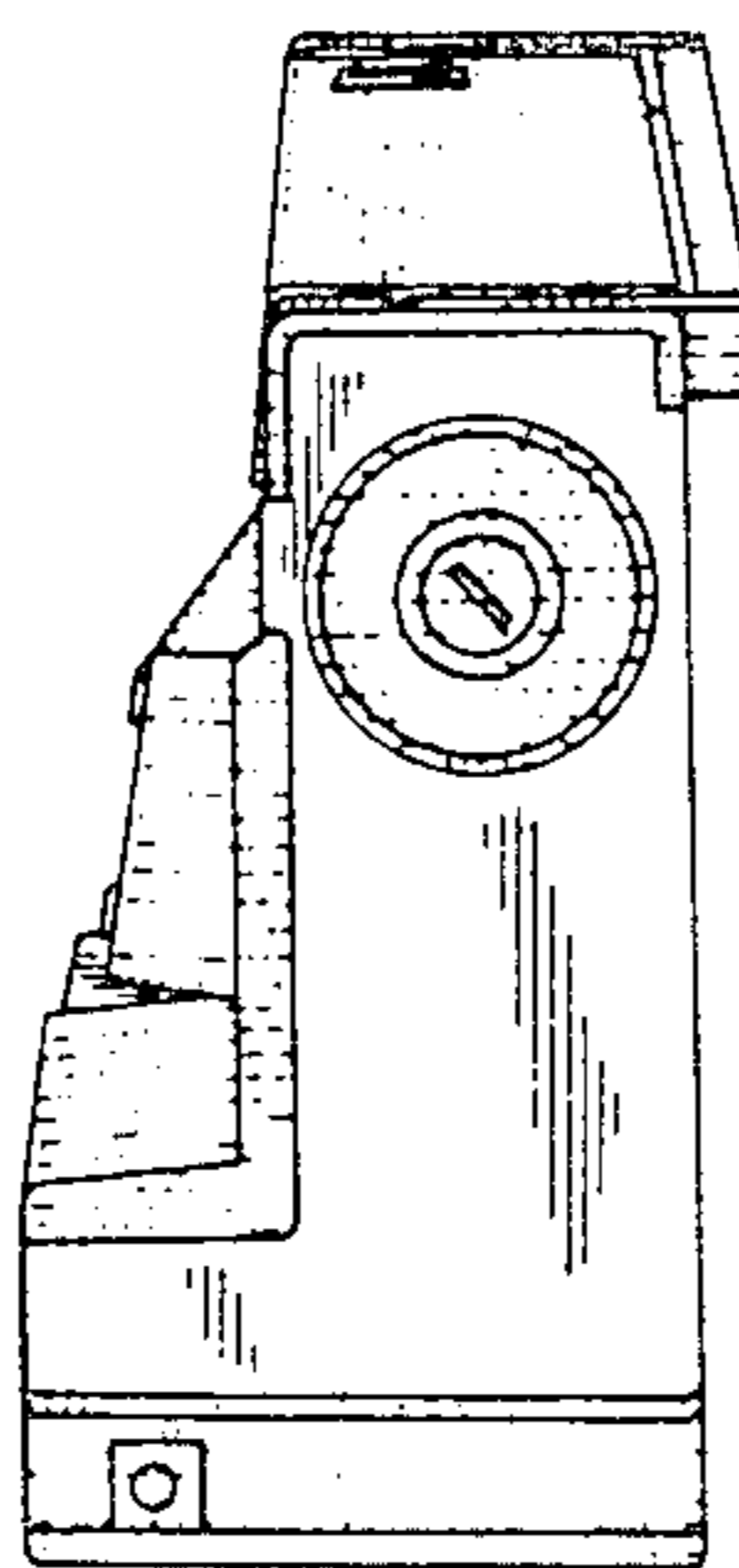

Fig. 14

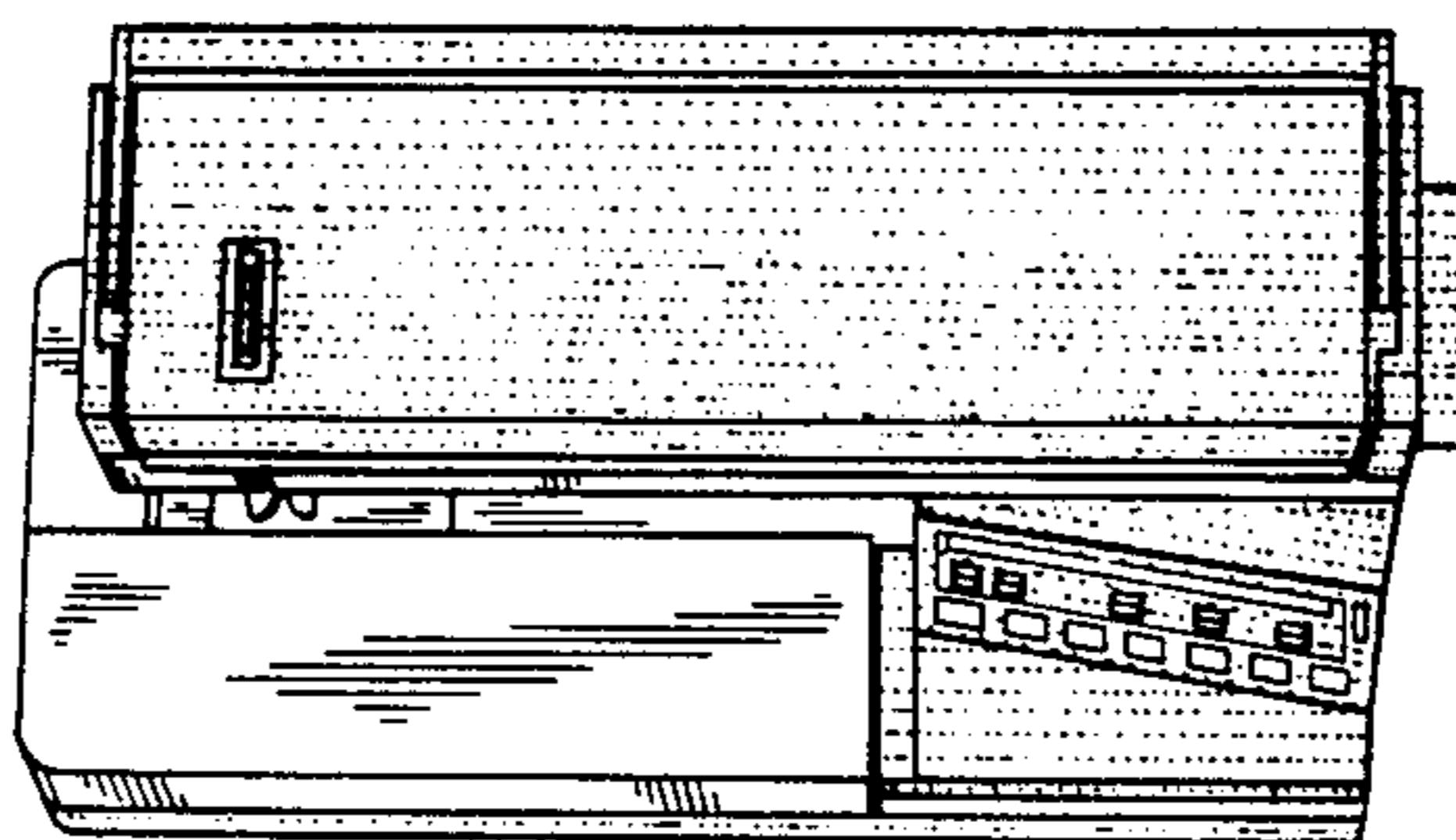

Fig. 15

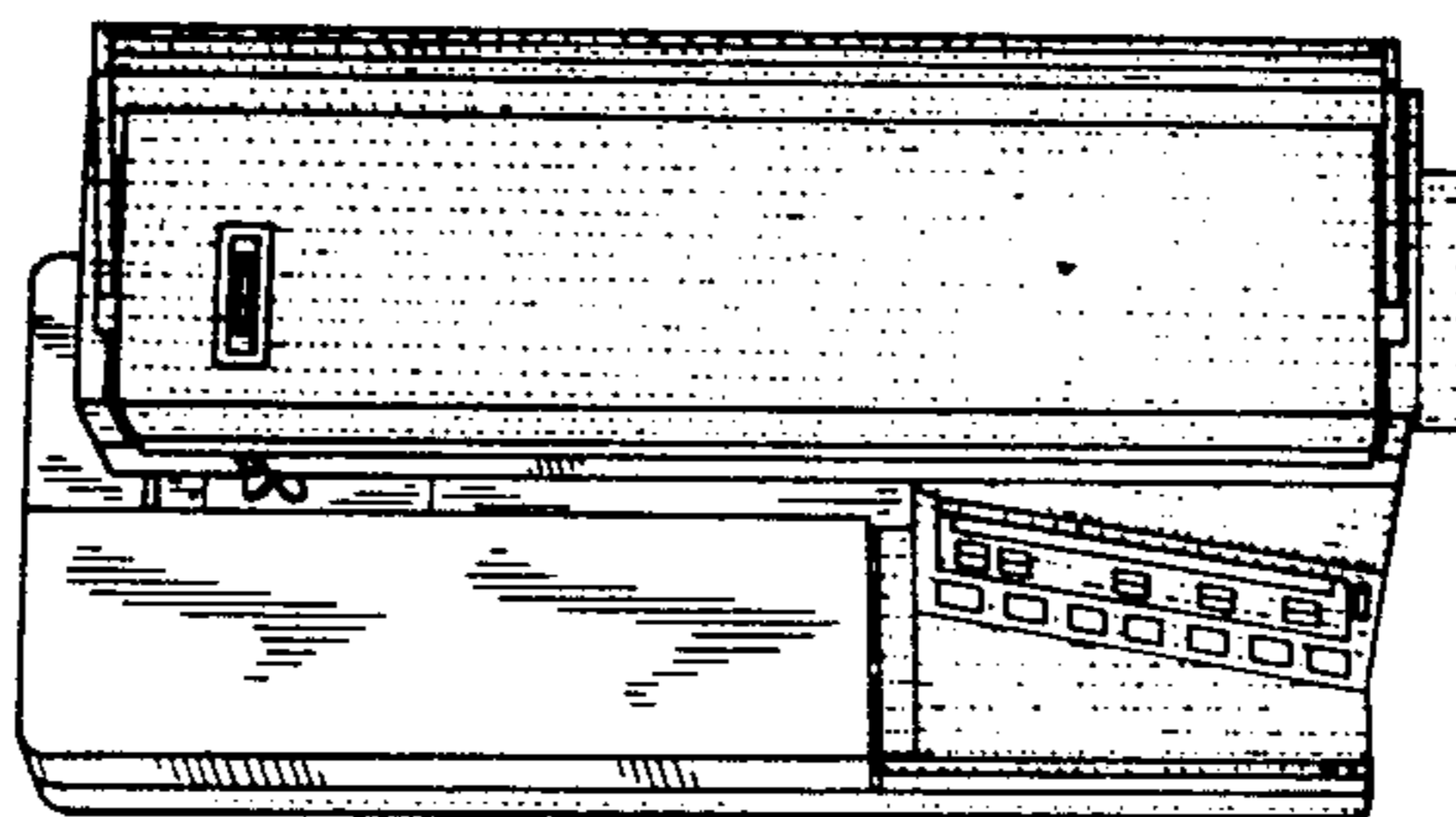

Fig. 16

