

[54] **MOTORCYCLE**

[75] **Inventors:** Karl H. Abe, Steinebach/Woerthsee; Klaus V. Gevert, Munich, both of Fed. Rep. of Germany

[73] **Assignee:** Bayerische Motoren Werke A.G., Fed. Rep. of Germany

[\*\*] **Term:** 14 Years

[21] **Appl. No.:** 550,130

[22] **Filed:** Nov. 9, 1983

[30] **Foreign Application Priority Data**

May 9, 1983 [DE] Fed. Rep. of Germany ..... MR NO. 13415

[52] **U.S. Cl.** ..... D12/110

[58] **Field of Search** ..... D12/110; 180/219, 221, 180/229, 231

[56] **References Cited**  
**PUBLICATIONS**

Cycle World, 4/82, p. 37, Honda CX500 Motorcycle, bottom of page.  
Cycle World, 6/82, pp. 28 & 29, Yamaha Seca 650.  
Road & Track, 9/81, p. 102, Front Radiator Grille Of BMW 323i, top left side of page.

*Primary Examiner*—James M. Gandy  
*Attorney, Agent, or Firm*—Craig and Burns

[57] **CLAIM**

The ornamental design for a motorcycle, as shown.

**DESCRIPTION**

FIG. 1 is a perspective view of the motorcycle embodying our novel design from in front and toward the left; FIG. 2 is a perspective view from in front and toward the right thereof; FIG. 3 is a perspective view from the rear and toward the left thereof; FIG. 4 is a perspective view from the rear and toward the right thereof; FIG. 5 is a left side elevational view thereof; FIG. 6 is a right side elevational view thereof; FIG. 7 is a front elevational view thereof; FIG. 8 is a rear elevational view thereof; and FIG. 9 is a top plan view thereof.

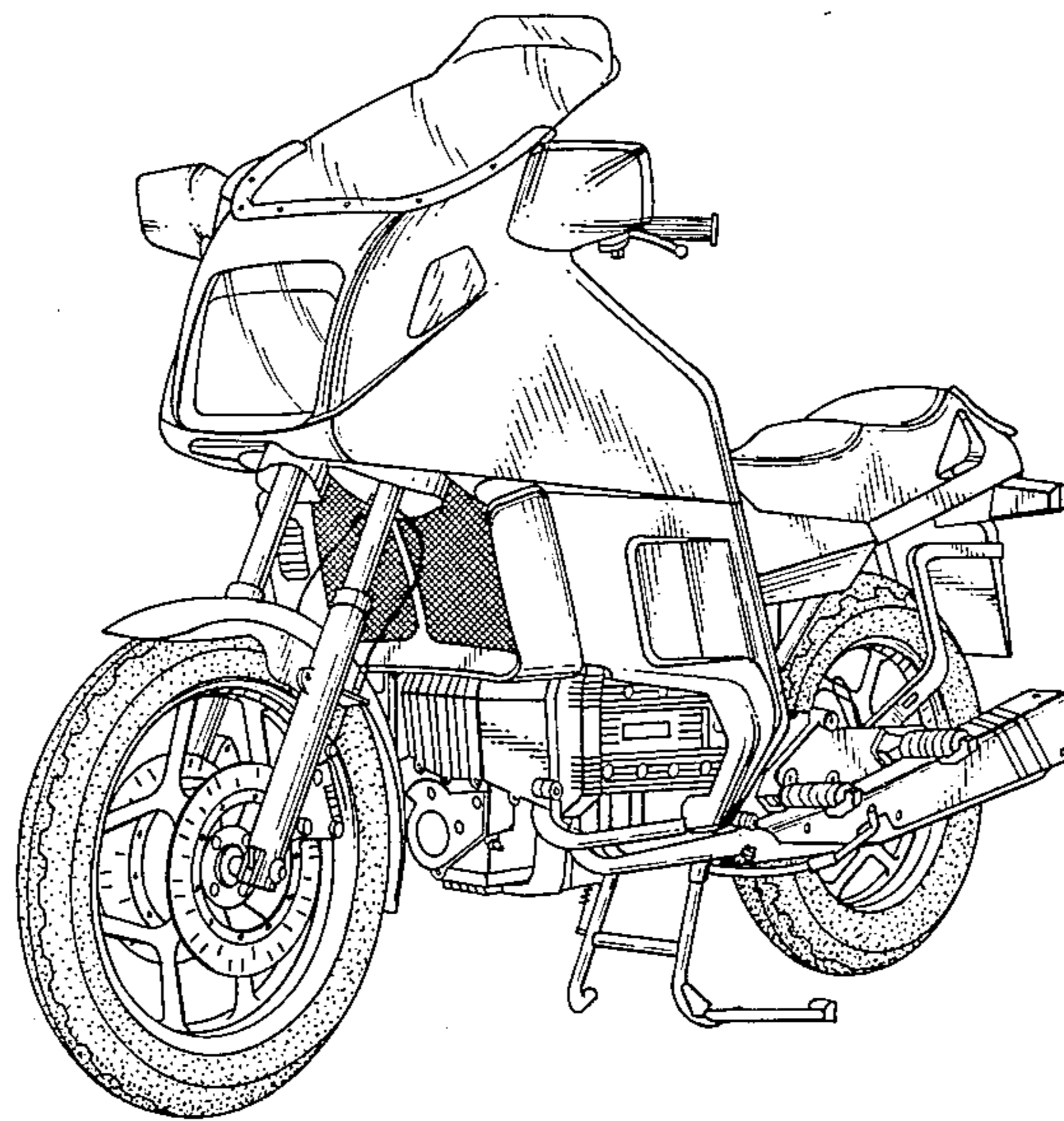

FIG. 1.

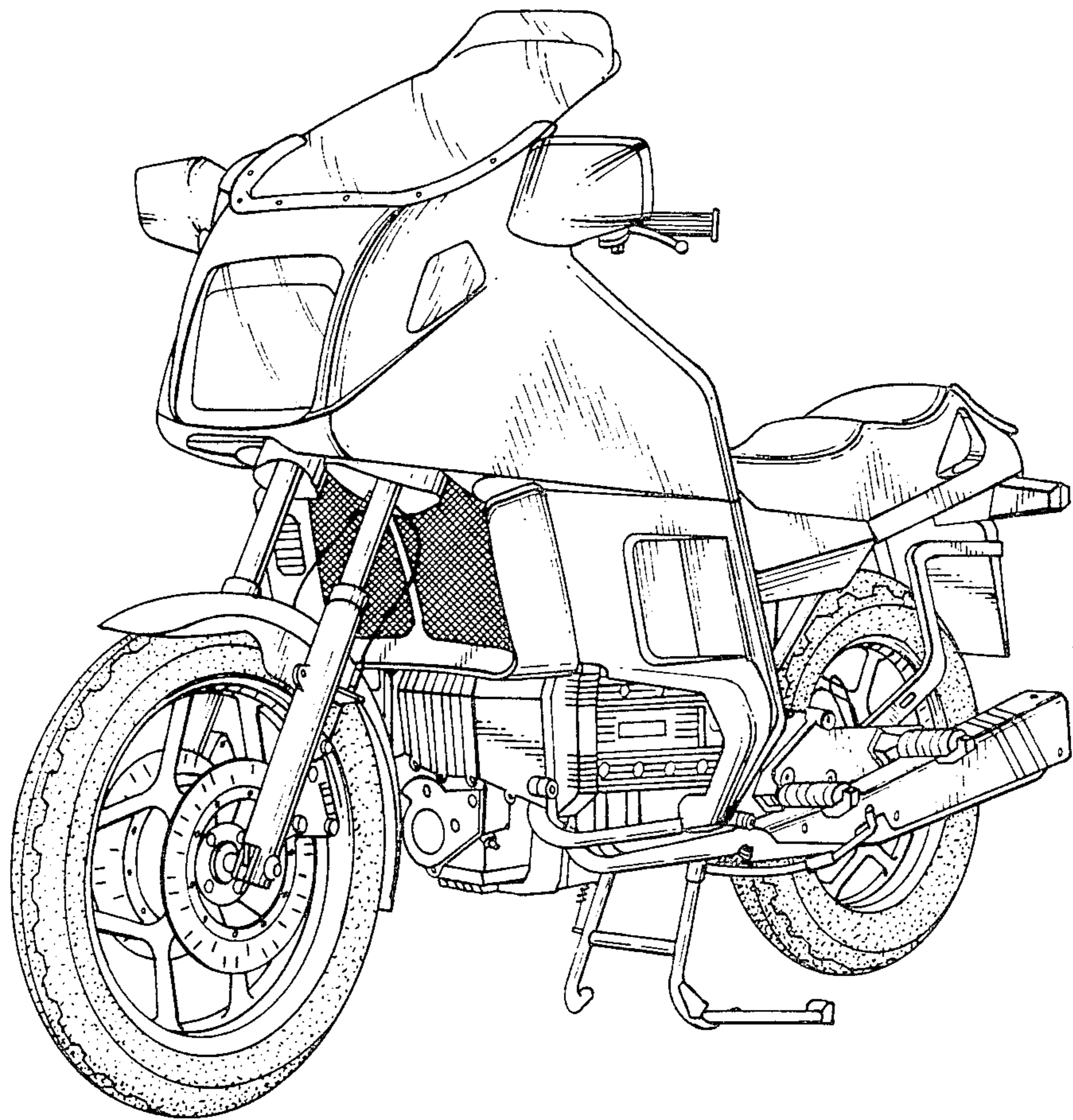

FIG. 2.

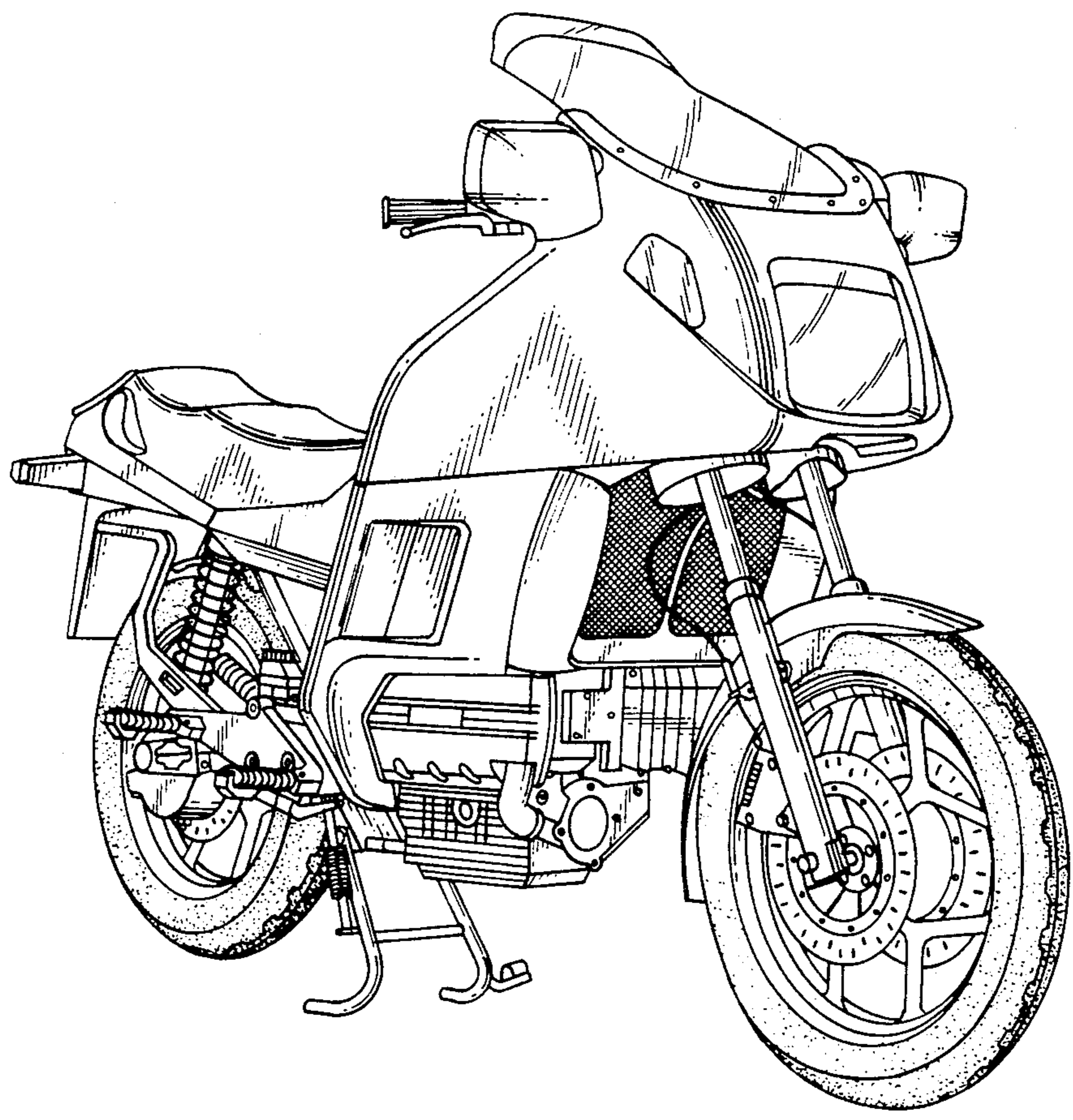



FIG. 3.

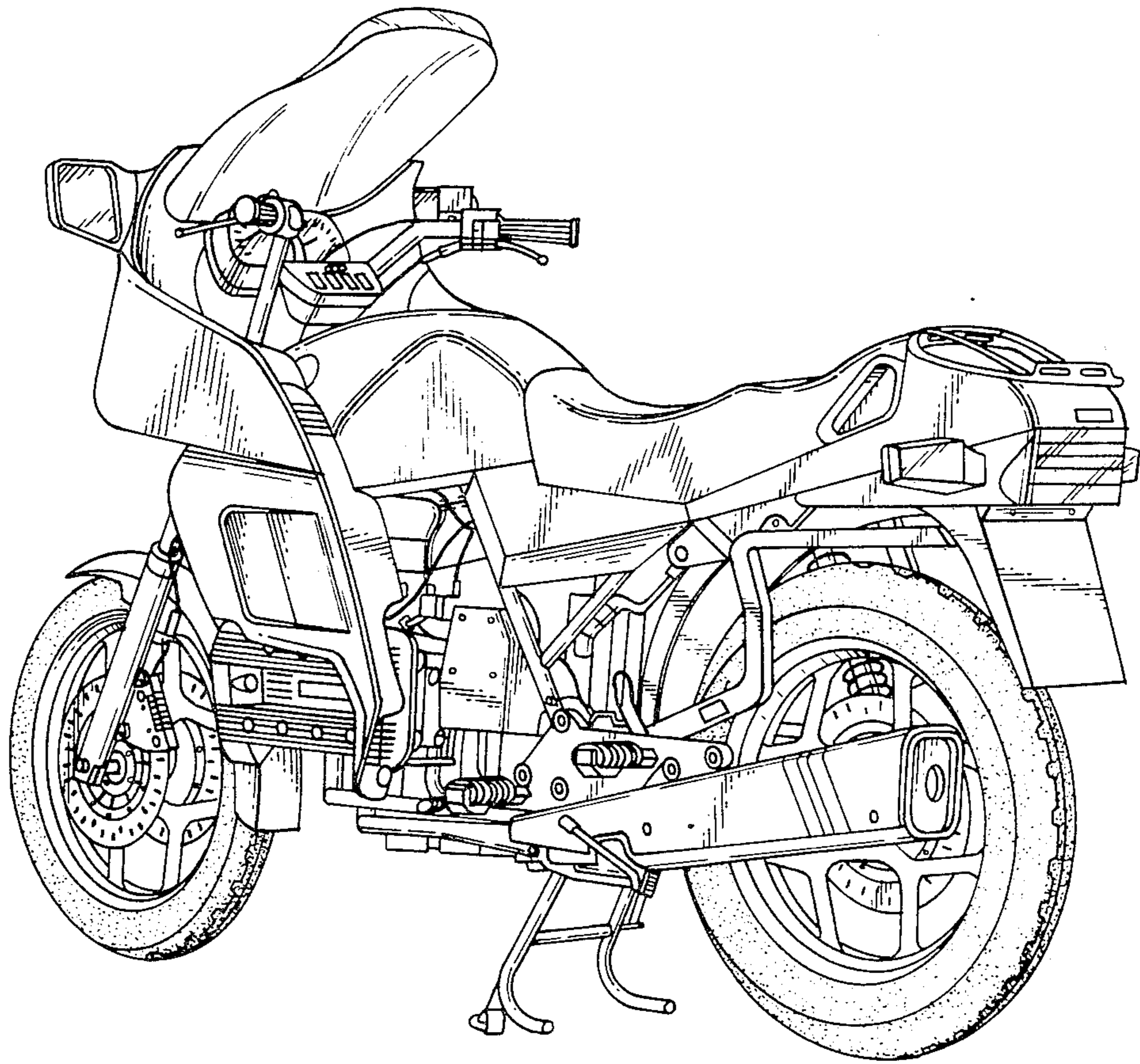

FIG. 4.

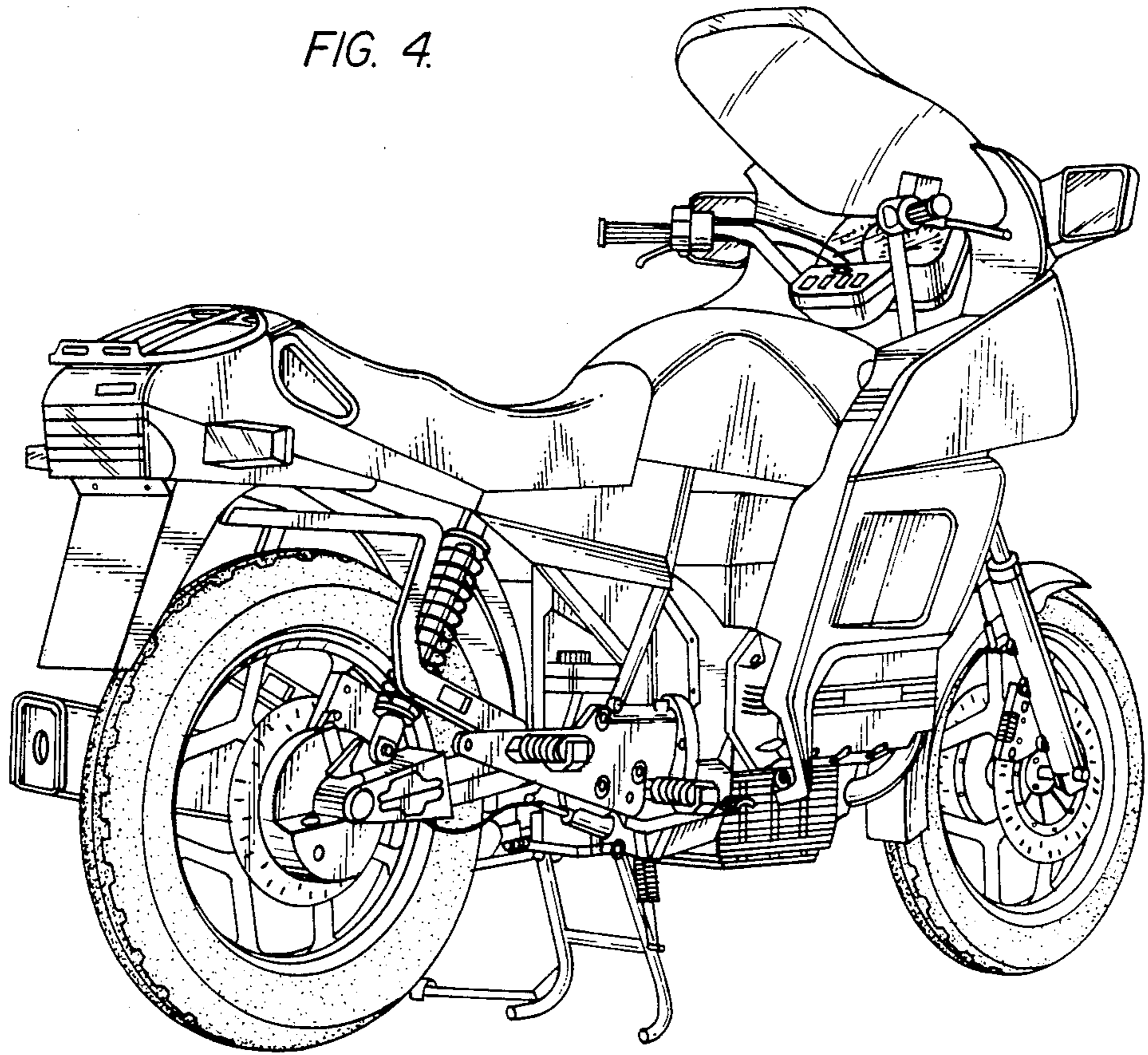
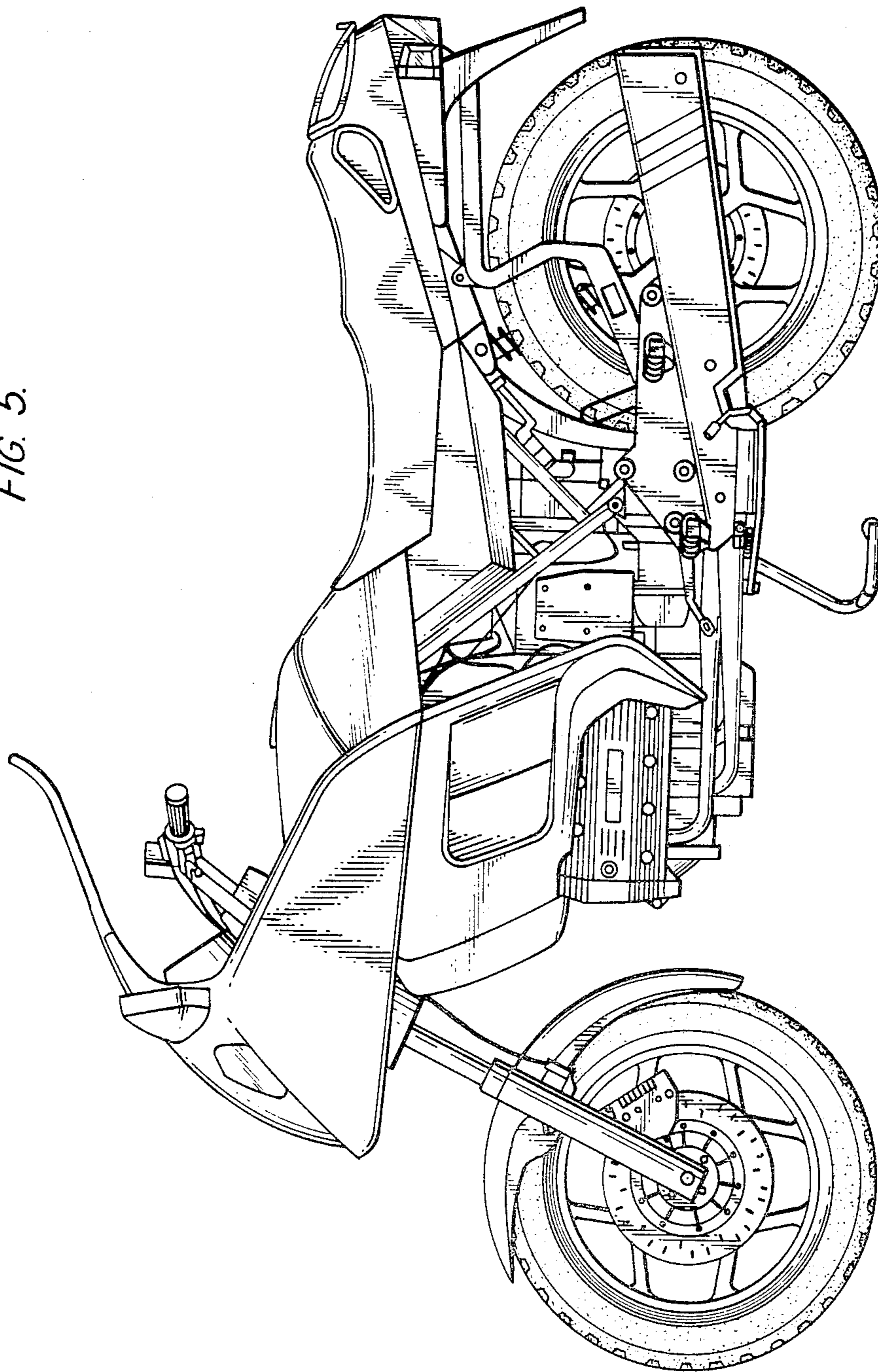

FIG. 5.





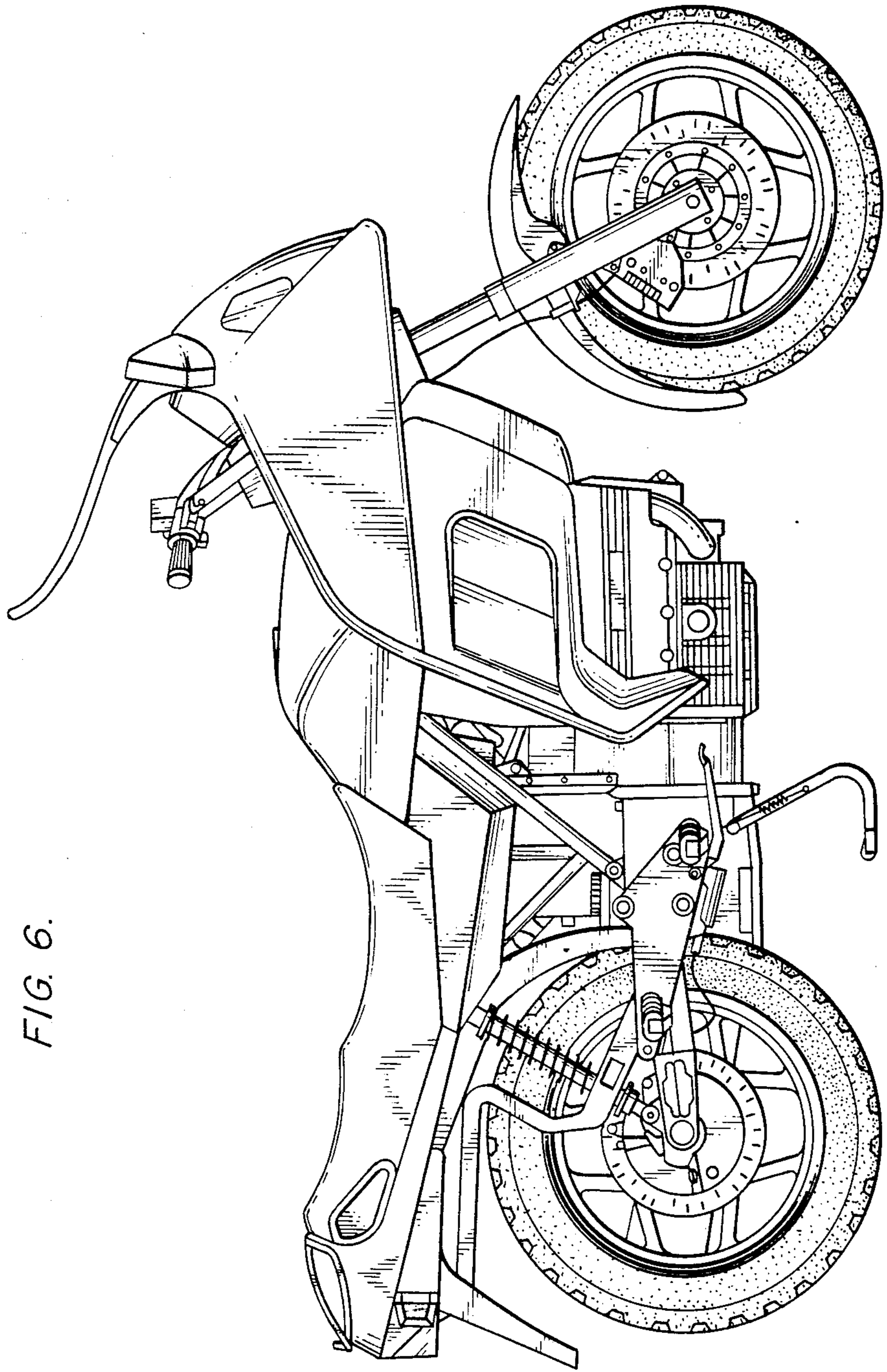

FIG. 6.

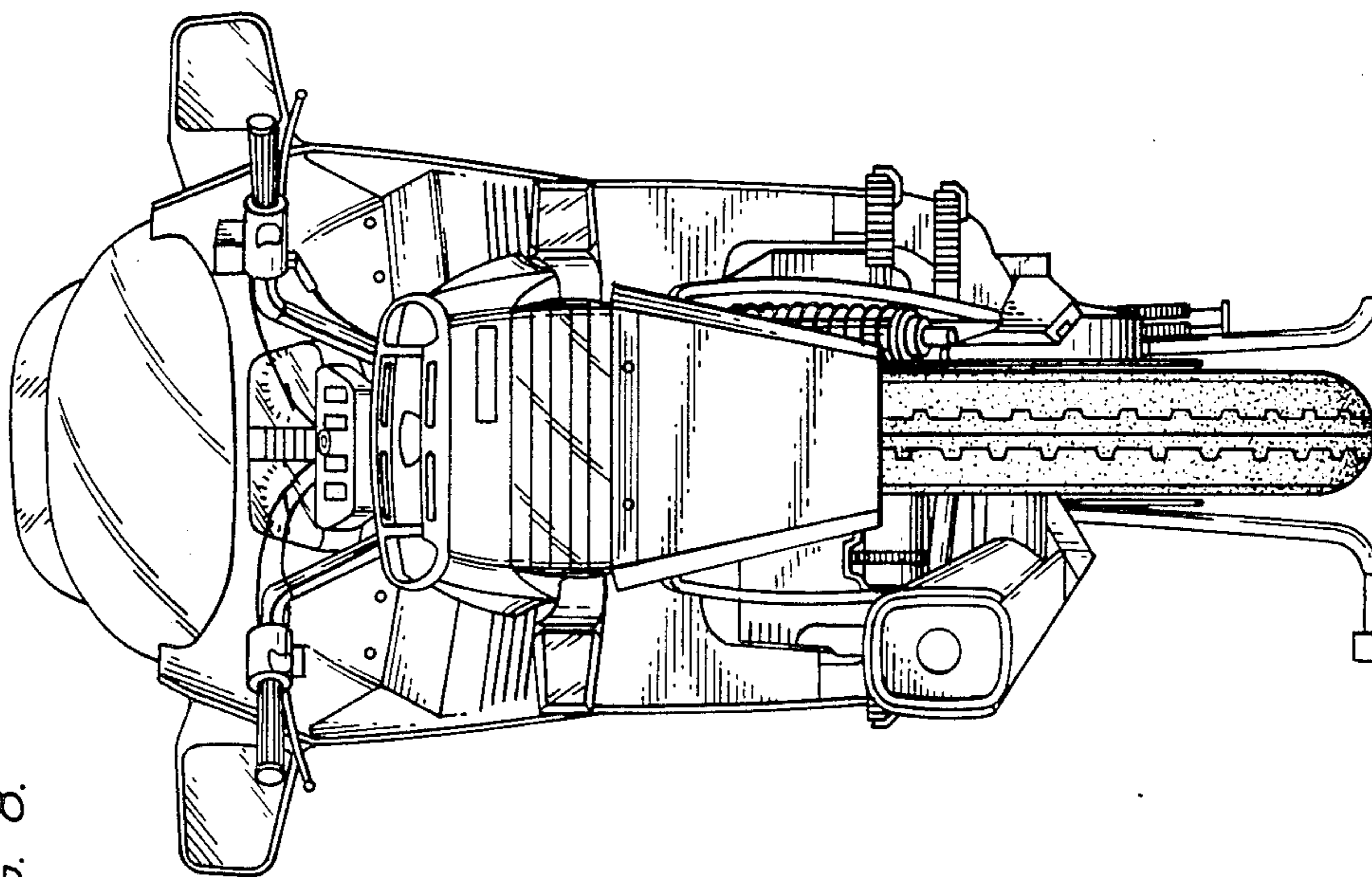

FIG. 8.

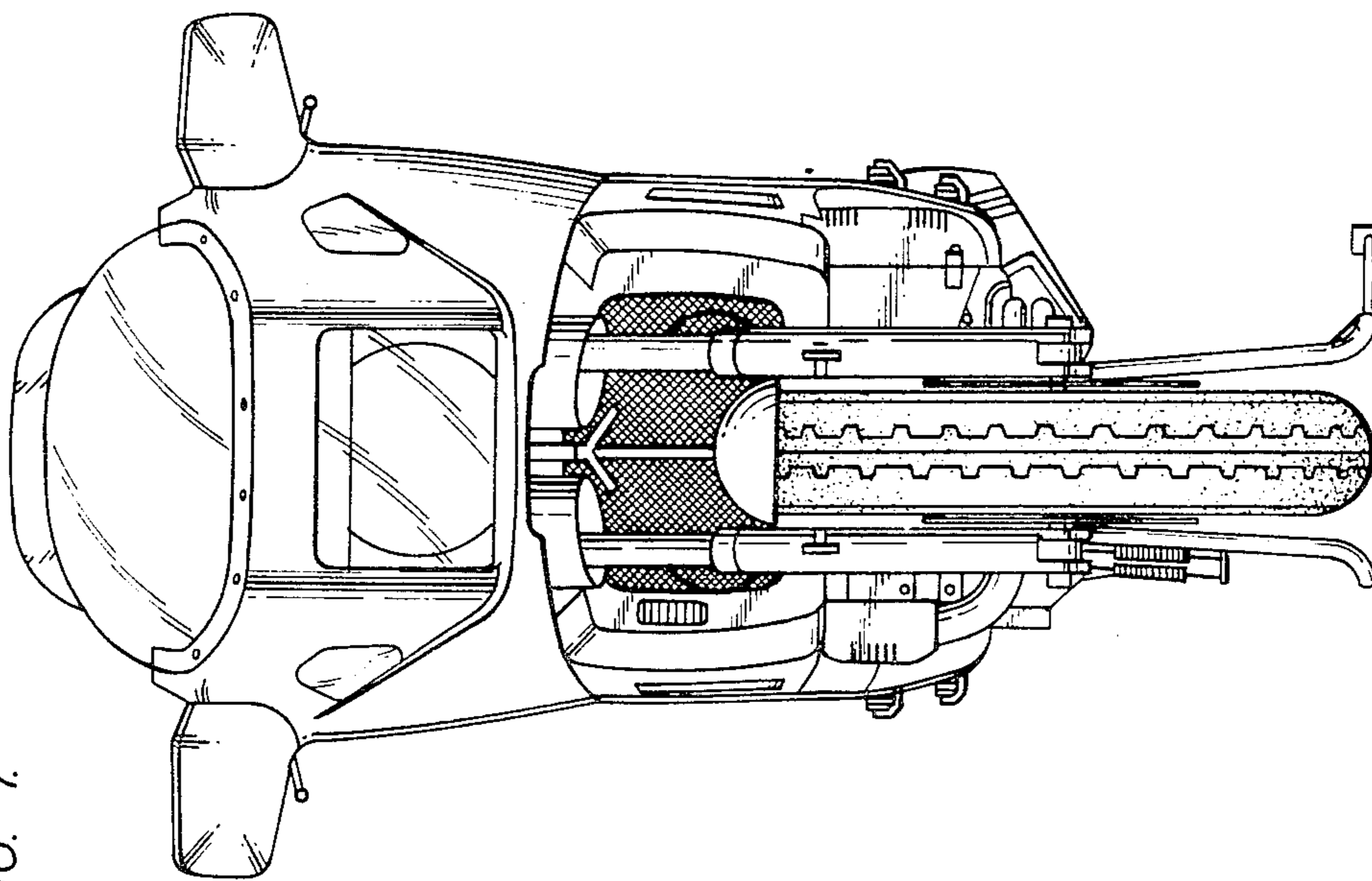

FIG. 7.



FIG. 9.

