

[54] **BICYCLE BRAKE BLOCK**

[75] **Inventor: Andrew J. King, London, England**

[73] **Assignee: Madison Cycles Limited, London, England**

[**] **Term: 14 Years**

[21] **Appl. No.: 479,480**

[22] **Filed: Mar. 28, 1983**

[30] **Foreign Application Priority Data**

Oct. 11, 1982 [GB] United Kingdom 1009181
[52] **U.S. Cl. D12/180**
[58] **Field of Search D12/180, 179; 188/73.1, 188/250 B**

[56] **References Cited
PUBLICATIONS**

Modolo Brochure, p. 1, Brake Blocks, bottom of page.

Primary Examiner—James M. Gandy
Attorney, Agent, or Firm—Scrivener, Clarke, Scrivener & Johnson

[57] **CLAIM**

The ornamental design for a bicycle brake block, as shown.

DESCRIPTION

FIG. 1 is a top plan view of a bicycle brake block showing my new design;
FIG. 2 is a side elevational view thereof;
FIG. 3 is an end elevational view thereof;
FIG. 4 is a bottom plan view thereof; and
FIG. 5 is a perspective view of the bottom side and one end thereof.

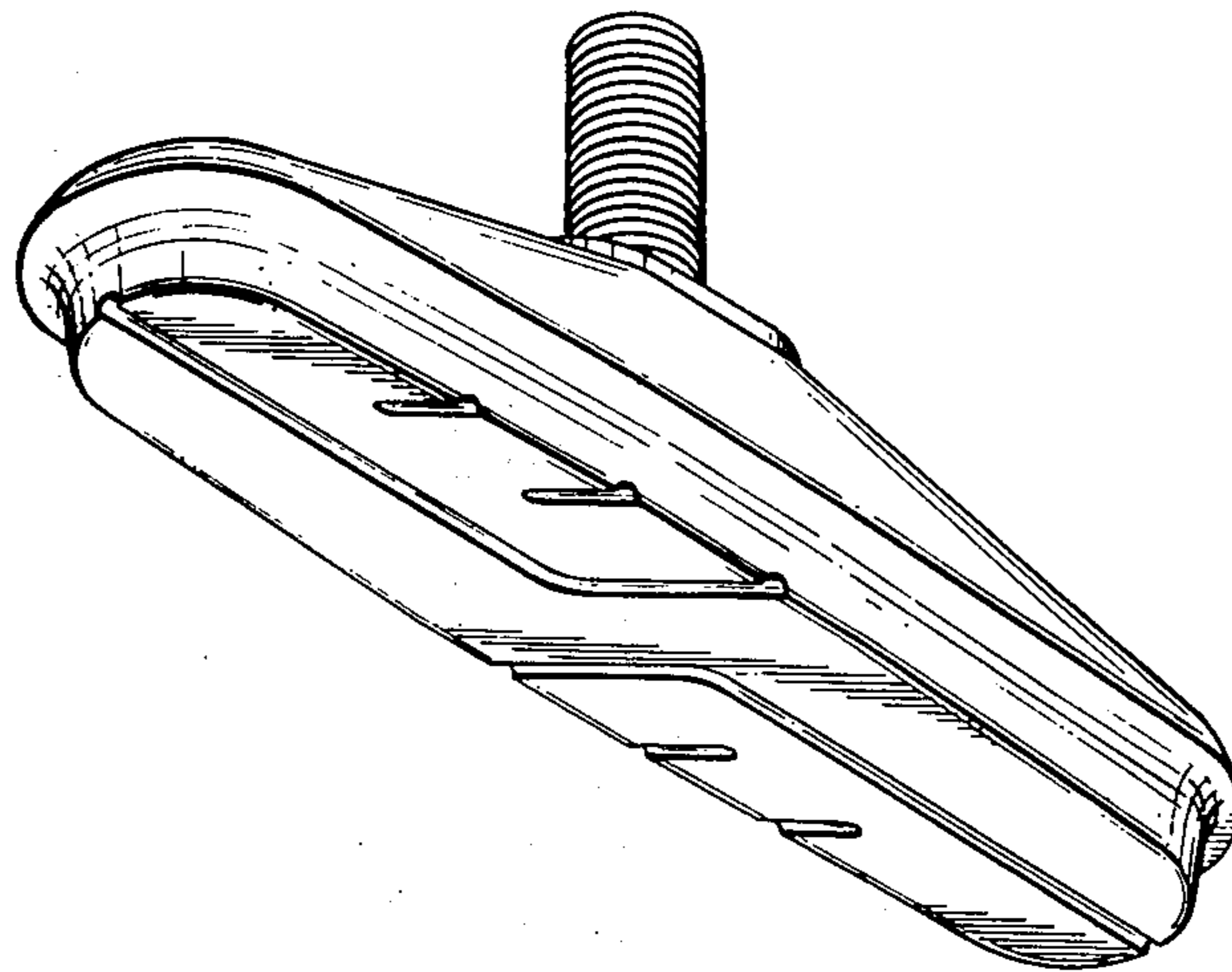

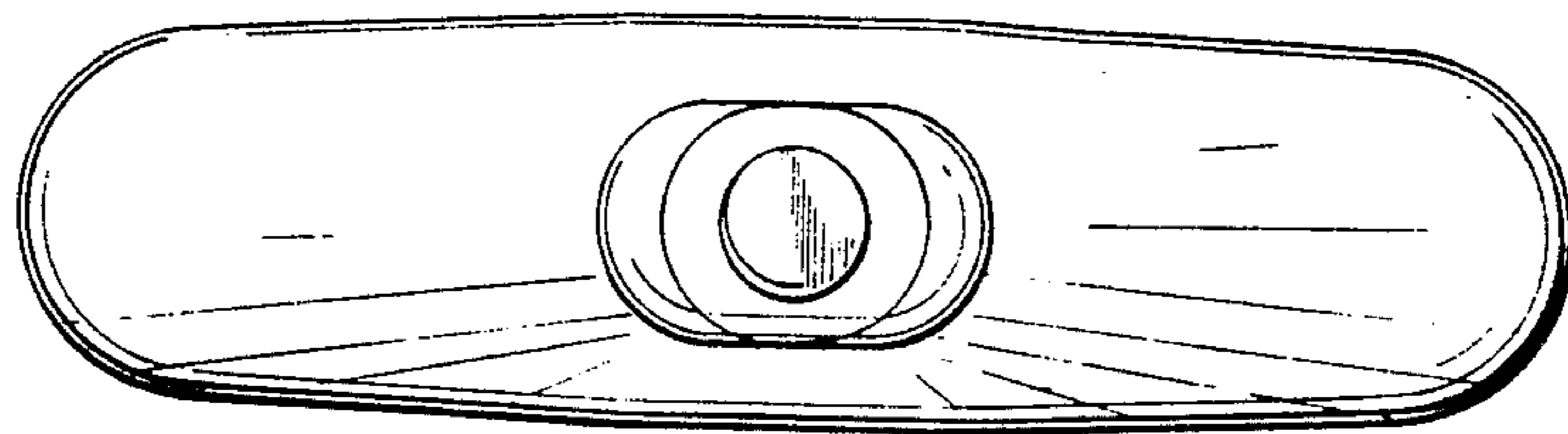

FIG. 1.

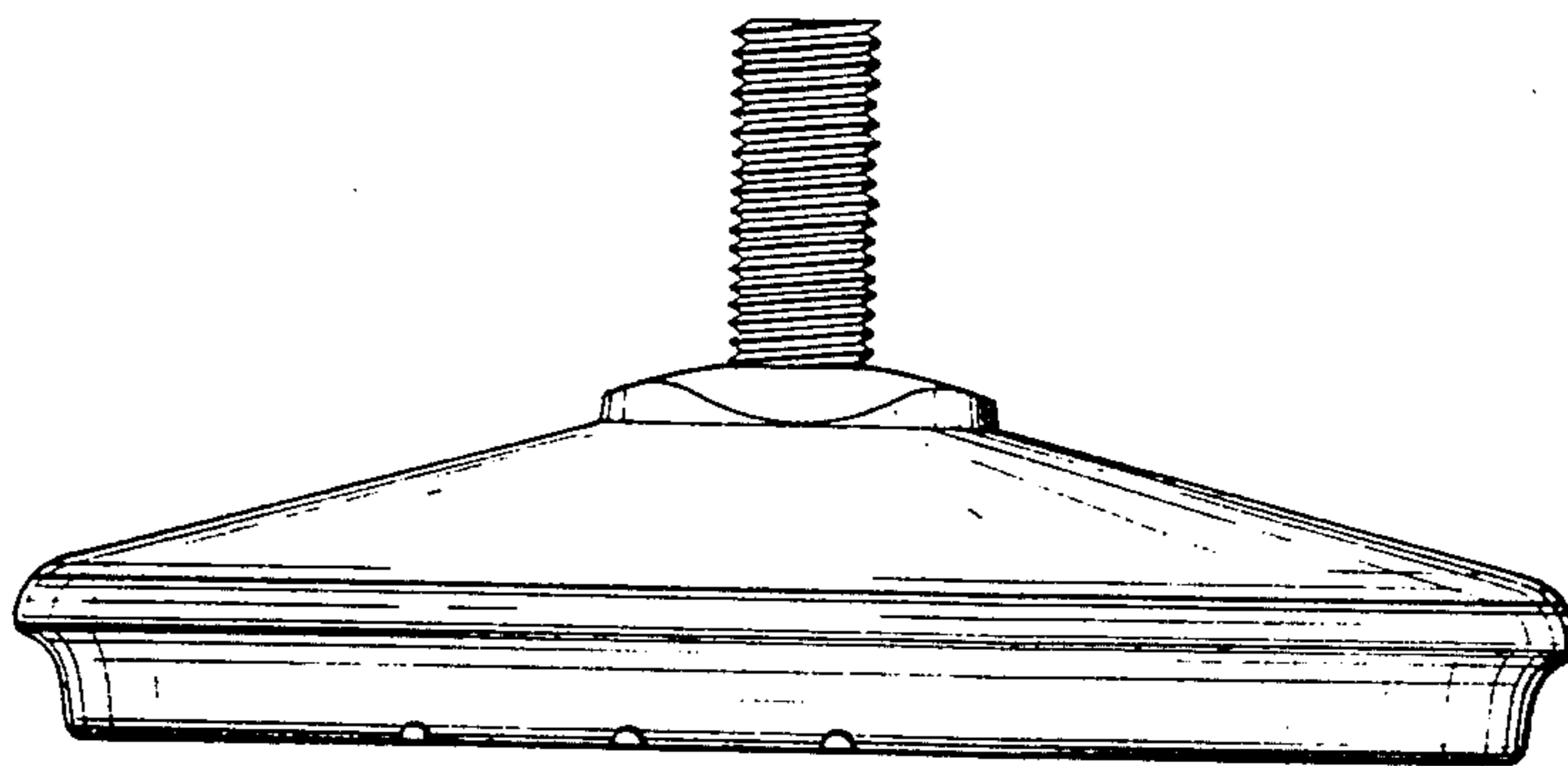

FIG. 2.

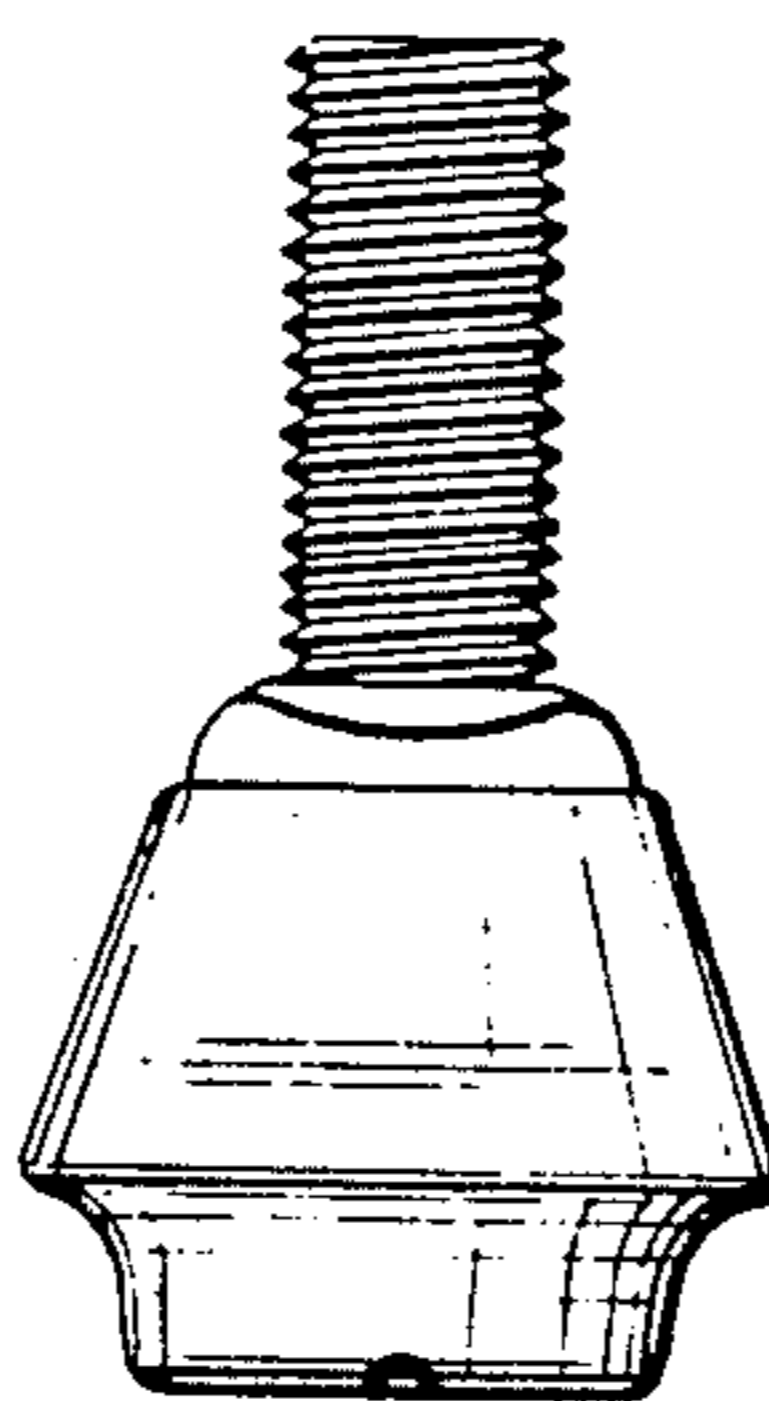

FIG. 3.

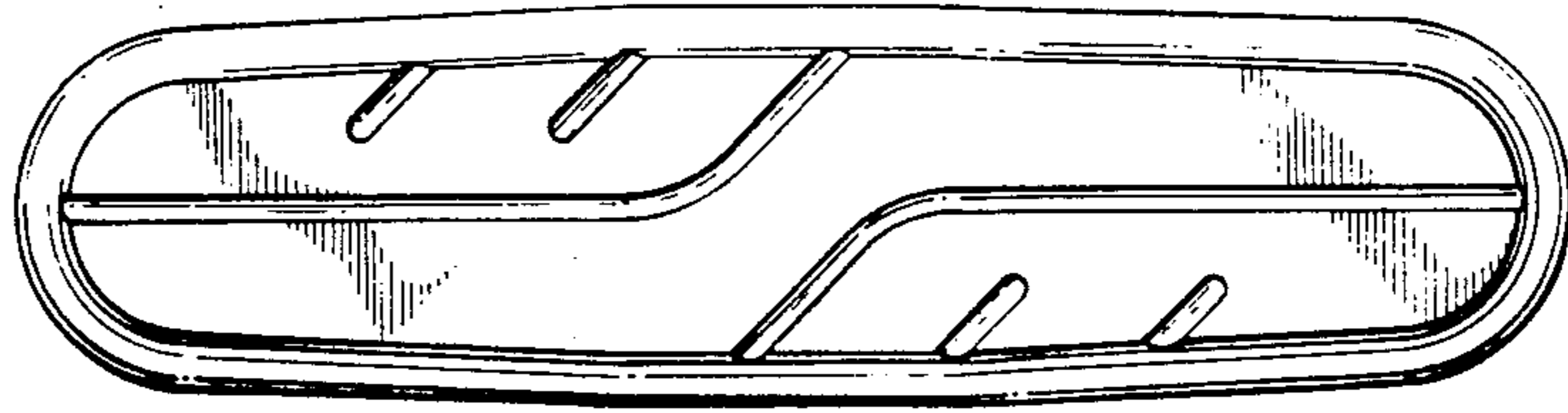

FIG. 4.

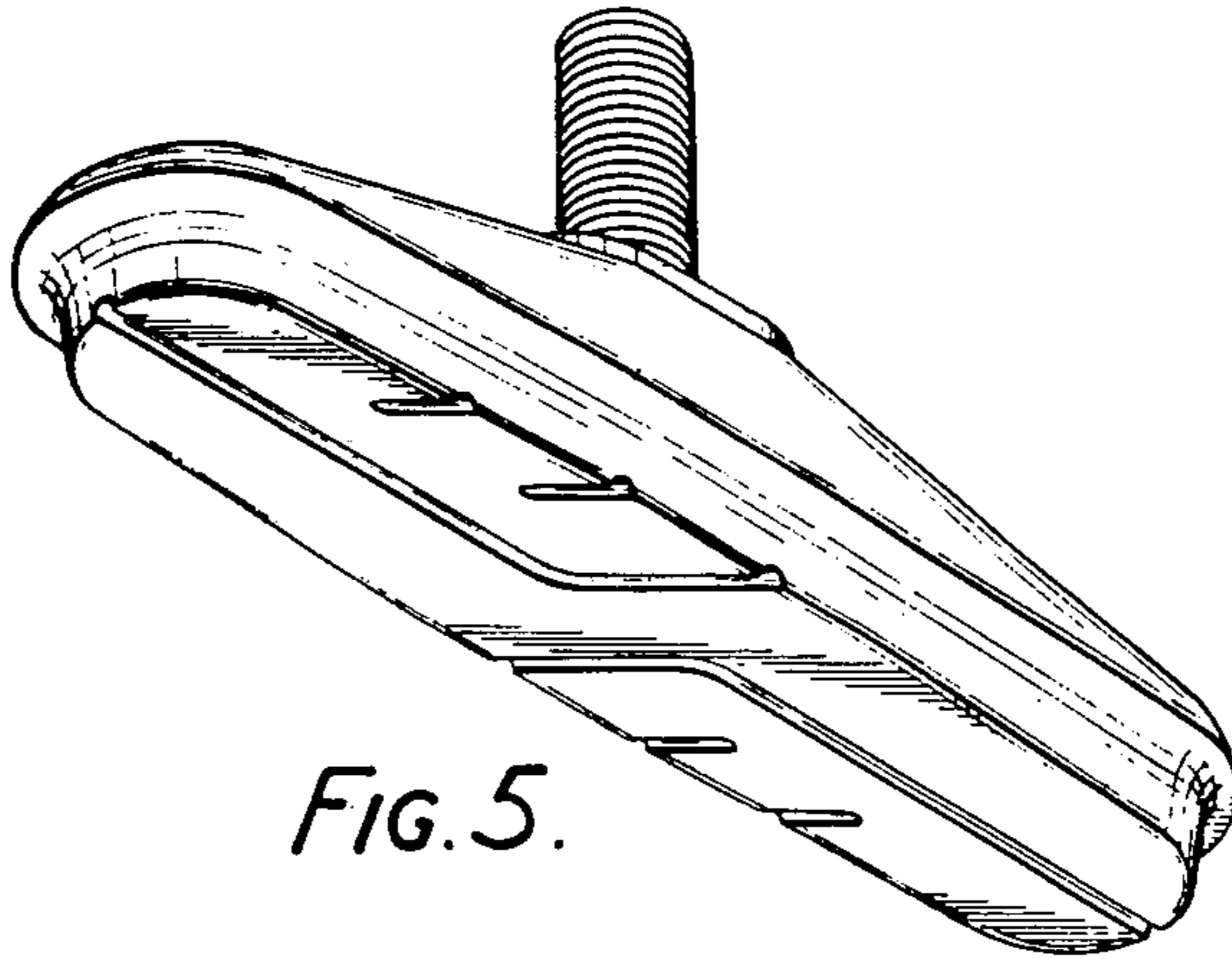

FIG. 5.