

[54] **FRONT BUMPER FOR AUTOMOBILE**

[75] **Inventors:** Richard A. Teague, Franklin; Robert C. Nixon; George M. Krispinsky, both of Huntington Woods; Jack E. Kenitz, New Baltimore; Gary D. Guichard, Dearborn Heights, all of Mich.

[73] **Assignee:** American Motors Corporation, Southfield, Mich.

[**] **Term:** 14 Years

[21] **Appl. No.:** 432,154

[22] **Filed:** Sep. 30, 1982

[52] **U.S. Cl.** D12/169

[58] **Field of Search** D12/169; 293/102, 120

[56] **References Cited
PUBLICATIONS**

Motor Trend, 3/81, p. 90, Front Bumper of Toyota Cressida, lower left side of page.

Motor Trend, 8/81, p. 63, Front Bumper of Audi 5000 Turbo, center of page.

Primary Examiner—James M. Gandy

[57] **CLAIM**

The ornamental design for a front bumper for an automobile, as shown and described.

DESCRIPTION

FIG. 1 is a perspective view of the front and one side of a front bumper for an automobile showing our new design;

FIG. 2 is a perspective view of the front and opposite side thereof;

FIG. 3 is an enlarged side elevational view thereof;

FIG. 4 is an enlarged front elevational view thereof; and

FIG. 5 is an enlarged top plan view thereof.

The broken lines in the drawings are for illustrative purposes only.

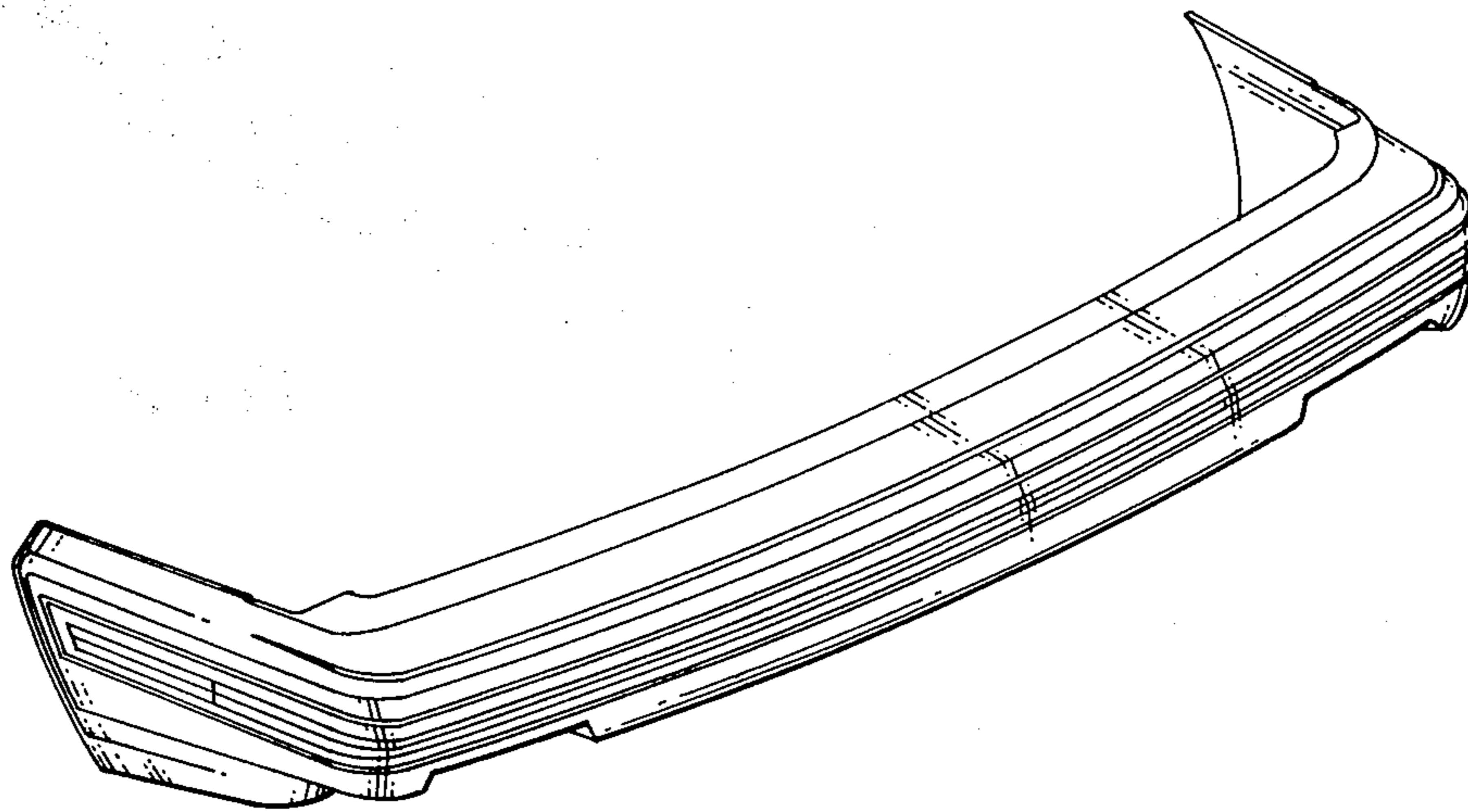

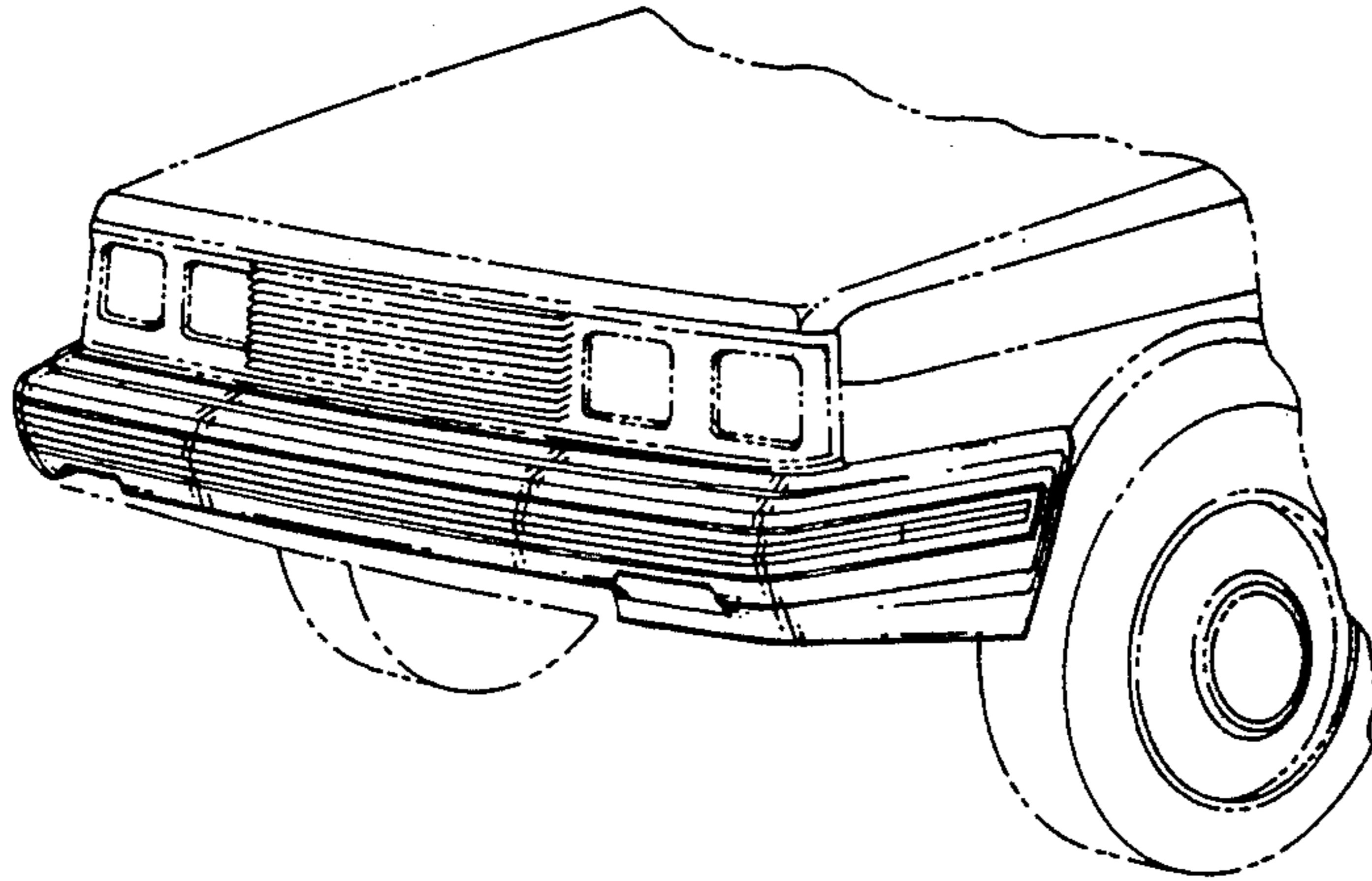

Fig. 1

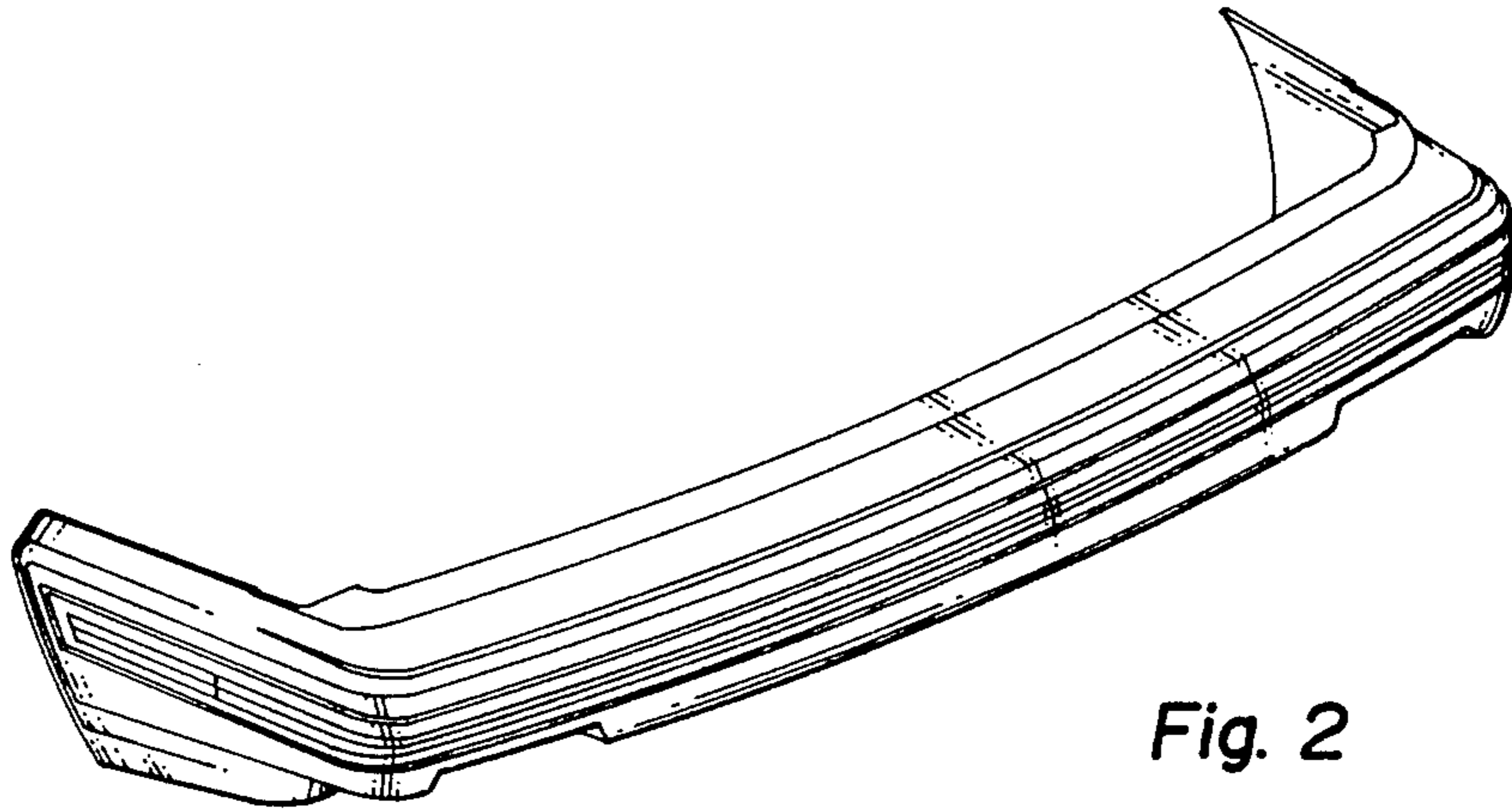
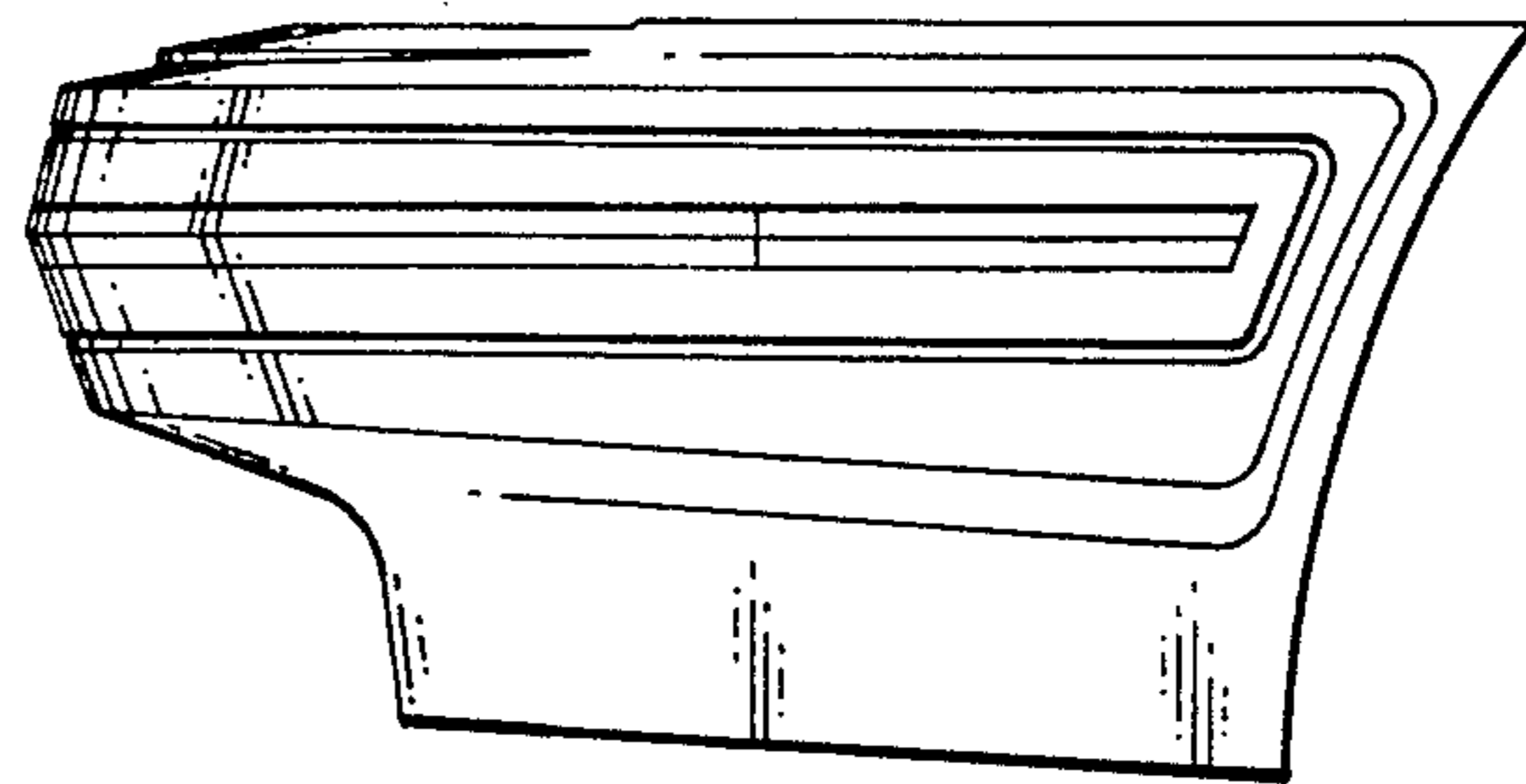

Fig. 2

Fig. 3



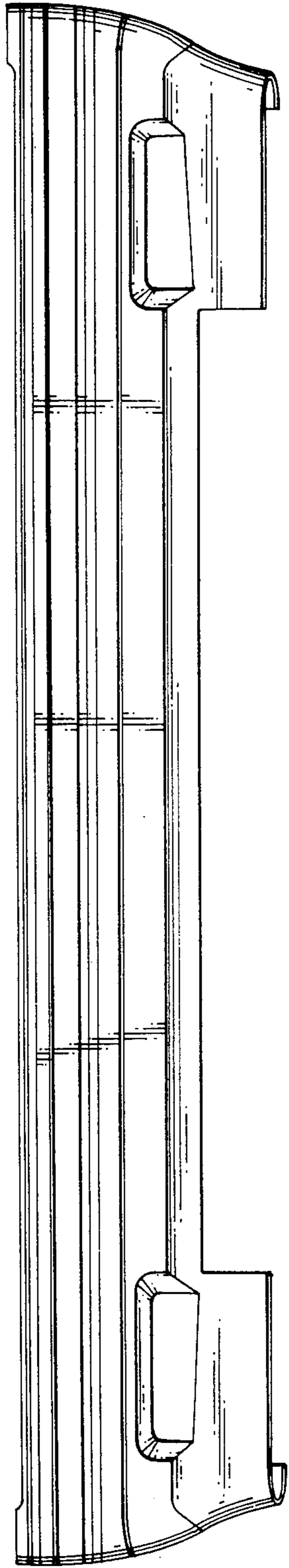

Fig. 4

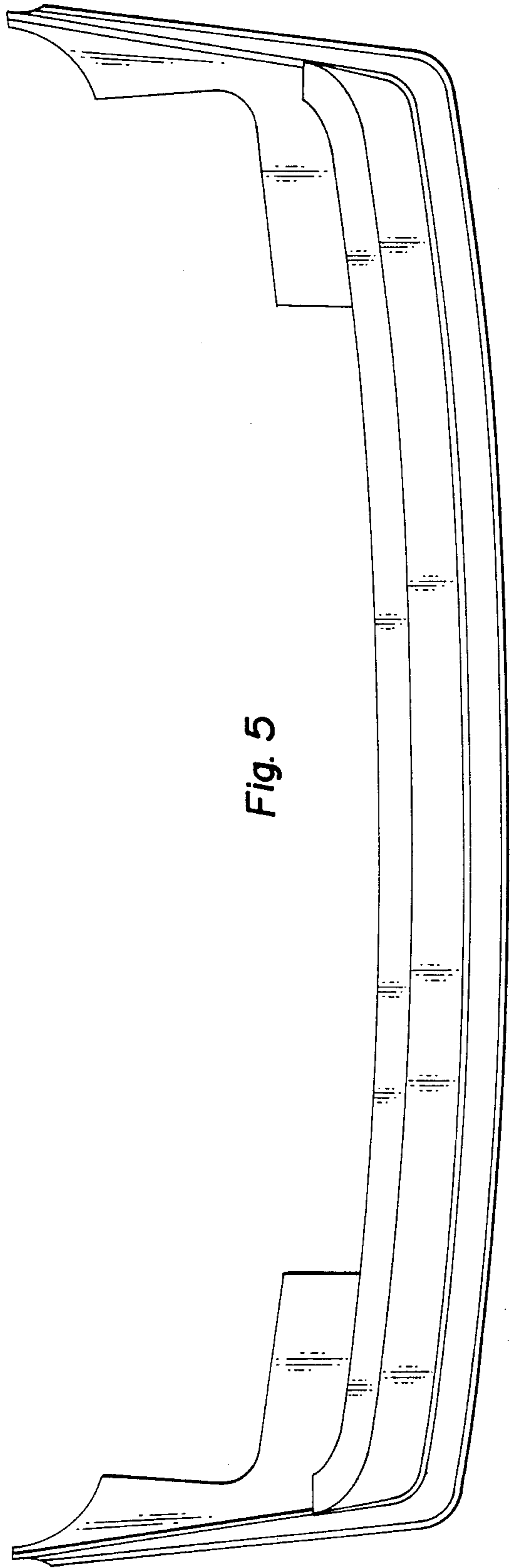

Fig. 5