

[54] **MOTORCYCLE**

[75] **Inventor: Koji Nakano, Saitama, Japan**

[73] **Assignee: Honda Giken Kogyo Kabushiki Kaisha, Tokyo, Japan**

[**] **Term: 14 Years**

[21] **Appl. No.: 359,570**

[22] **Filed: Mar. 18, 1982**

[30] **Foreign Application Priority Data**

Sep. 21, 1981 [JP] Japan 56-42269

[52] **U.S. Cl. D12/110**

[58] **Field of Search D12/110; 180/219**

[56] **References Cited**

PUBLICATIONS

Cycle World, 4/81, p. 68, Suzuki GS1100.

Cycle World, 9/81, p. 29, Suzuki GS750.

Cycle World, 5/81, p. 51, Honda Motorcycle, bottom of page.

Cycle World, 3/81, p. 103, Honda CB750F.

Primary Examiner—James M. Gandy

Attorney, Agent, or Firm—Irving M. Weiner; Joseph P. Carrier; John J. Cantarella

[57] **CLAIM**

The ornamental design for a motorcycle, as shown.

DESCRIPTION

FIG. 1 is a perspective view of a motorcycle showing my new design;

FIG. 2 is a front elevational view thereof;

FIG. 3 is a right side elevational view thereof;

FIG. 4 is a rear elevational view thereof;

FIG. 5 is a top plan view thereof; and

FIG. 6 is a left side elevational view thereof.

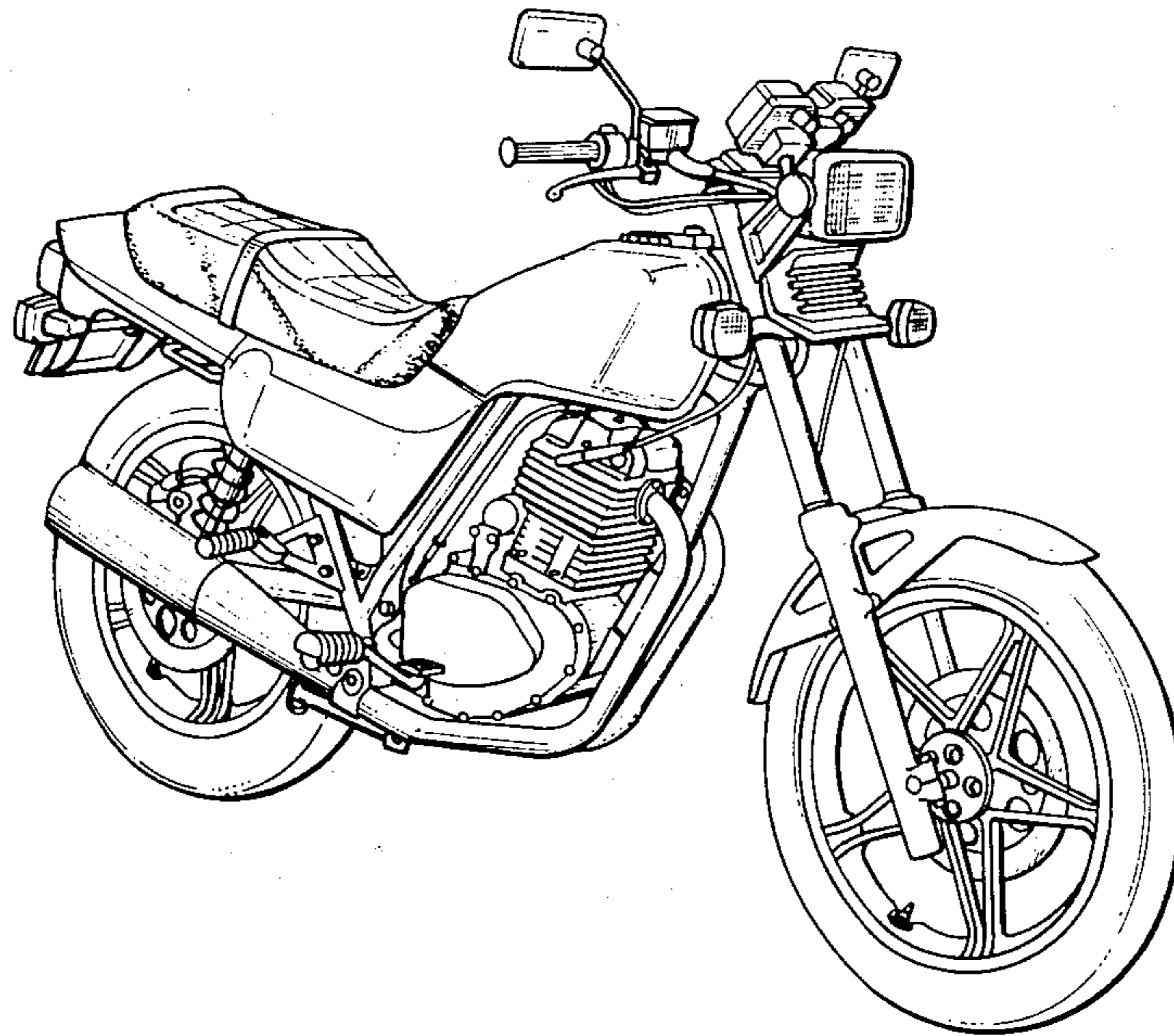

FIG. 2

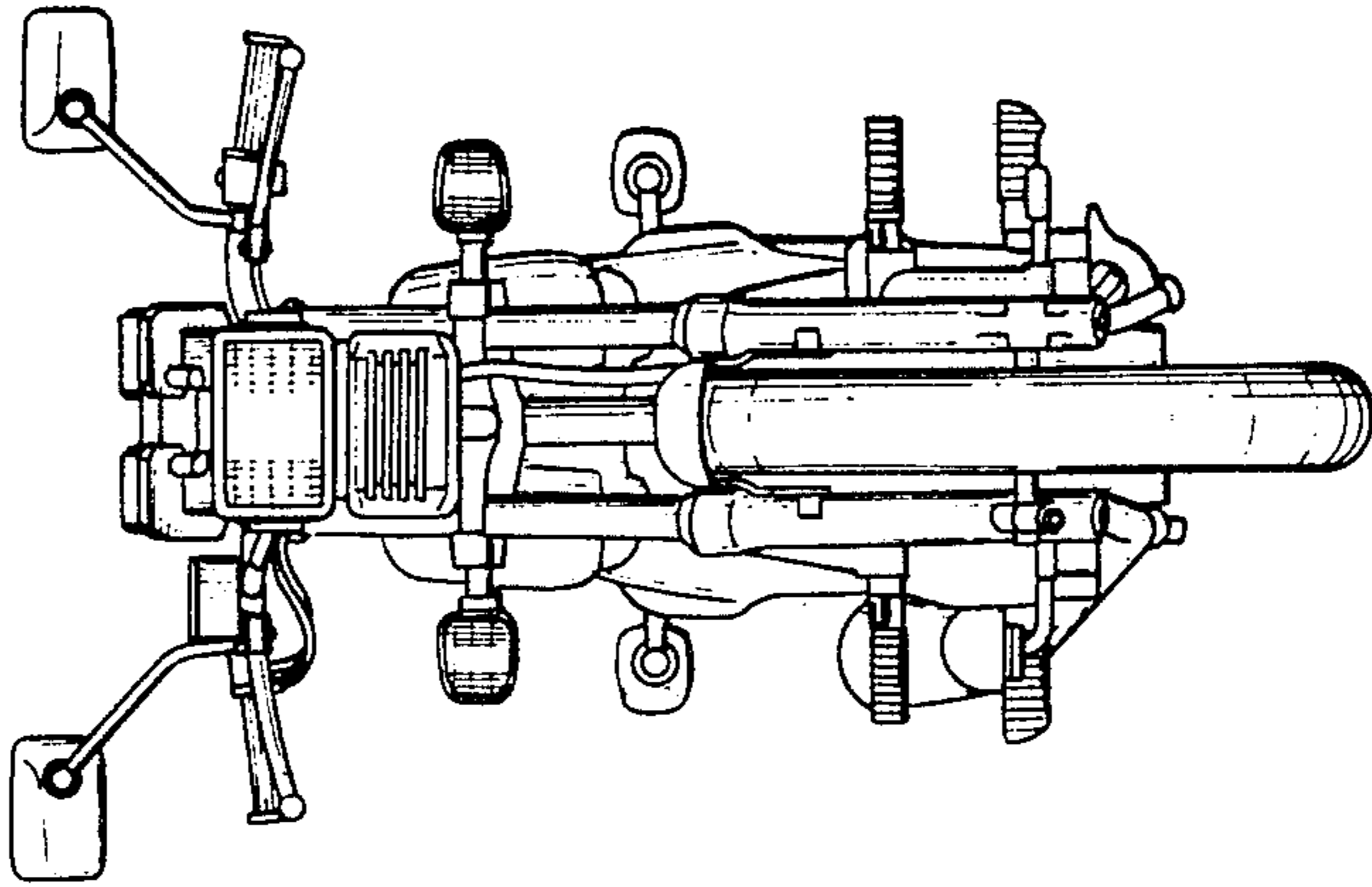

FIG. 1

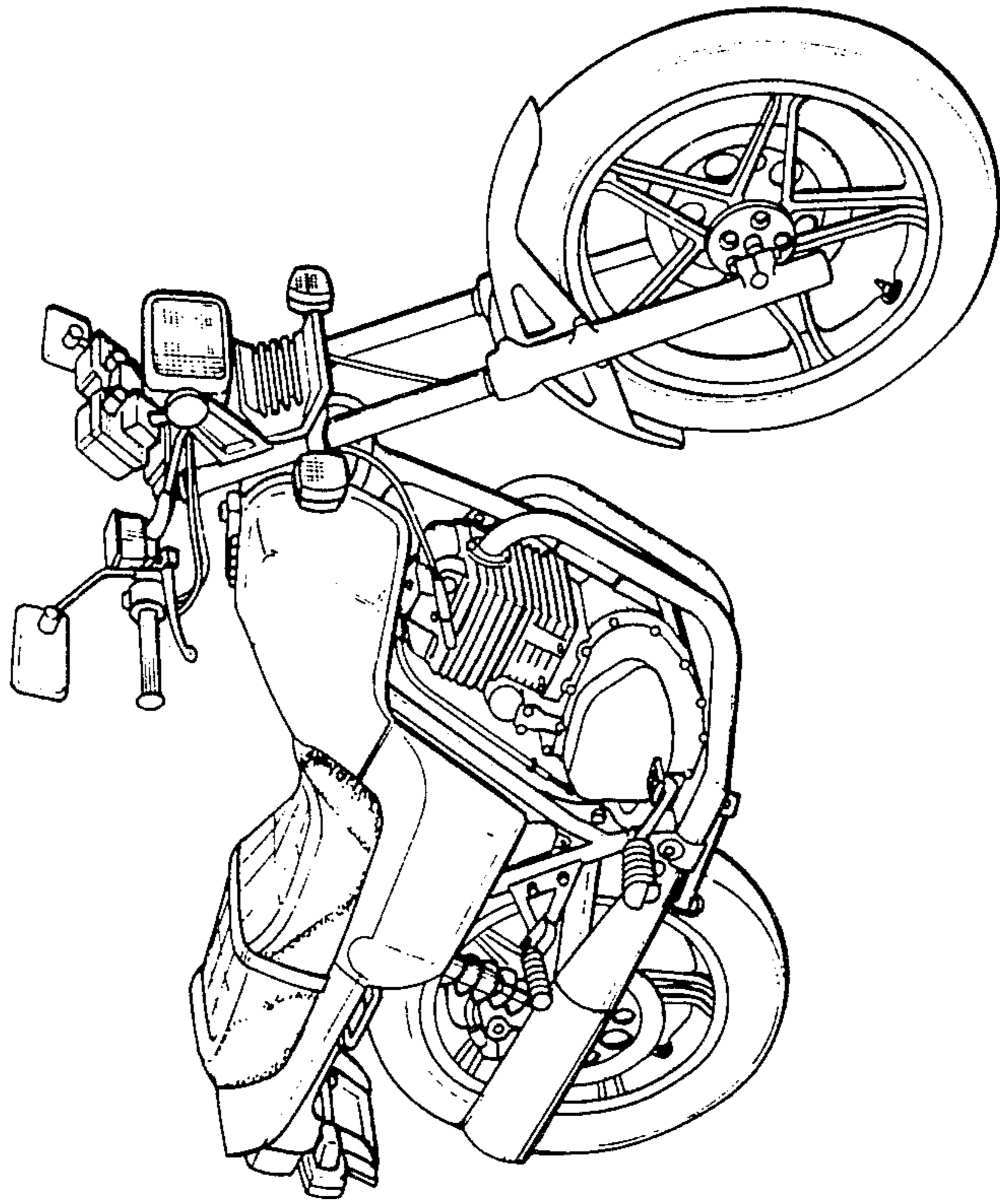

FIG. 3

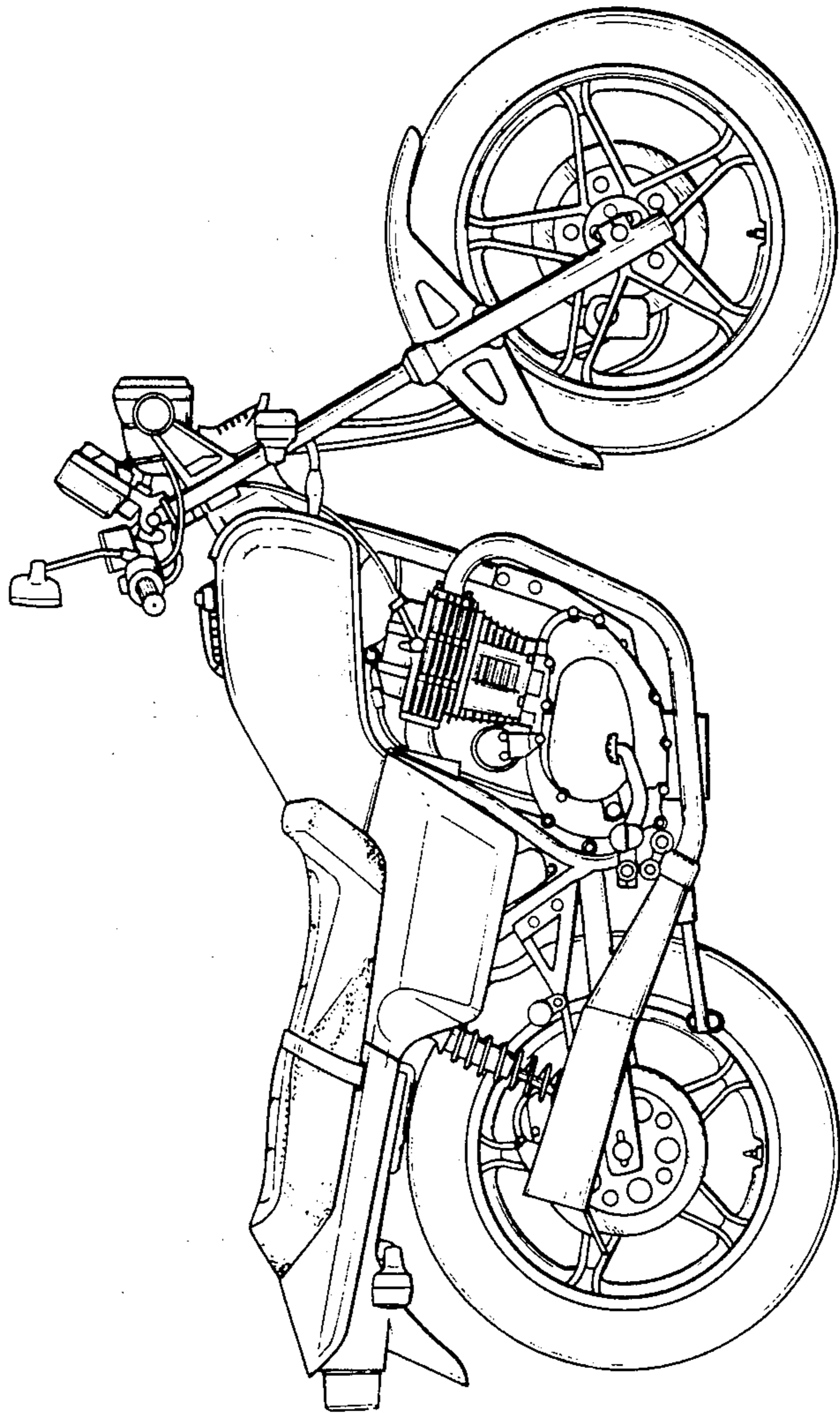

FIG. 4

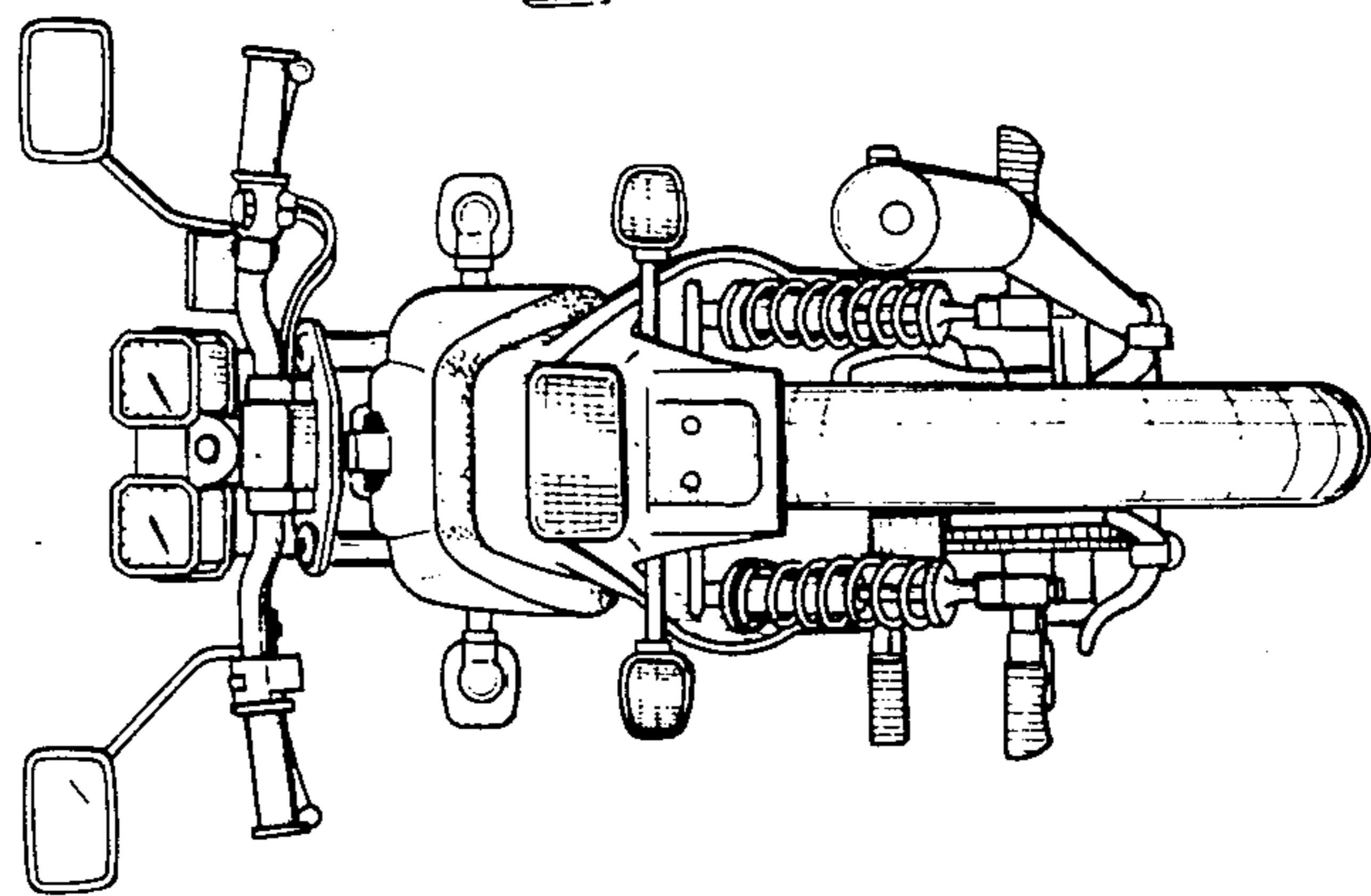

FIG. 5

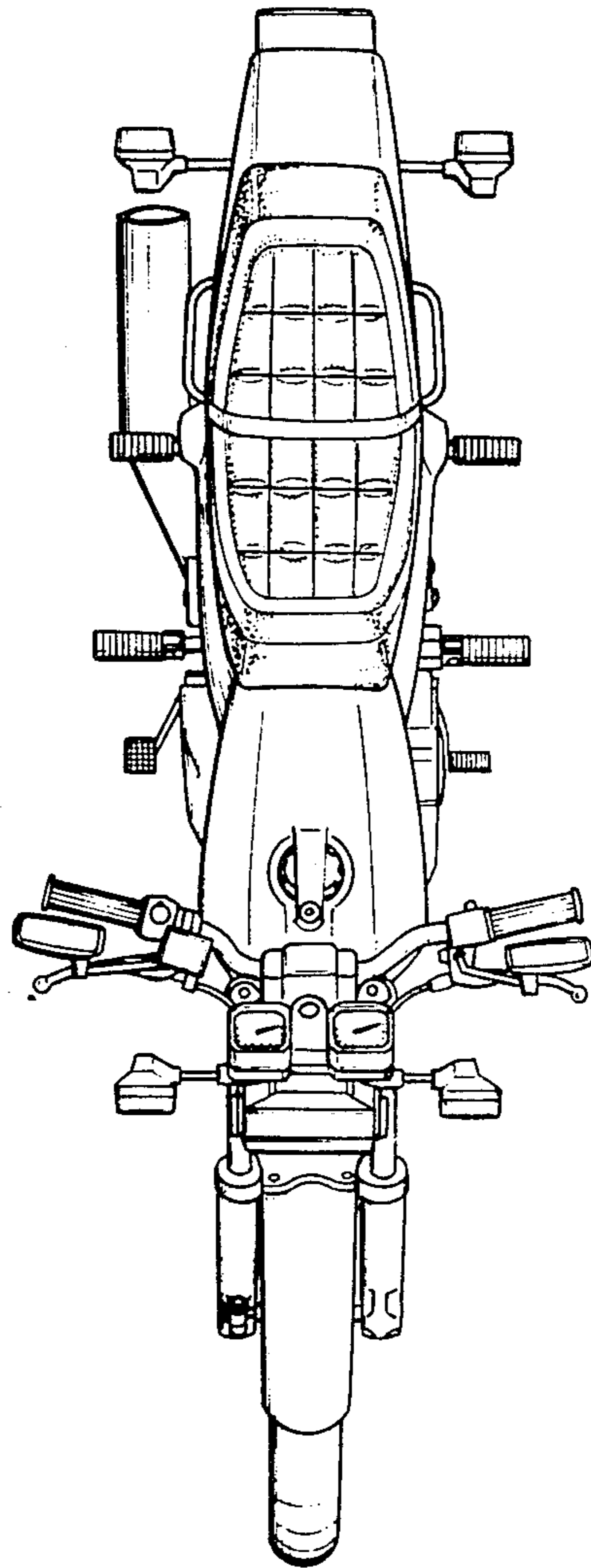

FIG. 6

