

United States Patent [19]

Nakao et al.

[11] Patent Number: **Des. 281,792**

[45] Date of Patent: **** Dec. 17, 1985**

[54] **TOY VEHICLE**

[75] Inventors: **Shinroku Nakao, Kanagawa; Yoshiyasu Ishii; Taira Hanashima,** both of Tokyo, all of Japan

[73] Assignee: **Combi Co., Ltd., Tokyo, Japan**

[**] Term: **14 Years**

[21] Appl. No.: **547,282**

[22] Filed: **Oct. 31, 1983**

[30] **Foreign Application Priority Data**

May 18, 1983 [JP] Japan 58-20778

[52] U.S. Cl. **D21/78**

[58] Field of Search D21/76, 78, 79, 80, D21/81, 128, 131, 132, 133, 134, 135, 136, 137, 139, 140; 446/433, 440, 451, 465, 466; 280/87.01, 87.02 R, 87.02

[56] **References Cited**

U.S. PATENT DOCUMENTS

D. 226,014 1/1973 Ogasawara D21/139

D. 246,481 11/1977 Nakao D21/78
D. 252,829 9/1979 Nakao et al. D21/78
D. 272,551 2/1984 Nakao et al. D21/78
D. 274,442 6/1984 Appel et al. D21/78

OTHER PUBLICATIONS

Sears Toy Catalog, 1982, p. 599, Item #7, "Toy Swivel Crane".

Primary Examiner—Charles A. Rademaker
Attorney, Agent, or Firm—Sughrue, Mion, Zinn, Macpeak & Seas

[57] **CLAIM**

The ornamental design for a toy vehicle, as shown.

DESCRIPTION

FIG. 1 is a front, top and right side perspective view of a toy vehicle showing our new design; FIG. 2 is a front elevational view thereof; FIG. 3 is a left side elevational view thereof; FIG. 4 is a rear elevational view thereof; FIG. 5 is a left side elevational view thereof; FIG. 6 is a top plan view thereof; and FIG. 7 is a bottom plan view thereof.

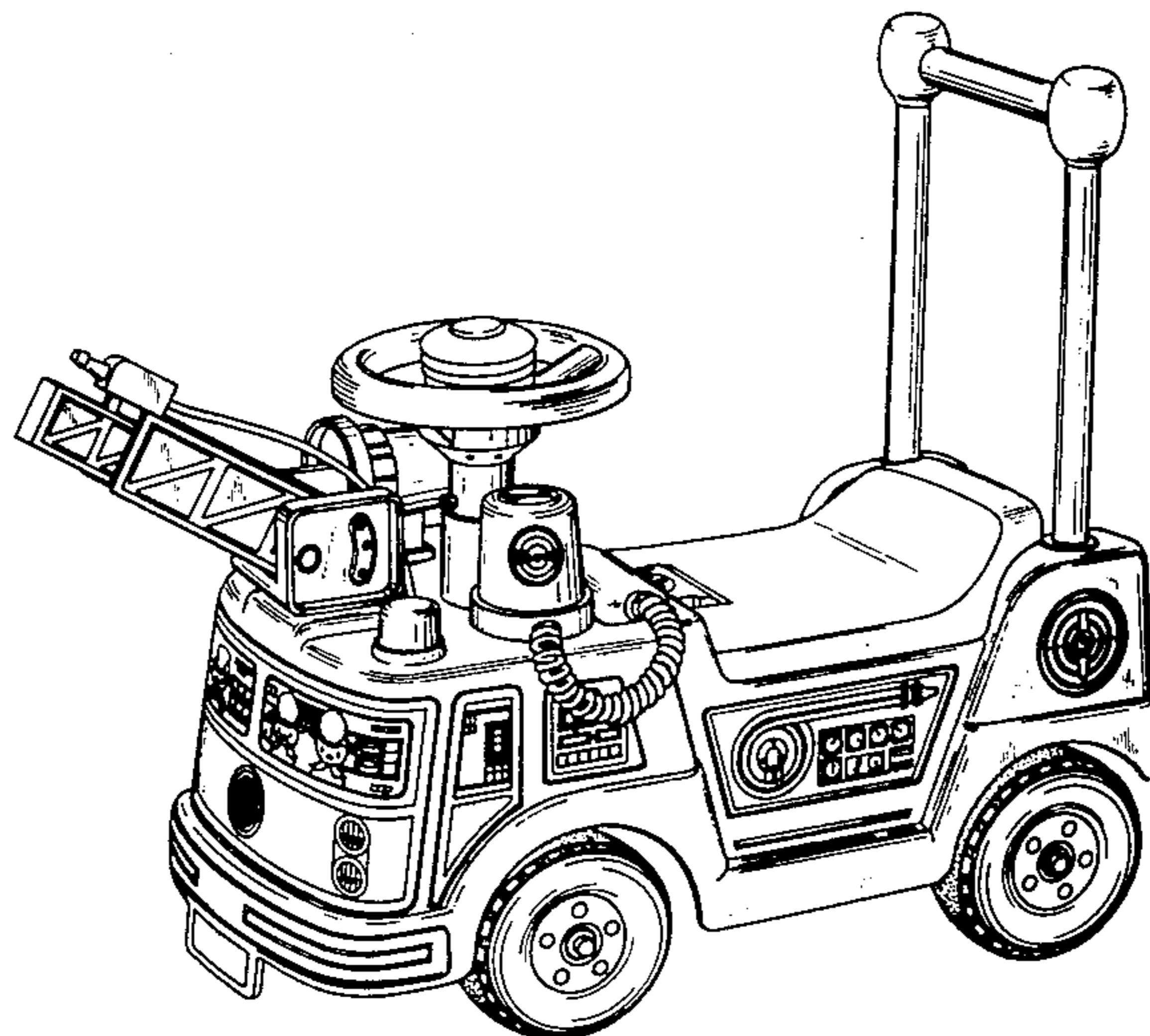

FIG. 1

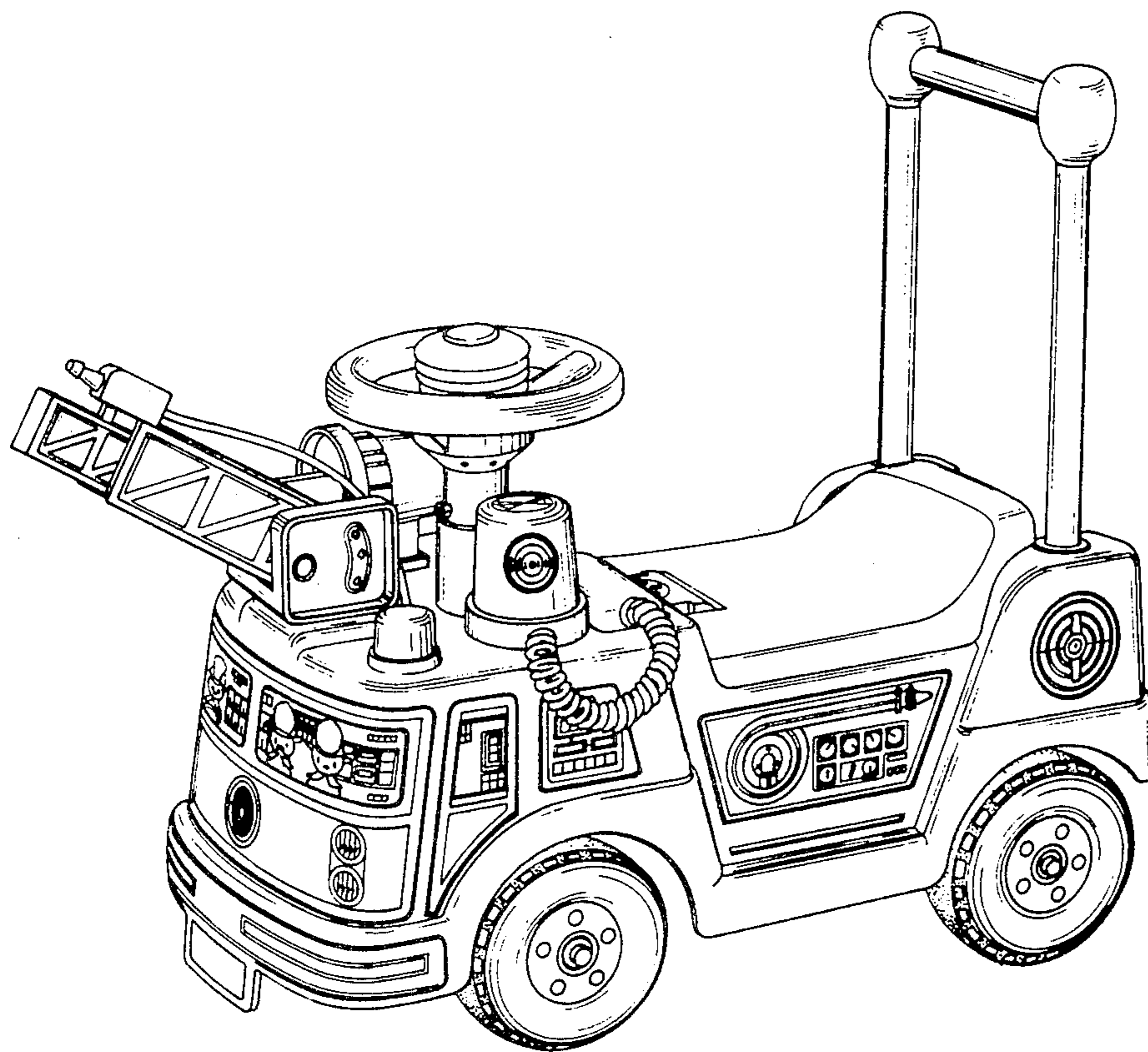

FIG. 2

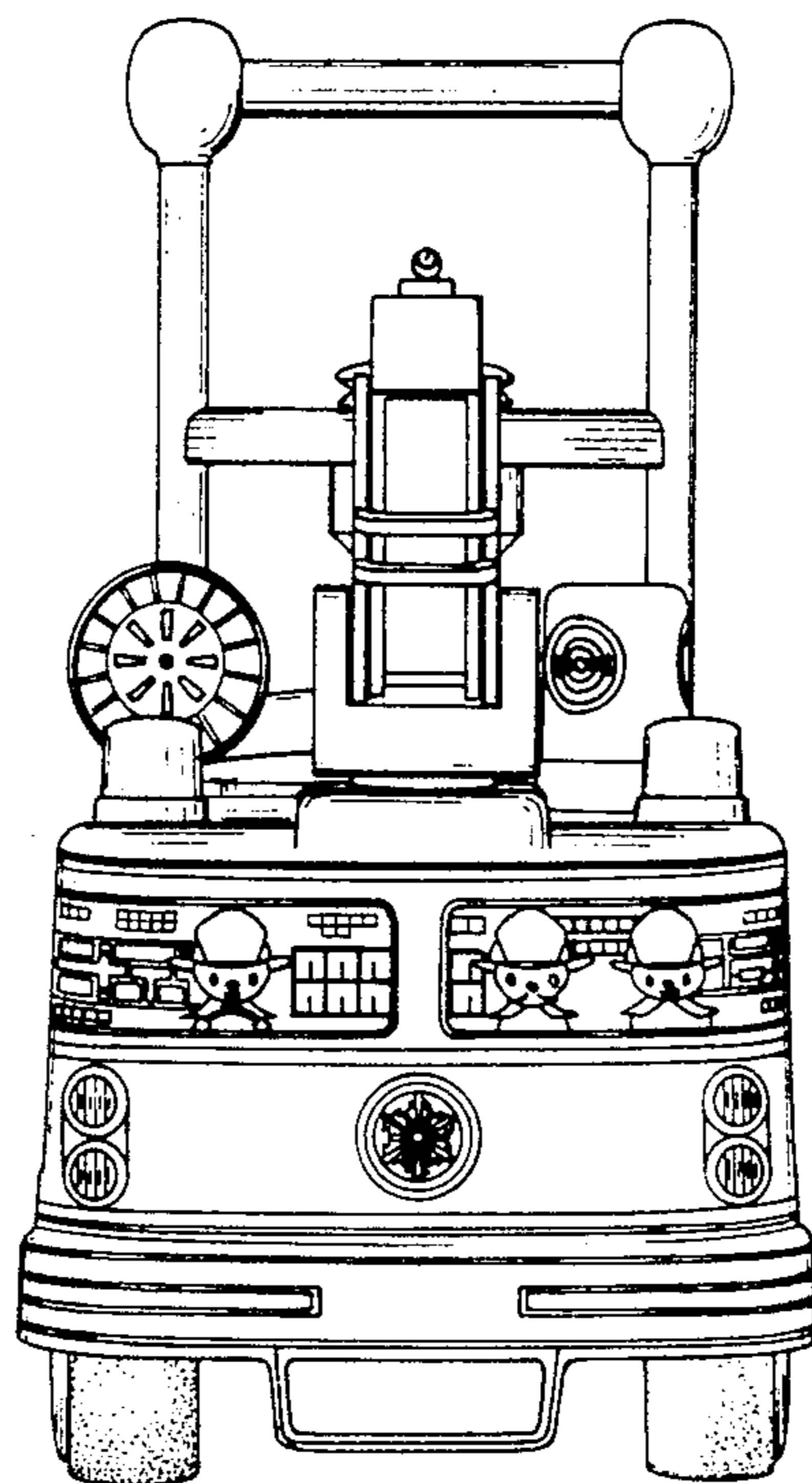

FIG. 3

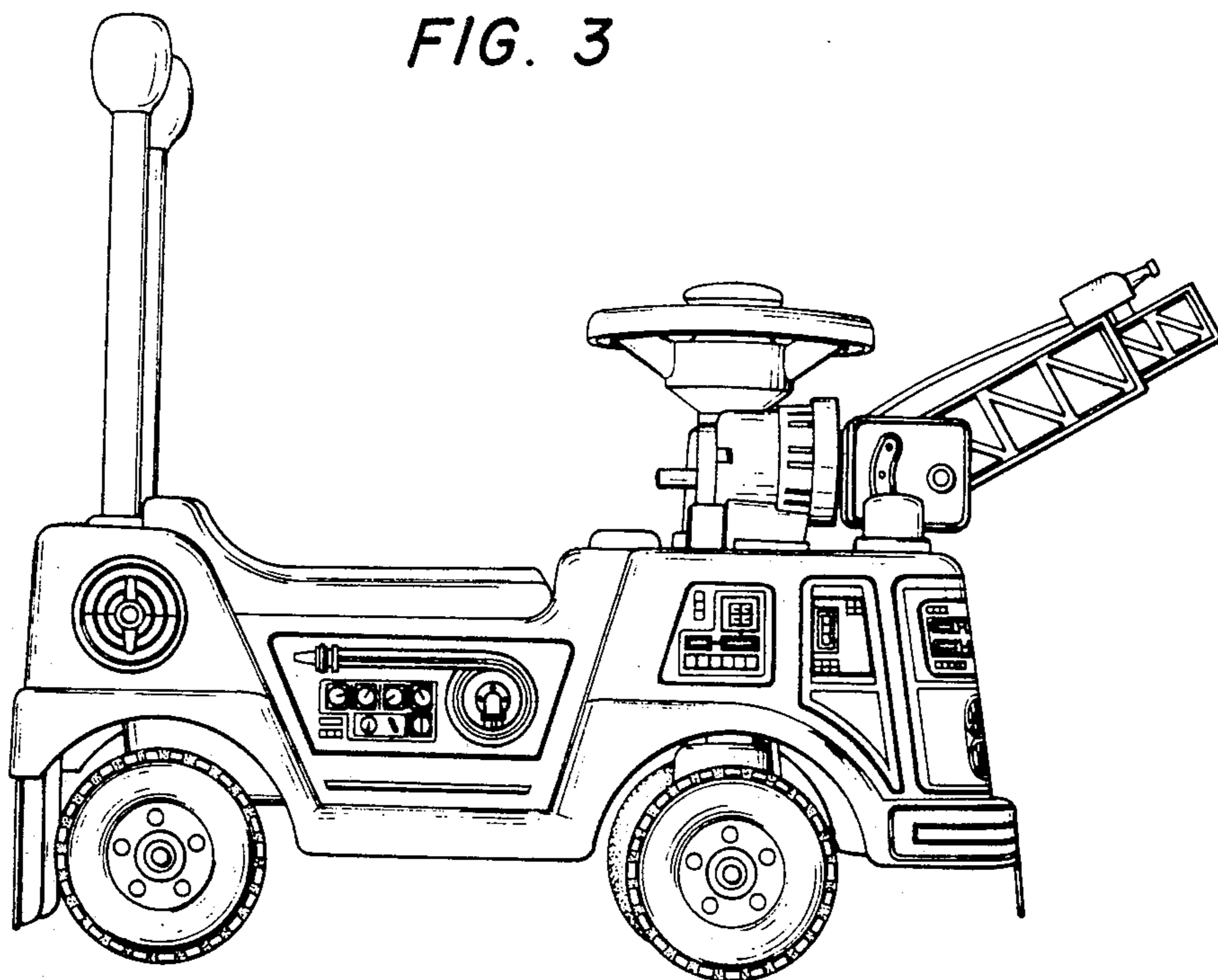

FIG. 4

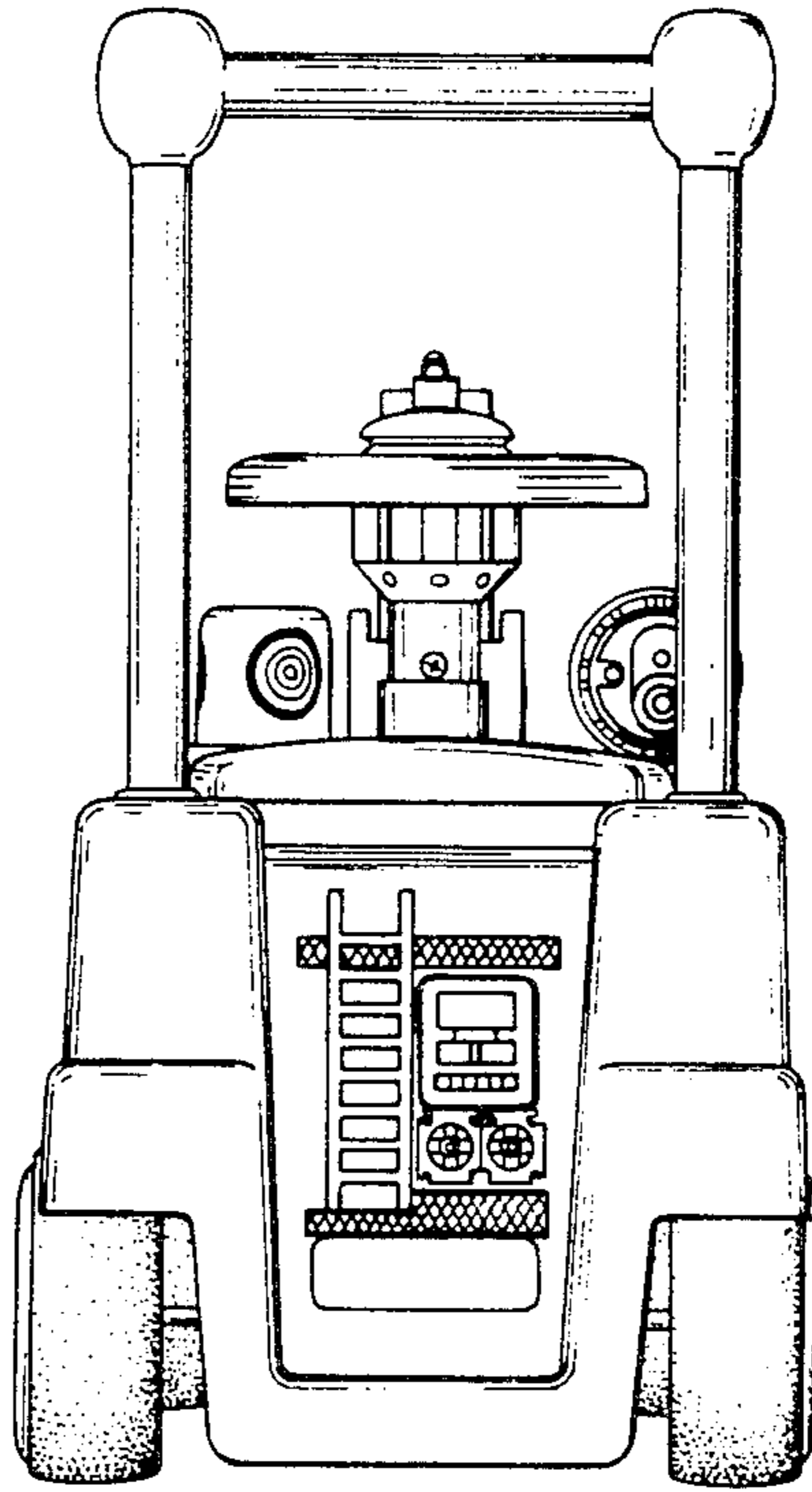

FIG. 5

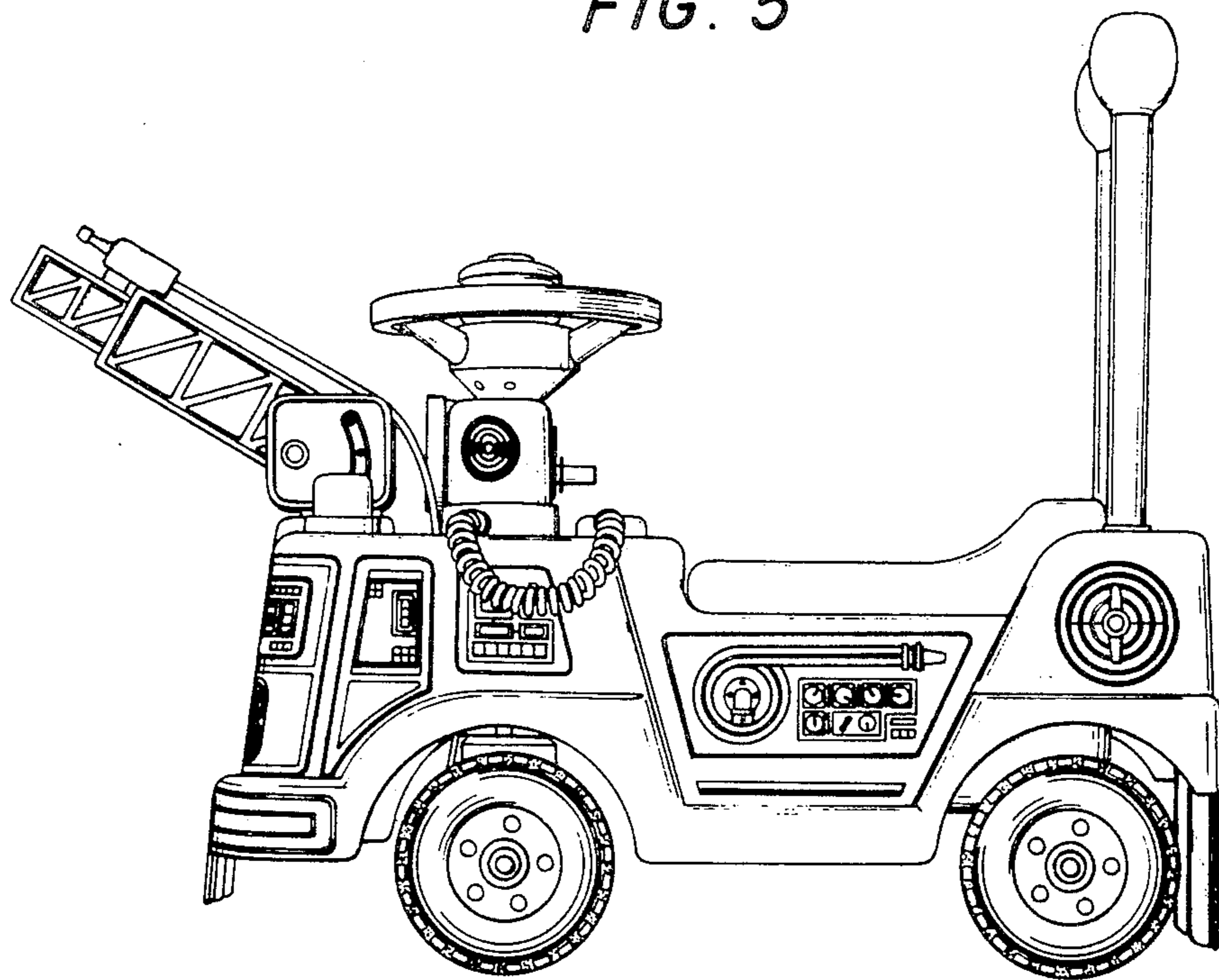

FIG. 6

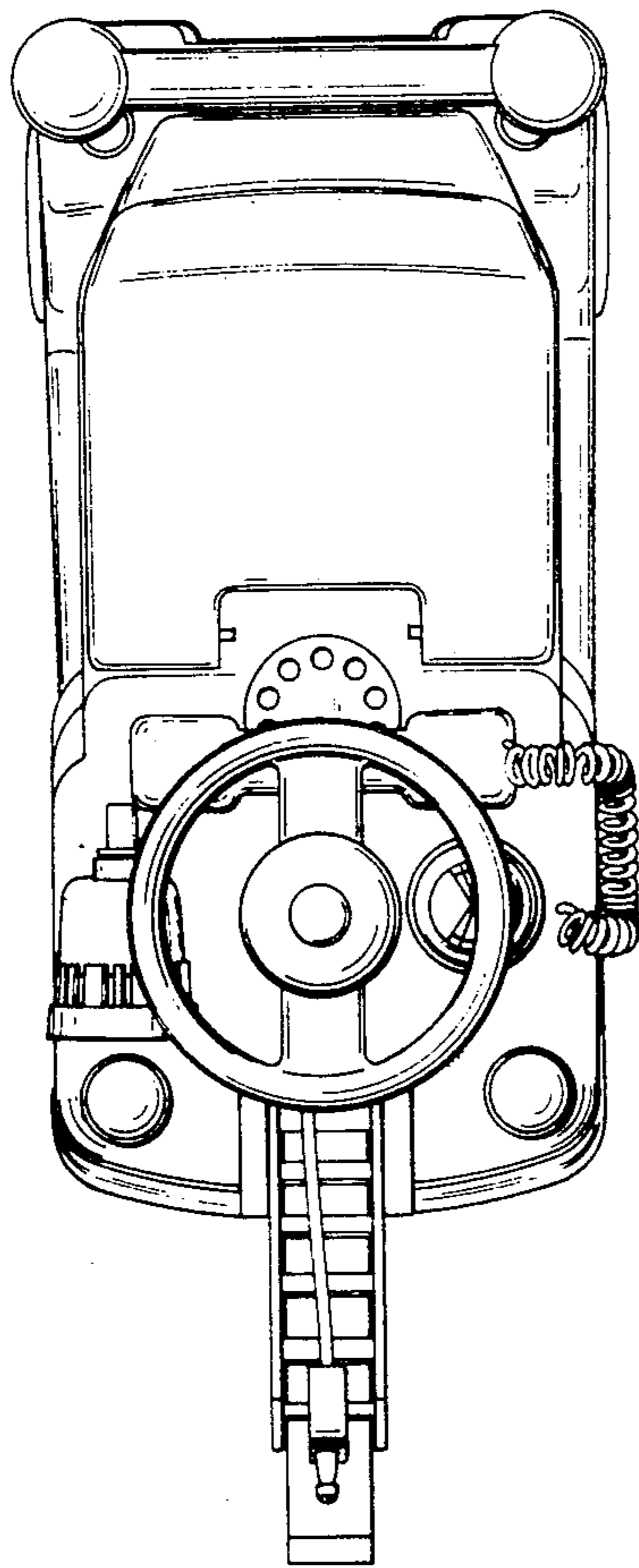

FIG. 7

