

[54] **MOTORCYCLE MANIFOLD COVER**

[75] **Inventors: Alwin J. Stahel, St. Paul; Thomas H. Rudd, Wayzata, both of Minn.**

[73] **Assignee: Drag Specialties, Inc., Minneapolis, Minn.**

[**] **Term: 14 Years**

[21] **Appl. No.: 478,418**

[22] **Filed: Mar. 23, 1983**

[52] **U.S. Cl. D12/126**

[58] **Field of Search D12/114, 126; 280/289 G, 289 R; 180/219**

[56] **References Cited**

U.S. PATENT DOCUMENTS

- D. 170,077 7/1953 Brown D12/114
- D. 258,126 2/1981 Taylor D12/114

Primary Examiner—James M. Gandy
Attorney, Agent, or Firm—Kinney & Lange

[57] **CLAIM**

The ornamental design for a motorcycle manifold cover, as shown and described.

DESCRIPTION

FIG. 1 is a left side elevational view of a motorcycle manifold cover embodying my new design in a position of use, it being understood that the broken lines are for illustration purposes only;

FIG. 2 is an enlarged left side elevational view thereof; FIG. 3 is an enlarged right side elevational view thereof;

FIG. 4 is an enlarged top plan view thereof;

FIG. 5 is an enlarged bottom plan view thereof; and

FIG. 6 is an enlarged front elevational view thereof, the rear elevational view being substantially a mirror image thereof.

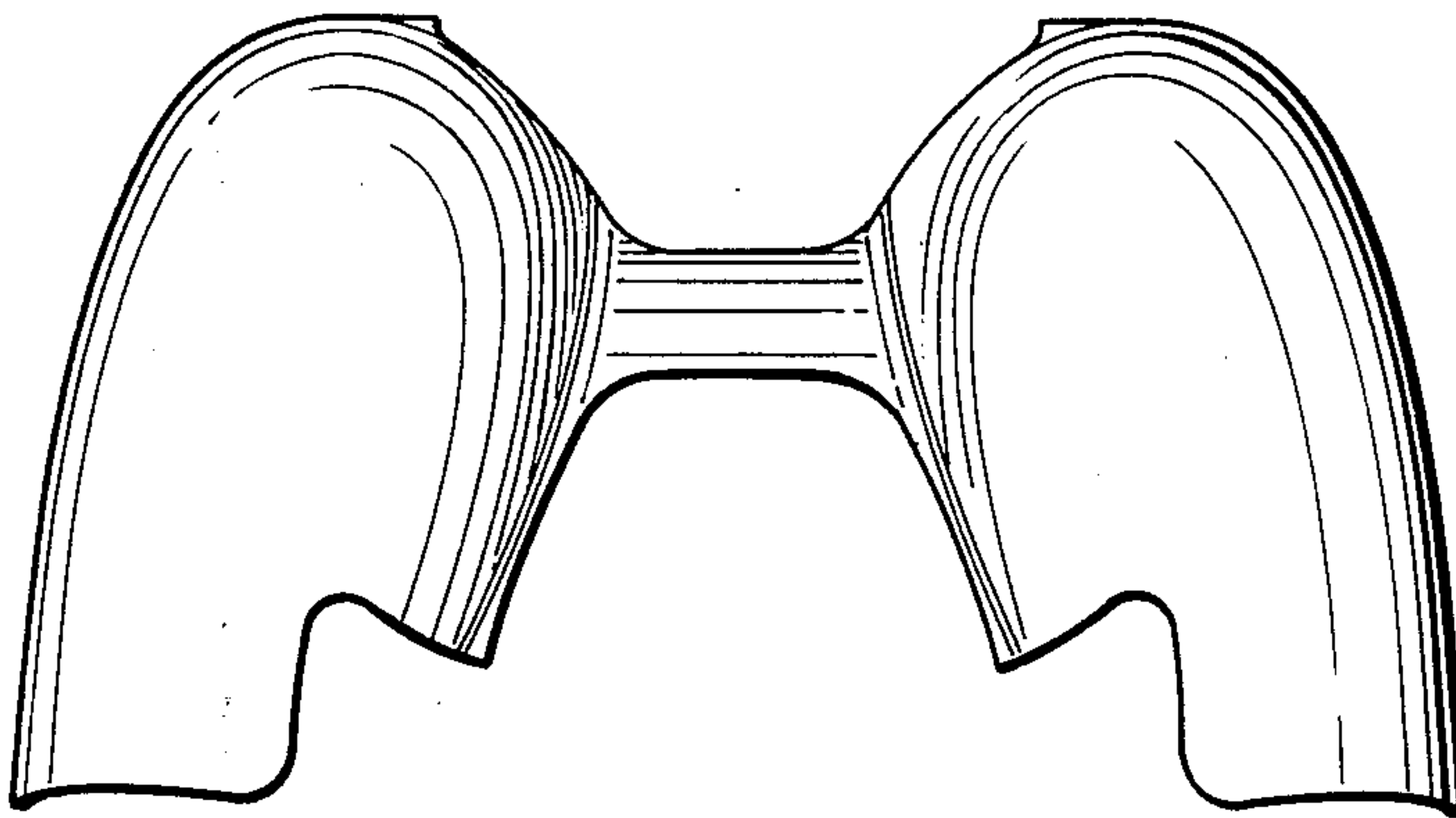

Fig. 1

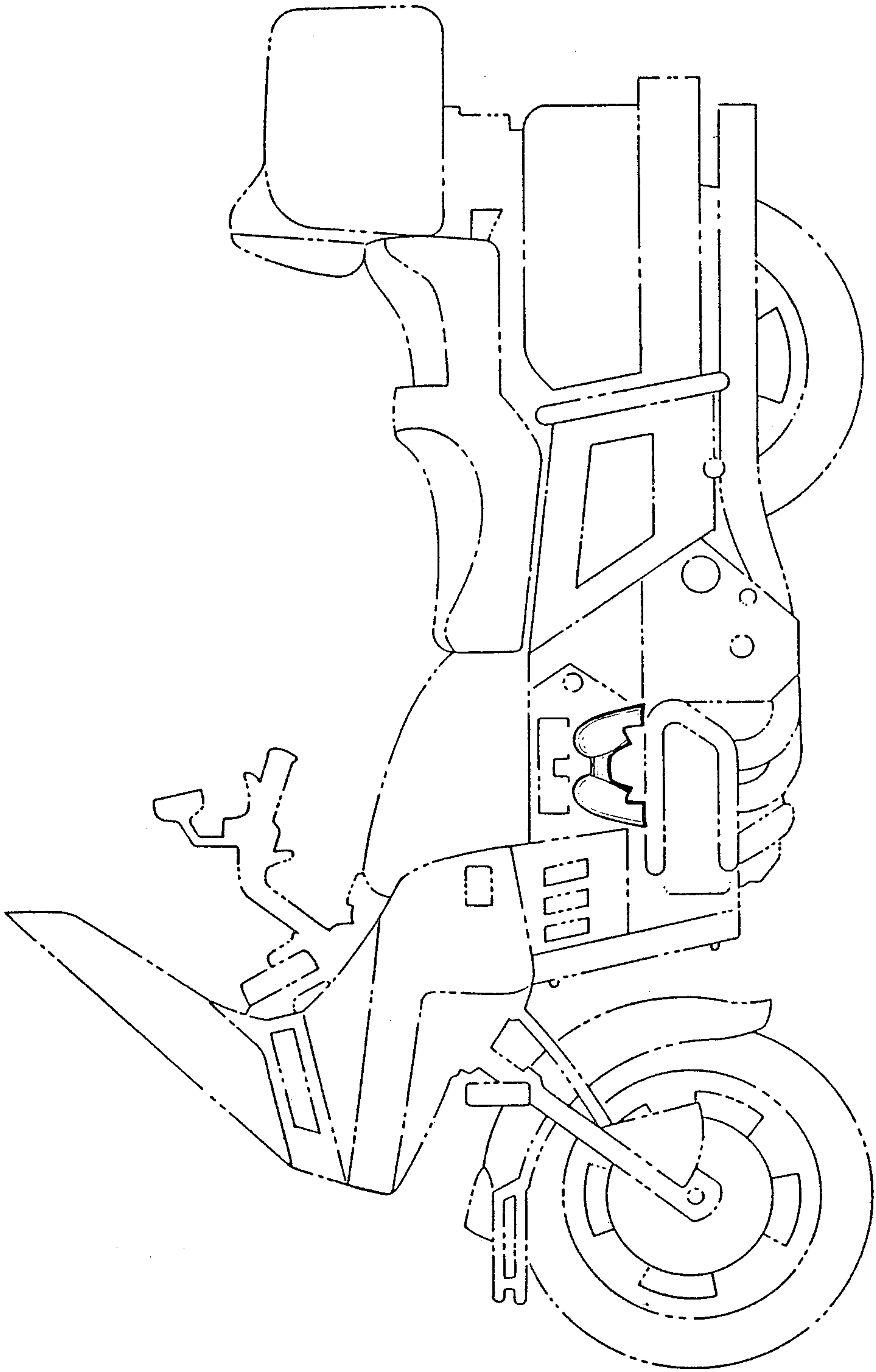

Fig. 2

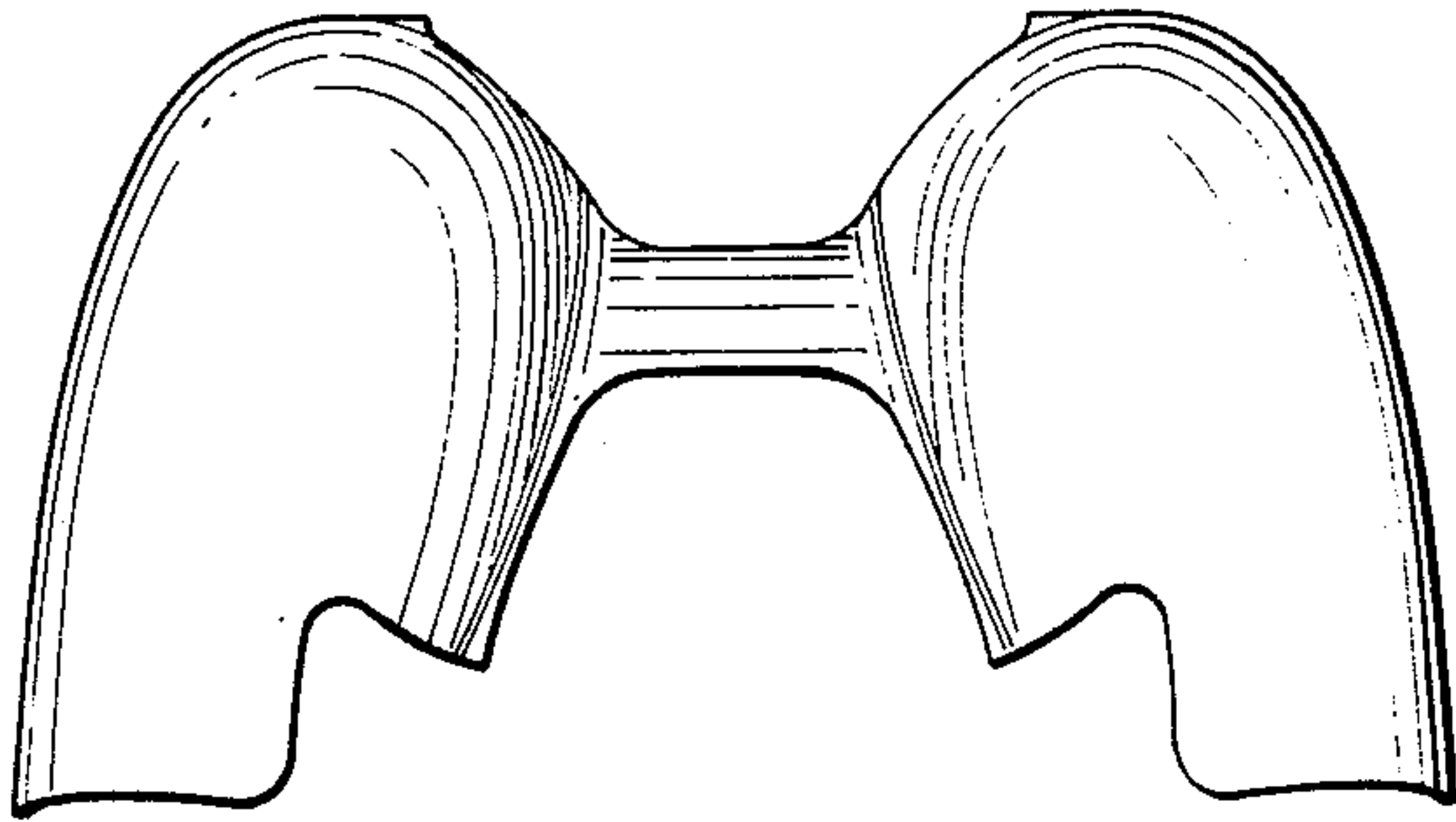

Fig. 3

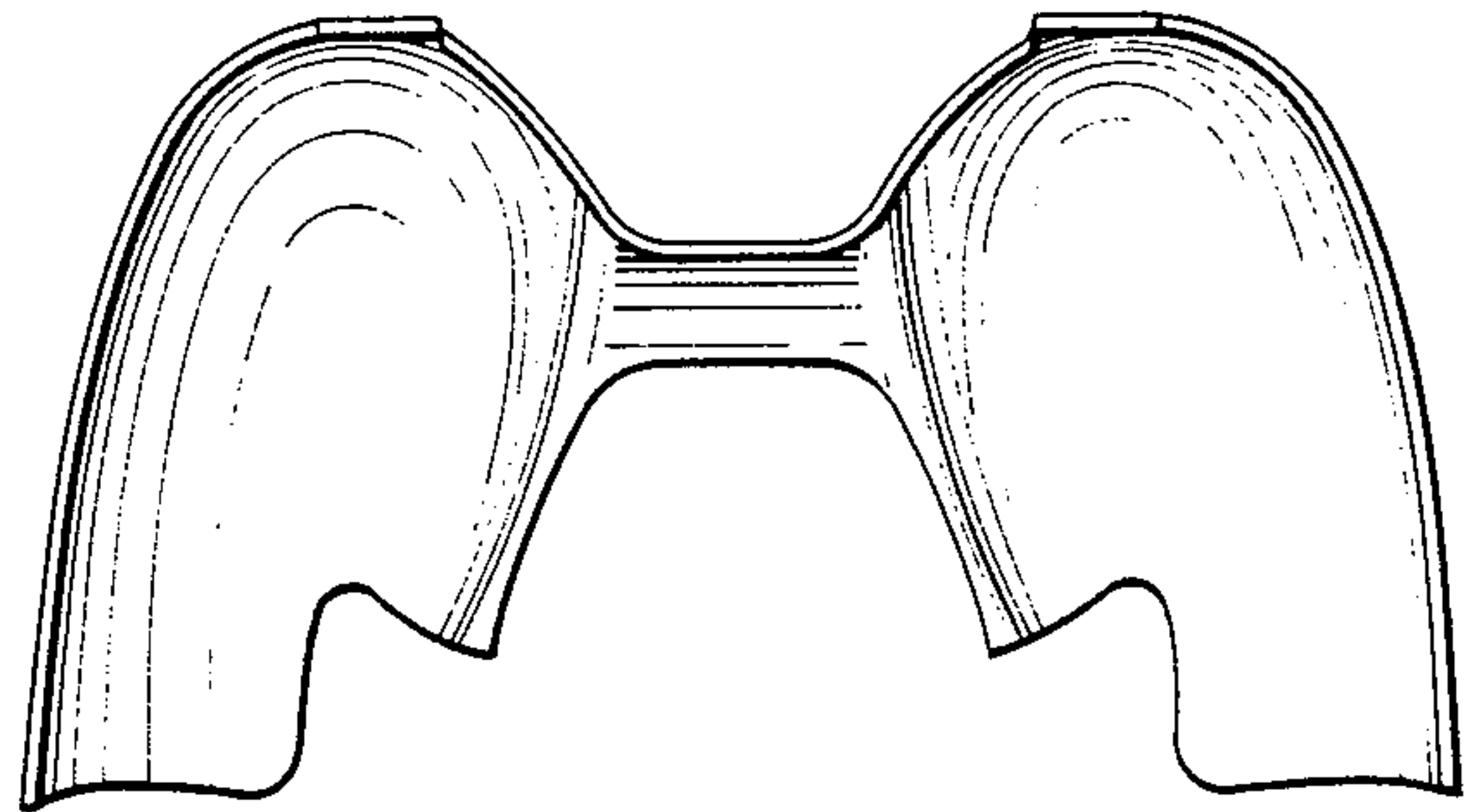

Fig. 5

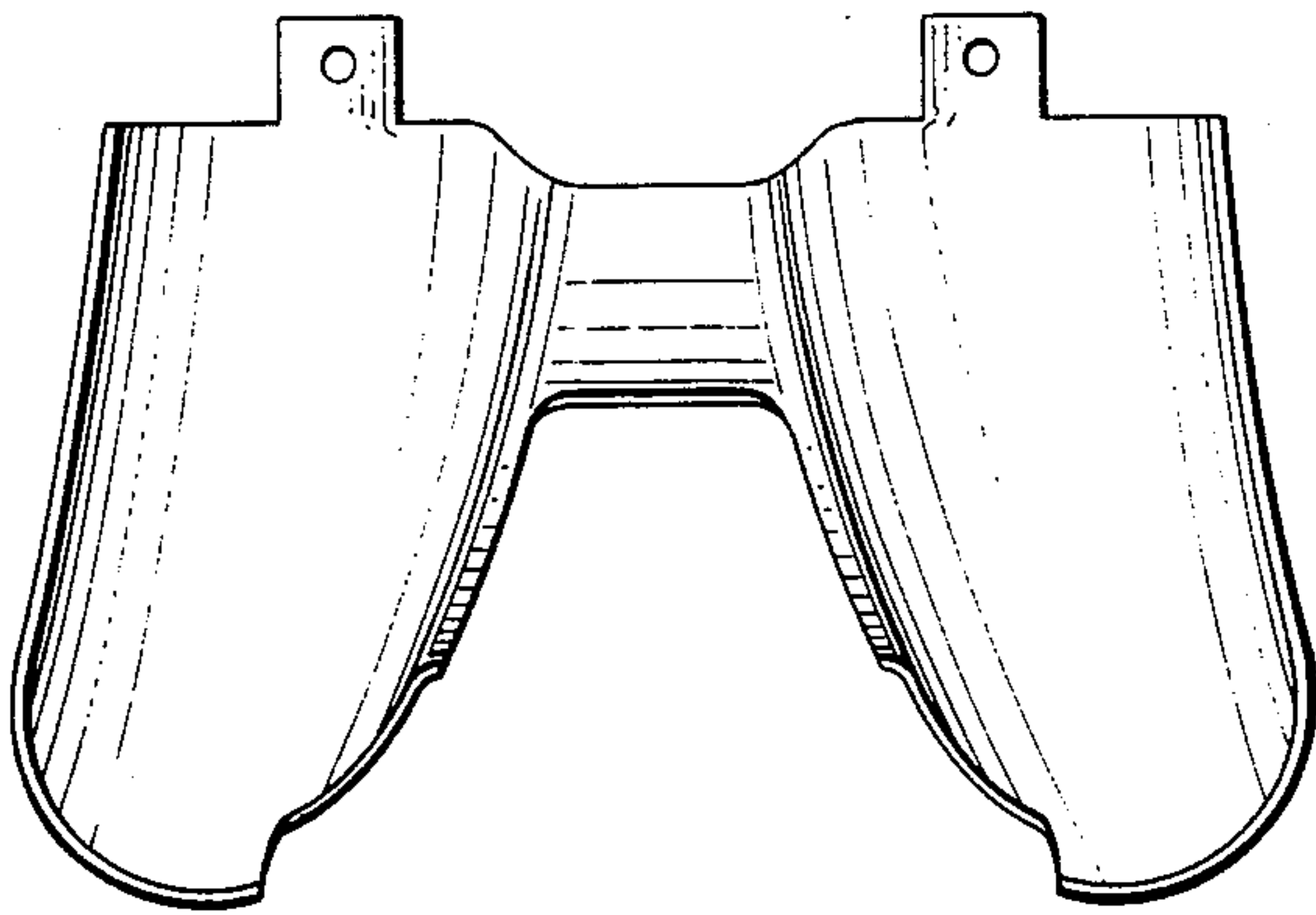

Fig. 4

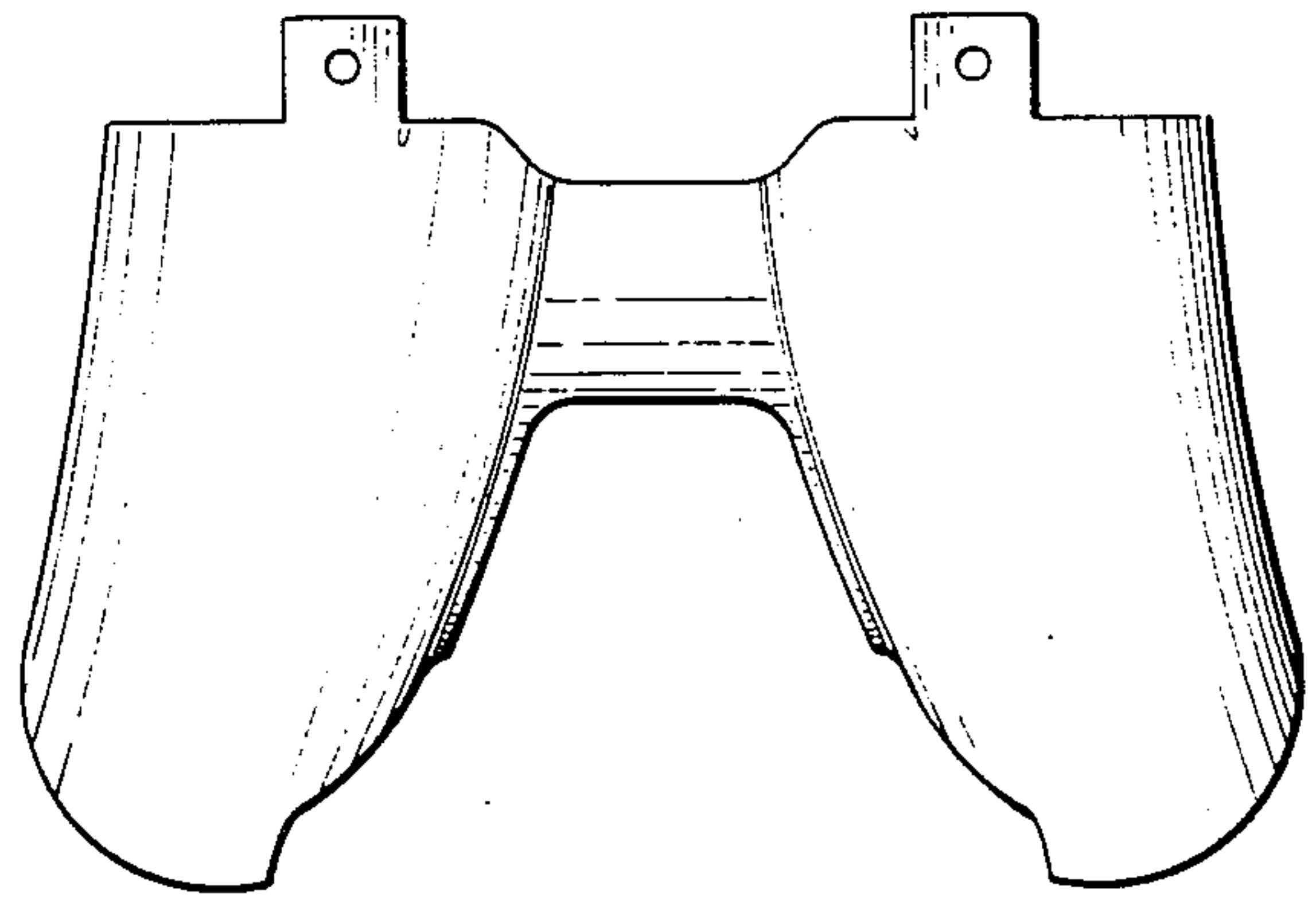

Fig. 6

