

[54] AIRCRAFT PASSENGER SEAT

[75] Inventor: Daniel S. Sauter, Montvale, N.J.

[73] Assignee: Trans World Airlines, Inc., New York, N.Y.

[**] Term: 14 Years

[21] Appl. No.: 492,371

[22] Filed: May 6, 1983

[52] U.S. Cl. D6/356; D6/381

[58] Field of Search D6/334, 356, 360, 361, D6/364, 367, 368, 381; 297/183, 285, 300, 353, 354, 396, 423

[56] References Cited

U.S. PATENT DOCUMENTS

- D. 225,193 11/1972 Barecki D6/356
- D. 249,306 9/1978 Bengtsson D6/367 X

- D. 257,707 12/1980 Marrujo D6/381 X
- D. 267,372 12/1982 Long et al. D6/356
- D. 268,972 5/1983 White D6/356

Primary Examiner—Bruce W. Dunkins
Attorney, Agent, or Firm—Schmidt, Johnson, Hovey & Williams

[57] CLAIM

The ornamental design for an aircraft passenger seat, as shown and described.

DESCRIPTION

FIG. 1 is a front elevational view of the aircraft passenger seat showing my new design;
 FIG. 2 is an elevational view of one end thereof;
 FIG. 3 is an elevational view of the end thereof opposite to that shown in FIG. 2;
 FIG. 4 is a rear elevational view;
 FIG. 5 is a top plan view; and
 FIG. 6 is a bottom plan view.

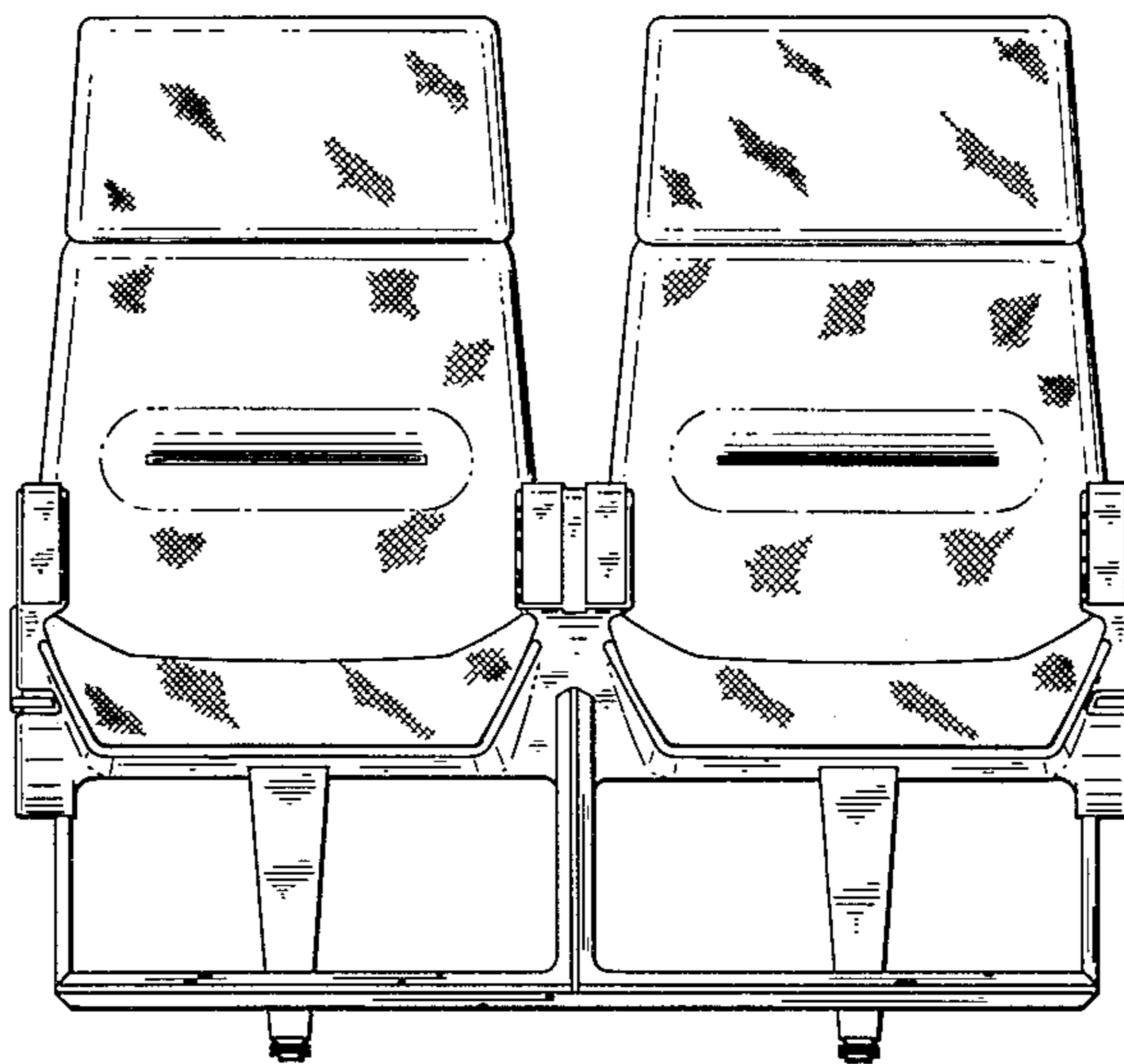

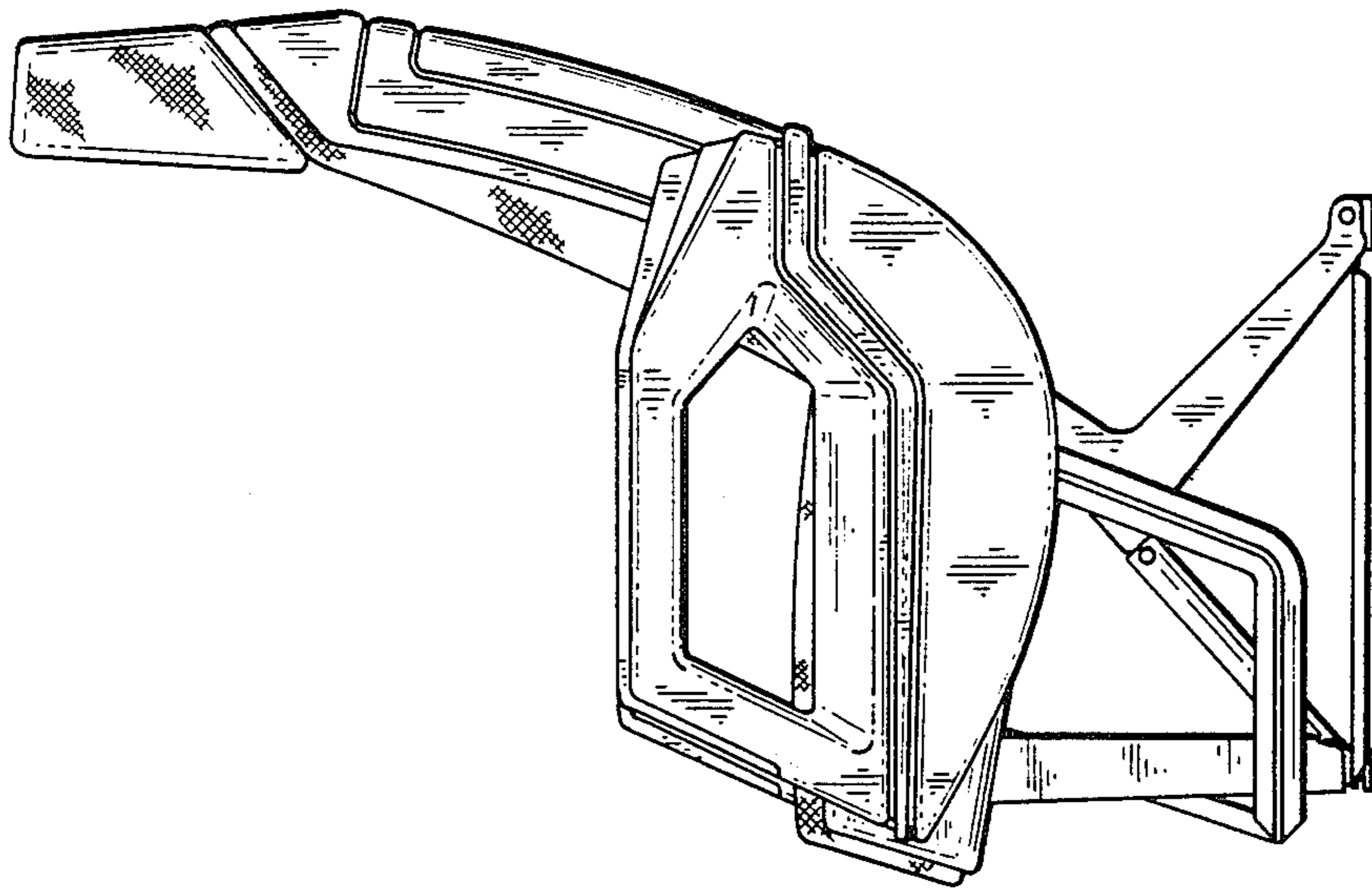

Fig. 2

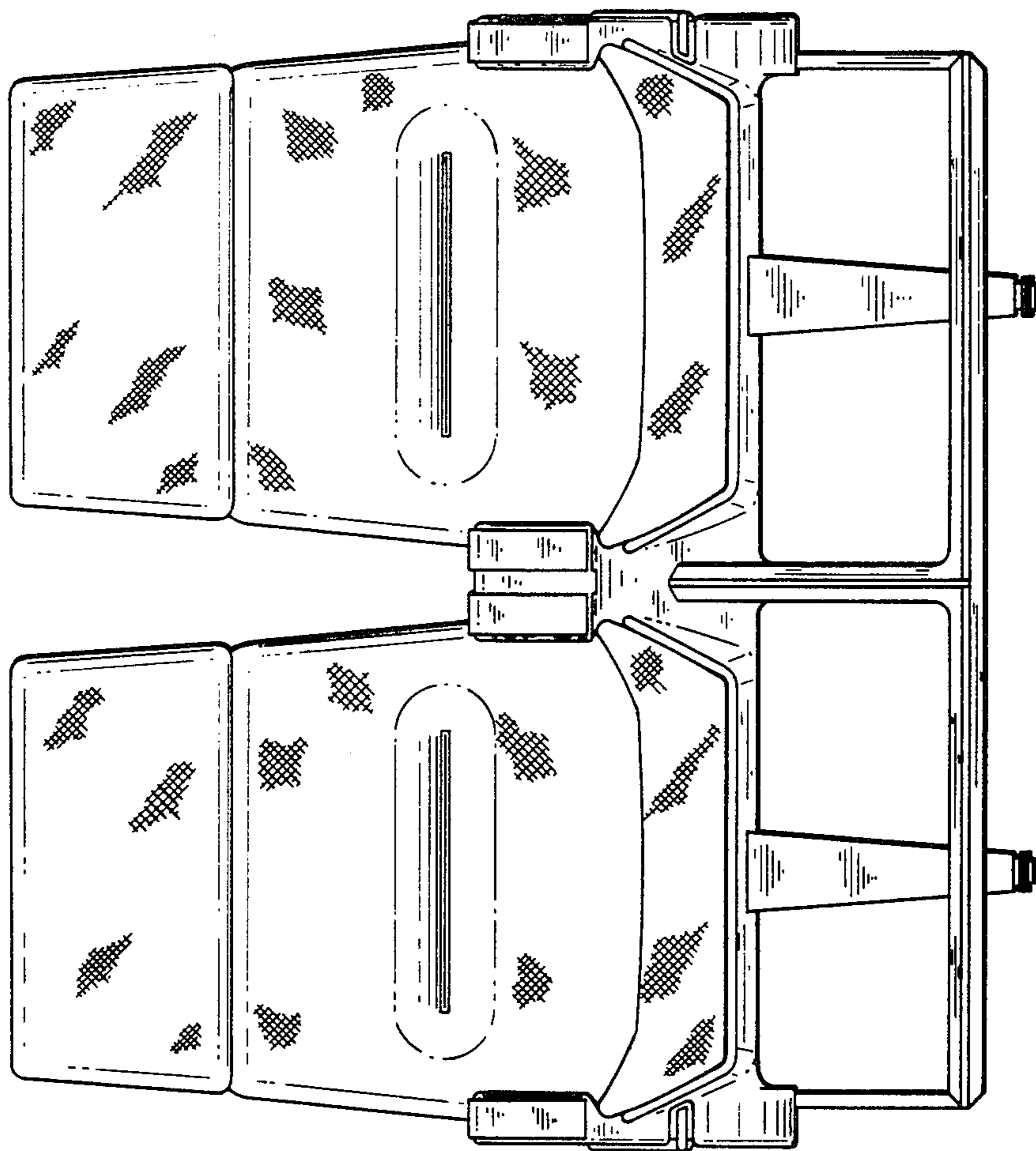

Fig. 1

Fig. 4

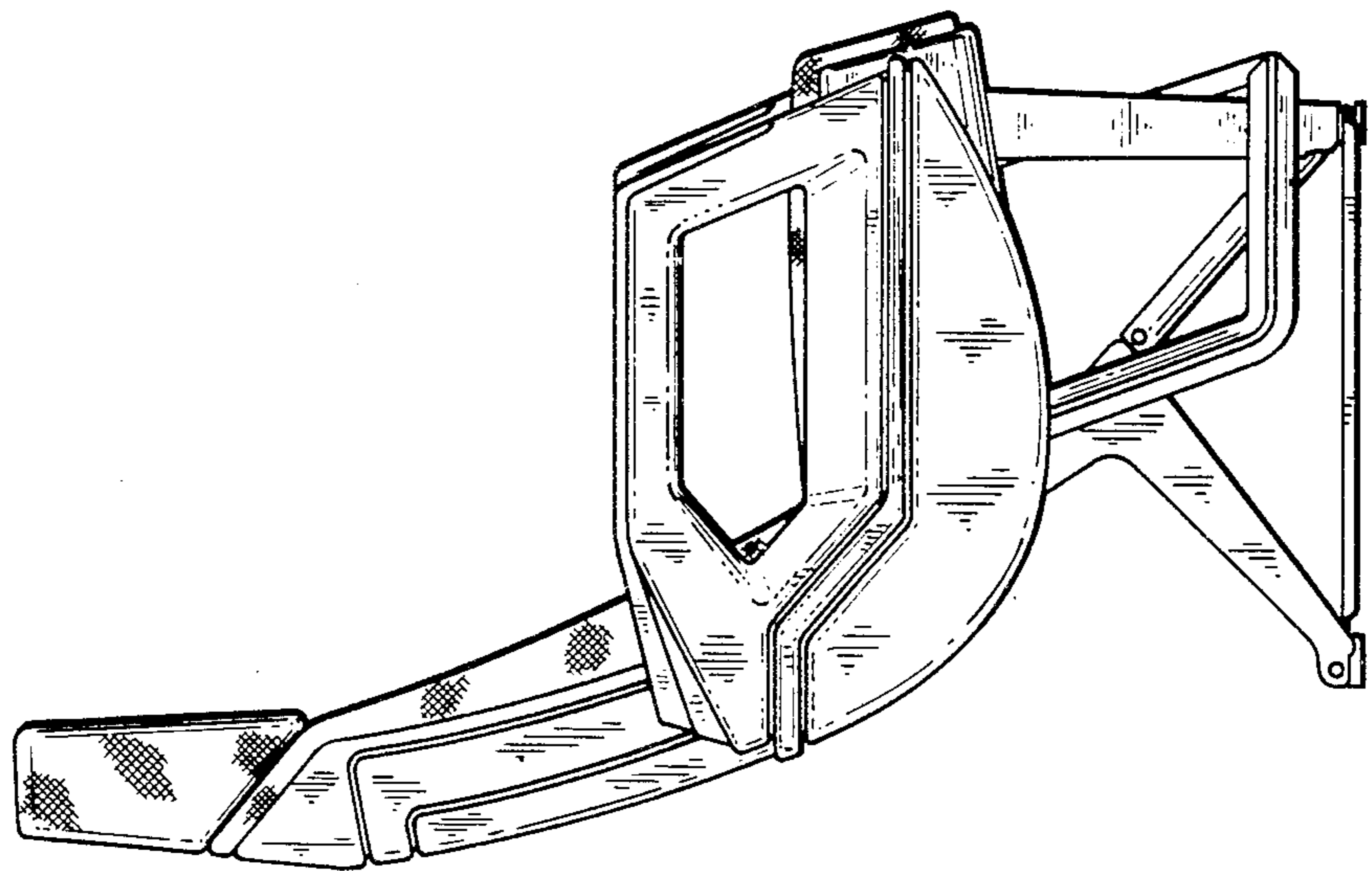
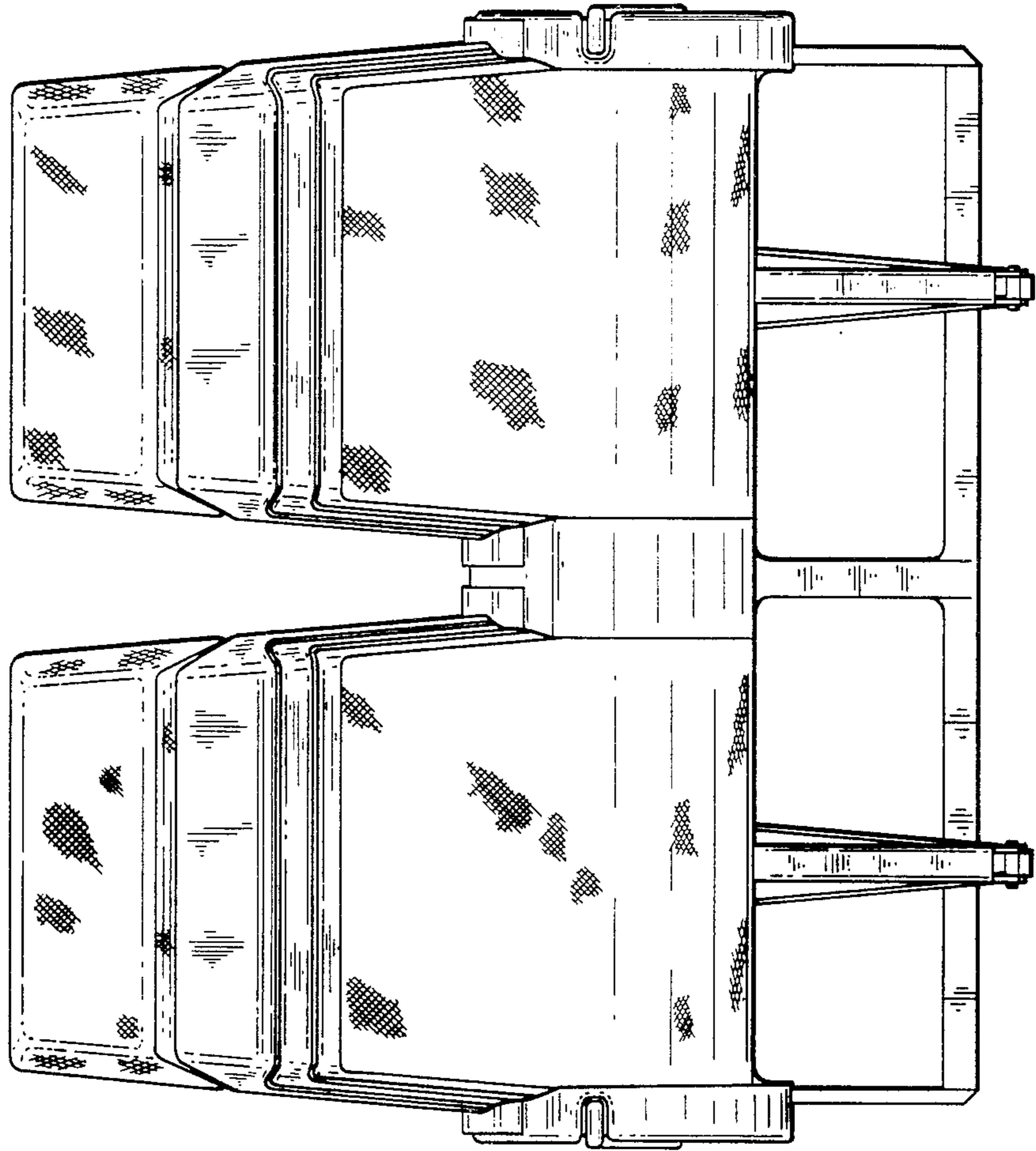

Fig. 3



Fig. 5

Fig. 6

