

- [54] **AUTOMATED TELEPHONE COMMUNICATING MACHINE**
- [75] Inventors: **Charles L. Meininger**, Littleton, Colo.; **Robert S. Bugash**, Wheaton, Md.
- [73] Assignee: **Applied Computer, Inc.**, Denver, Colo.
- [**] Term: **14 Years**
- [21] Appl. No.: **426,803**
- [22] Filed: **Sep. 29, 1982**
- [52] U.S. Cl. **D14/52; D14/53; D14/59; D14/4; D14/102**
- [58] Field of Search **D14/52, 4, 53, 100, D14/59, 58, 60, 92, 102, 106; 179/6.1, 6.09, 6.07, 6.11; D13/12, 32, 35**

[56] **References Cited**
U.S. PATENT DOCUMENTS

D. 197,229	12/1963	Michael	D13/12
D. 213,372	2/1969	Gross	D13/12
D. 223,496	4/1972	Forosta	D14/4
D. 231,464	4/1974	Dalke	D14/100
D. 257,588	12/1980	Cadotta et al.	D14/100
D. 262,287	12/1981	Urbanus et al.	D14/100
D. 273,109	3/1984	Breger	D14/58
D. 273,487	4/1984	Rosenbaum	D13/12
3,757,049	9/1973	Bonsky et al.	179/6.11
3,808,372	4/1974	Sielsch	179/6.01
4,178,477	12/1979	Sato	179/6.01

FOREIGN PATENT DOCUMENTS

3003554	8/1981	Fed. Rep. of Germany	D14/53
		UX		

Primary Examiner—A. Hugo Word

Assistant Examiner—Horace B. Fay
 Attorney, Agent, or Firm—John R. Ley

[57] **CLAIM**

The ornamental design for an automated telephone communicating machine, as shown and described.

DESCRIPTION

FIG. 1 is a perspective view of an automated telephone communicating machine embodying the present design in two components, a first component and a second component, the first component being shown resting on top of the second component.

FIG. 2 is a perspective view only of the first component thereof.

FIG. 3 is a top plan view of the first component thereof.

FIG. 4 is a front elevational view of the first component thereof.

FIG. 5 is a bottom plan view of the first component thereof.

FIG. 6 is a right-hand side elevational view of the first component thereof, the left-hand side elevational view being a mirror image thereof.

FIG. 7 is a back elevational view of the first component thereof.

FIG. 8 is a perspective view of only the second component thereof.

FIG. 9 is a top plan view of the second component thereof.

FIG. 10 is a front elevational view of the second component thereof.

FIG. 11 is a bottom plan view of the second component thereof.

FIG. 12 is a rear elevational view of the second component thereof.

FIG. 13 is a right-hand elevational view of the second component thereof, the left-hand side elevational view being a mirror image thereof.

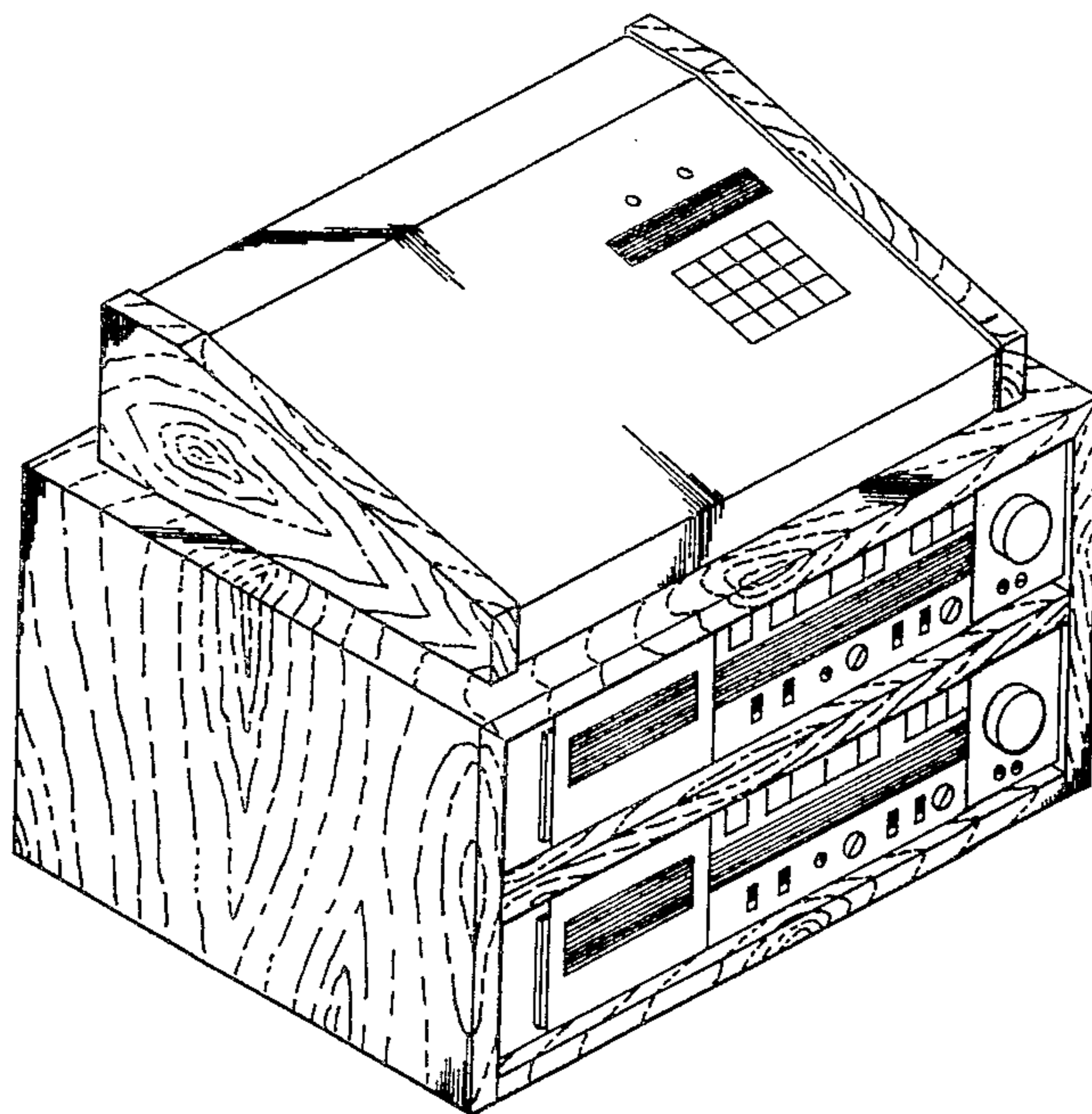

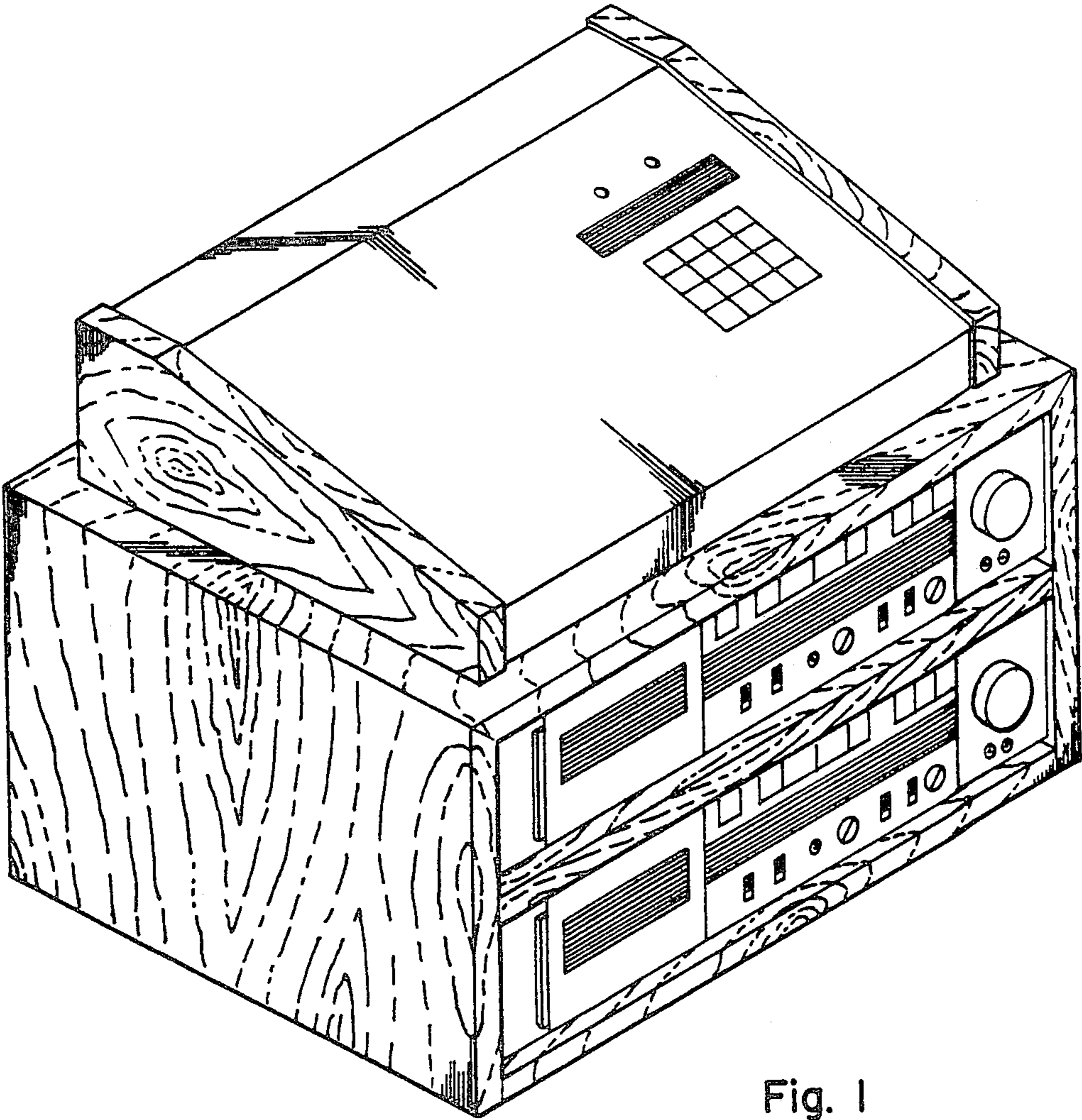

Fig. 1

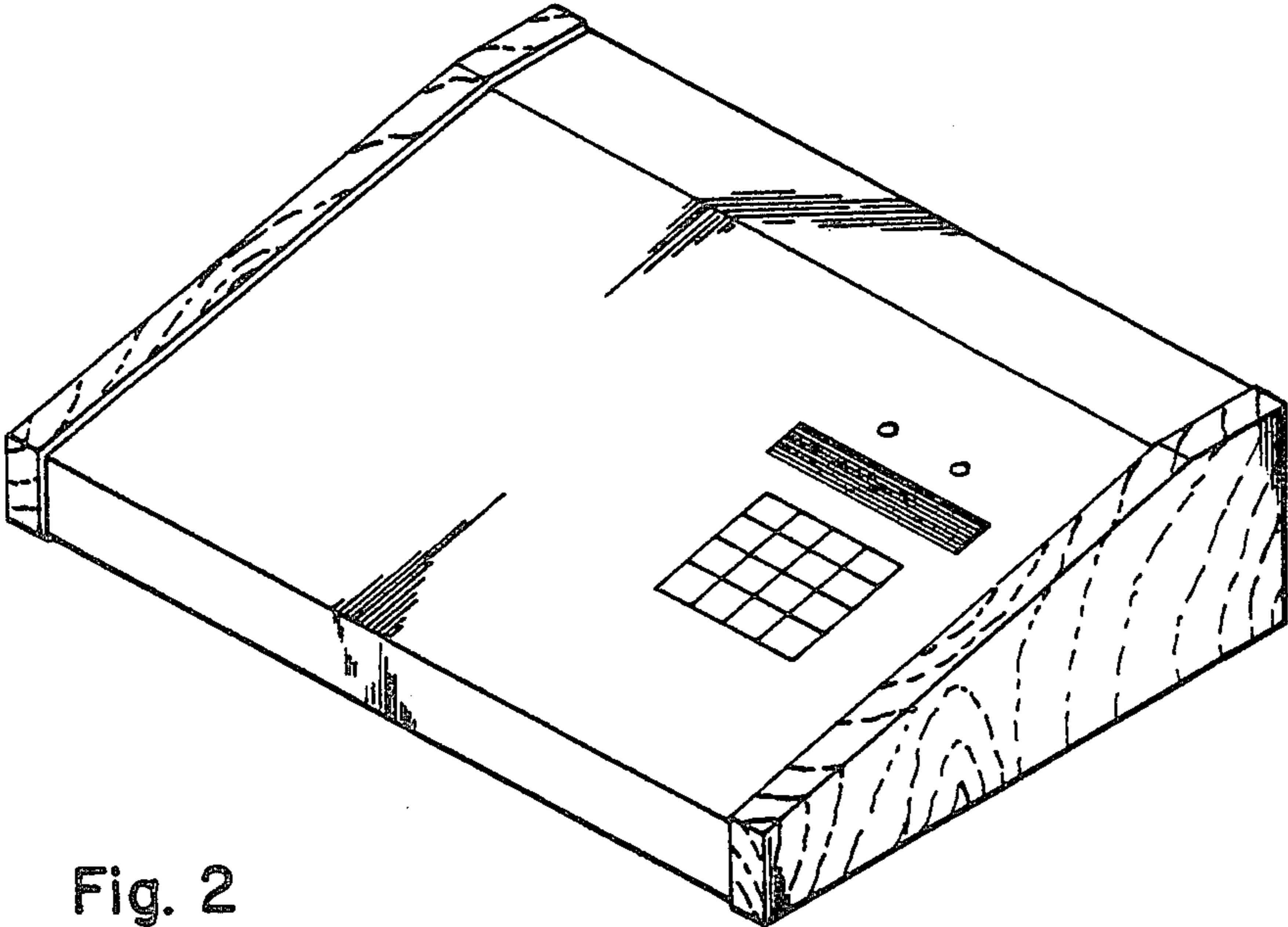

Fig. 2

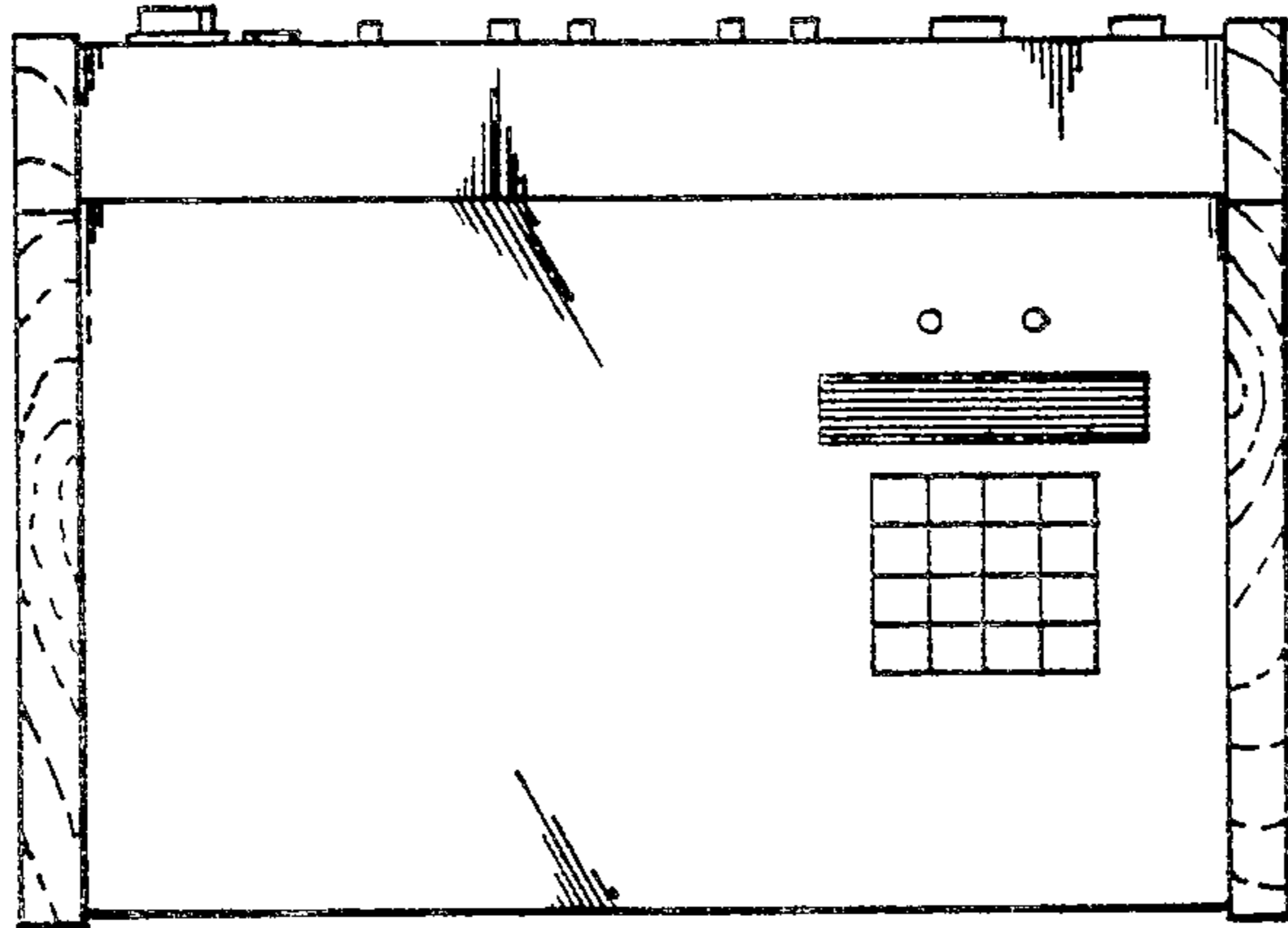

Fig. 3

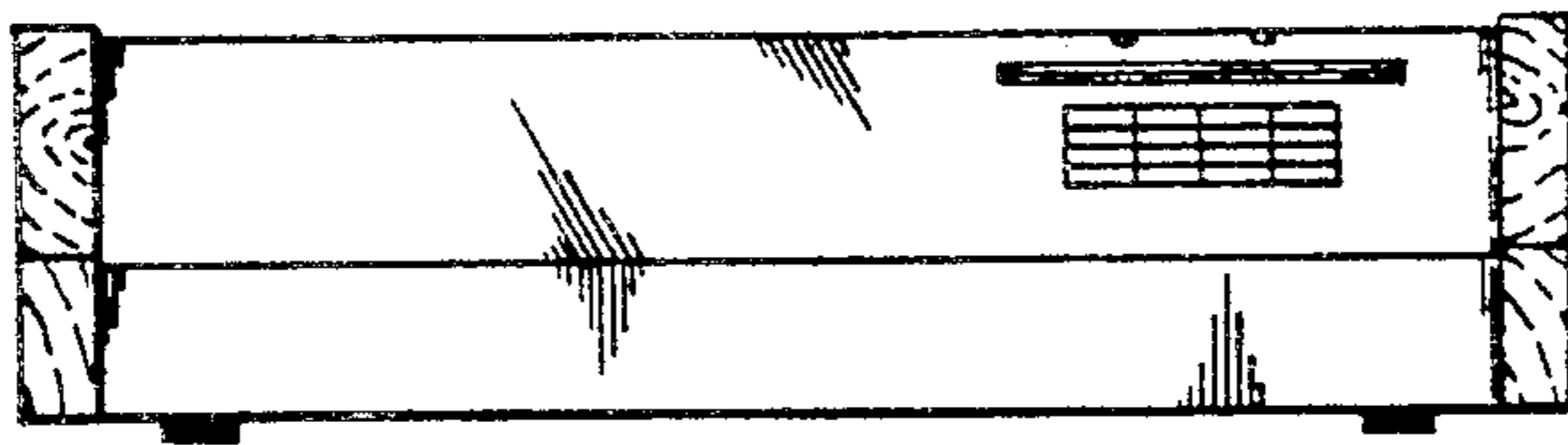

Fig. 4

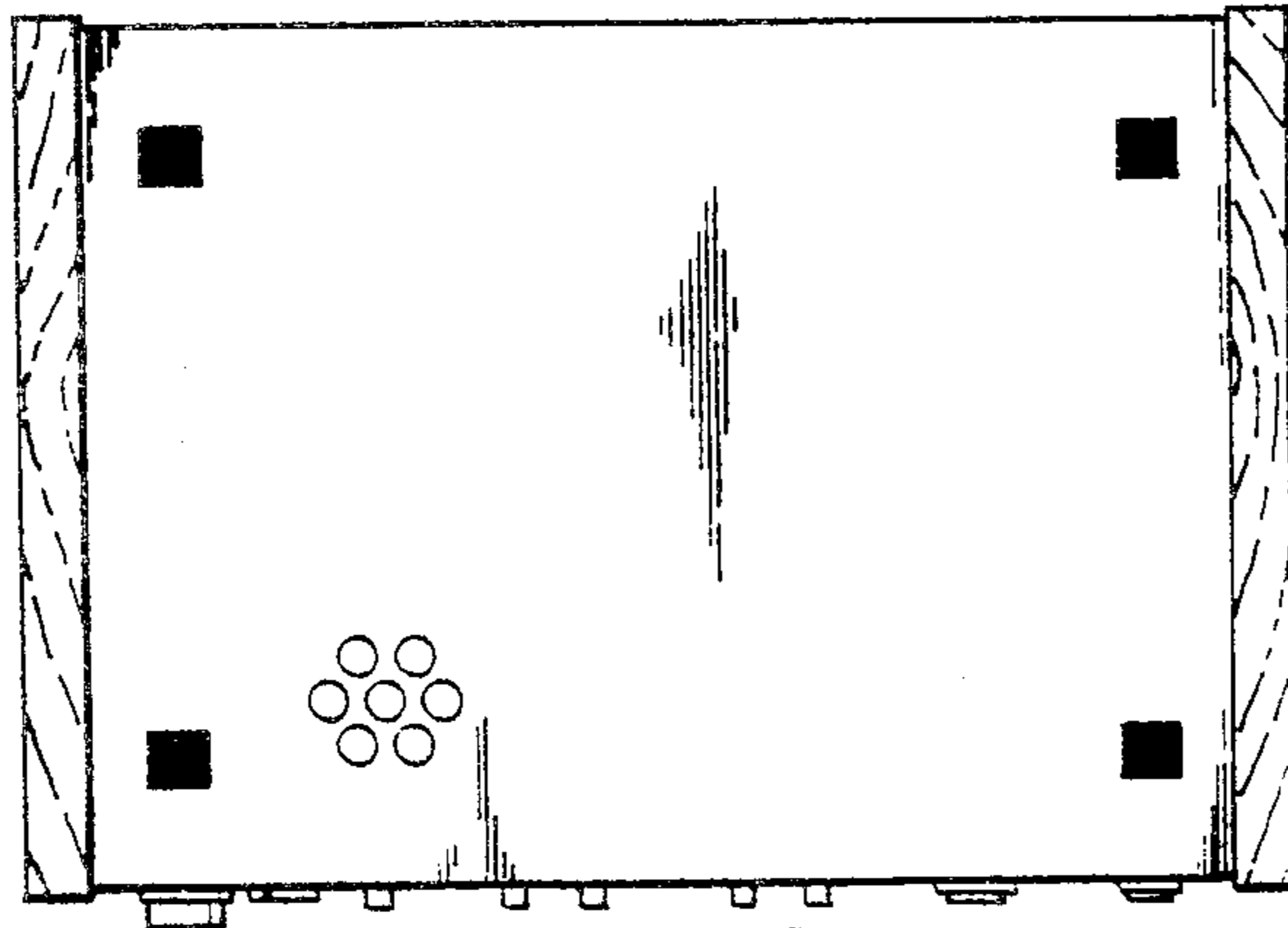

Fig. 5

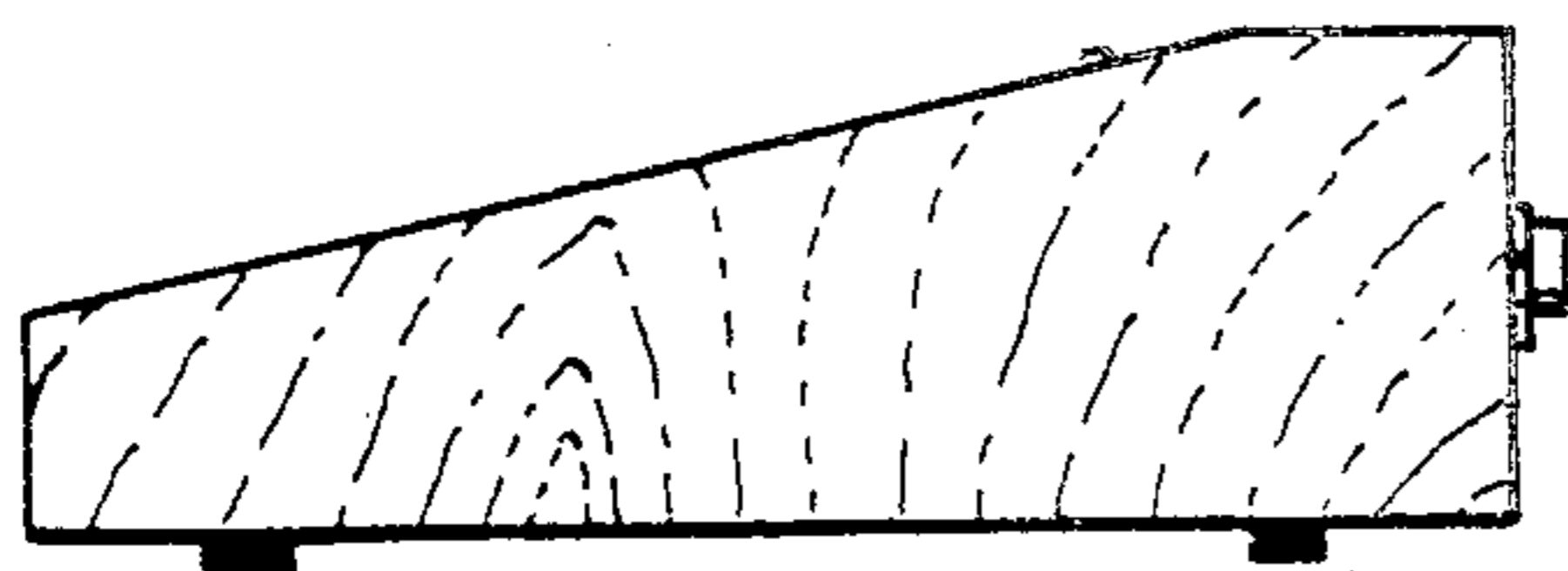

Fig. 6

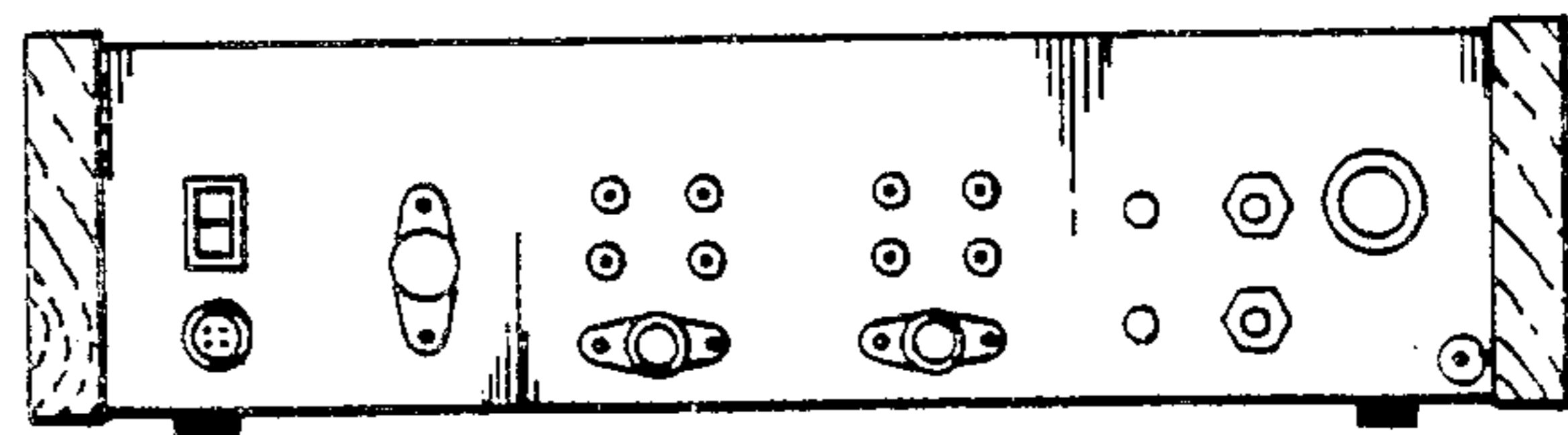

Fig. 7

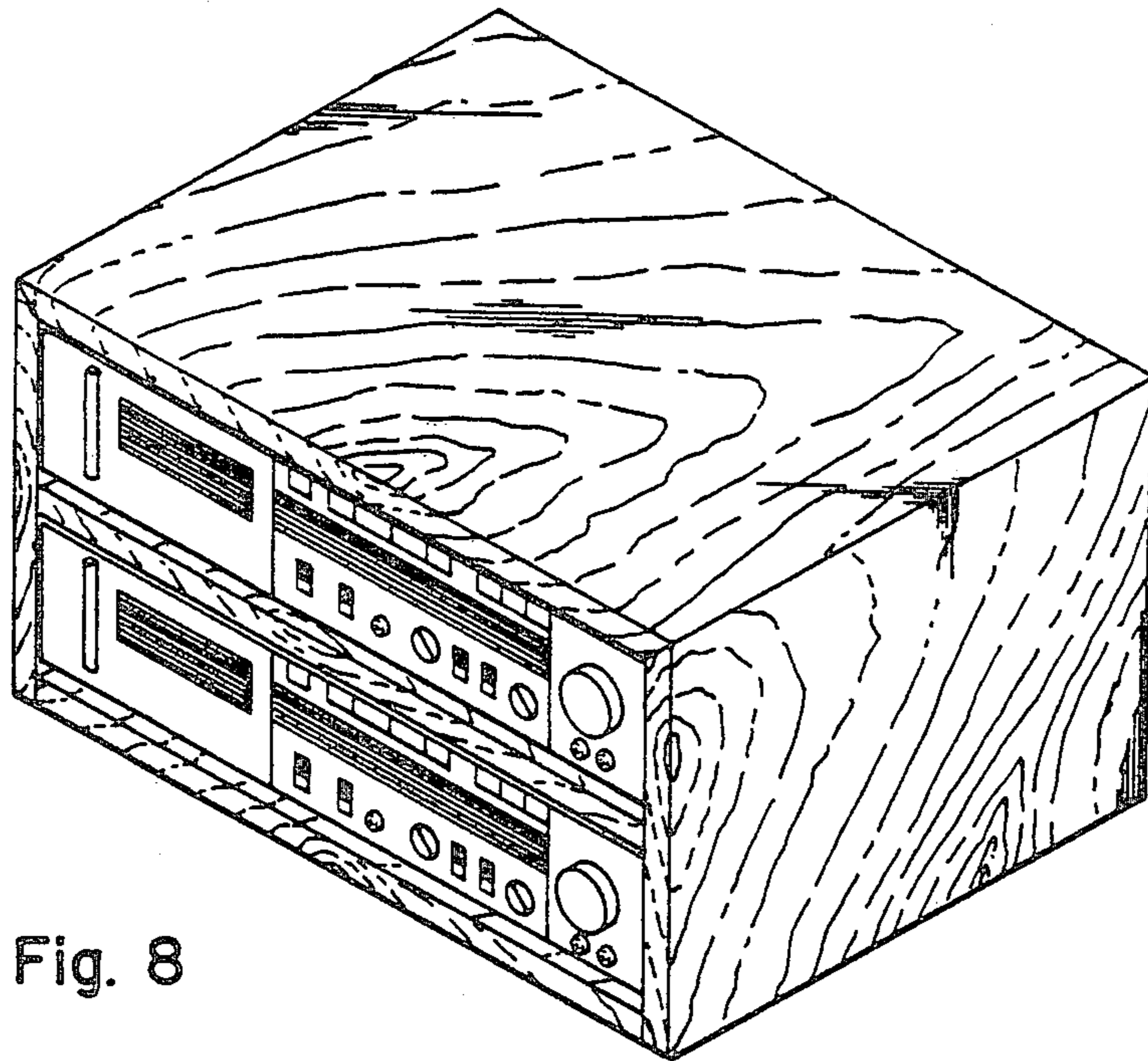

Fig. 8

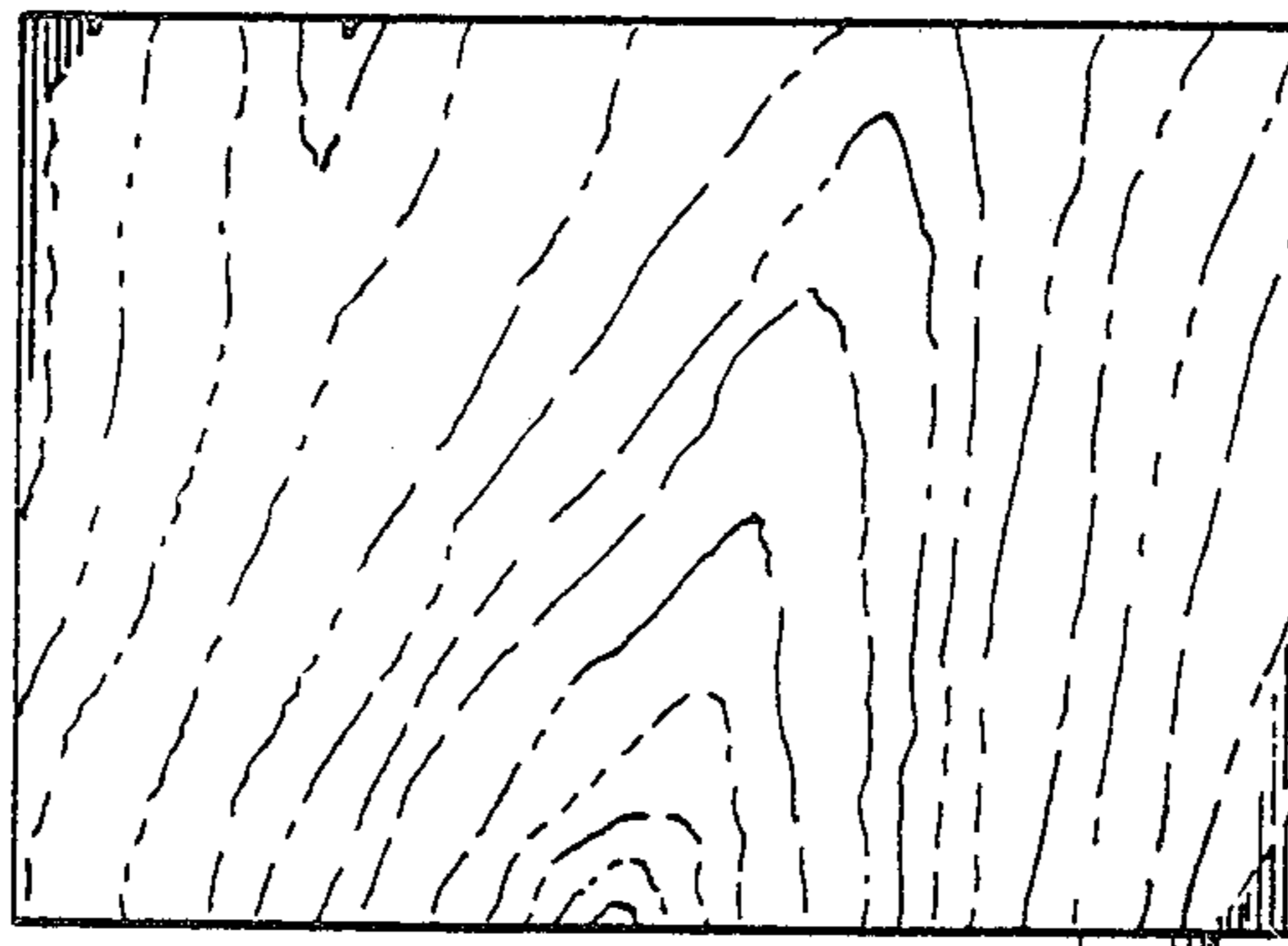

Fig. 9

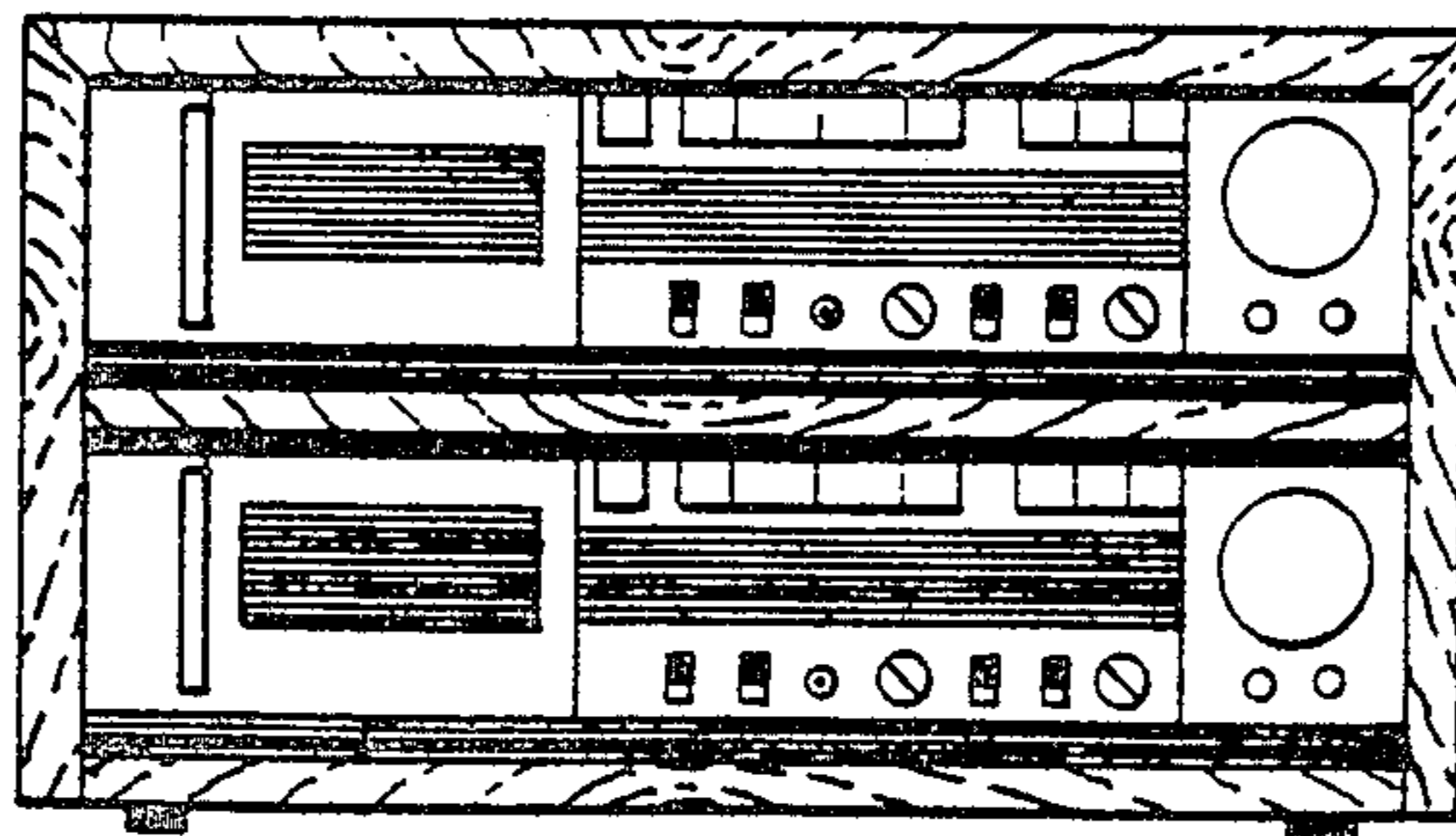

Fig. 10

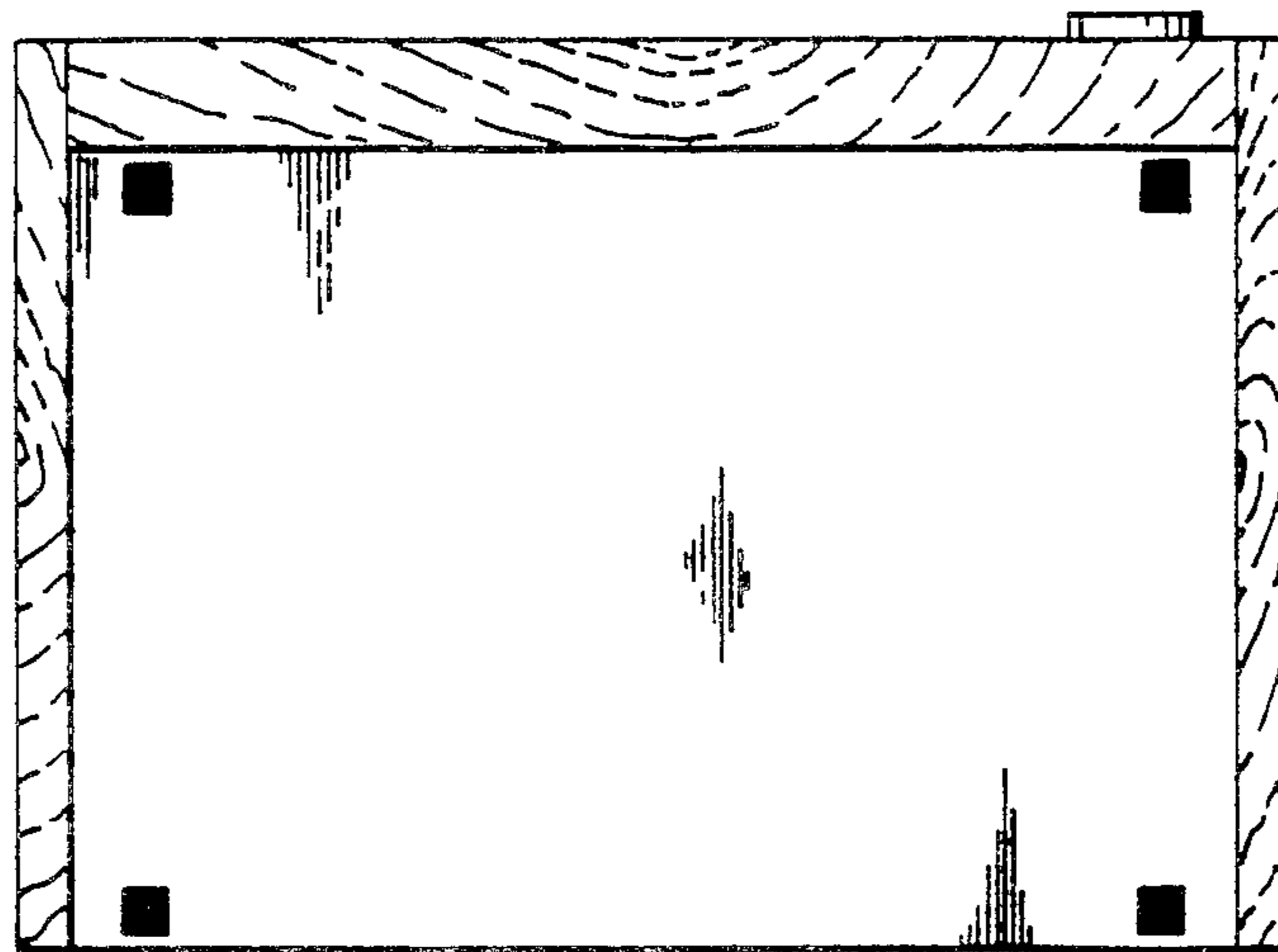

Fig. 11

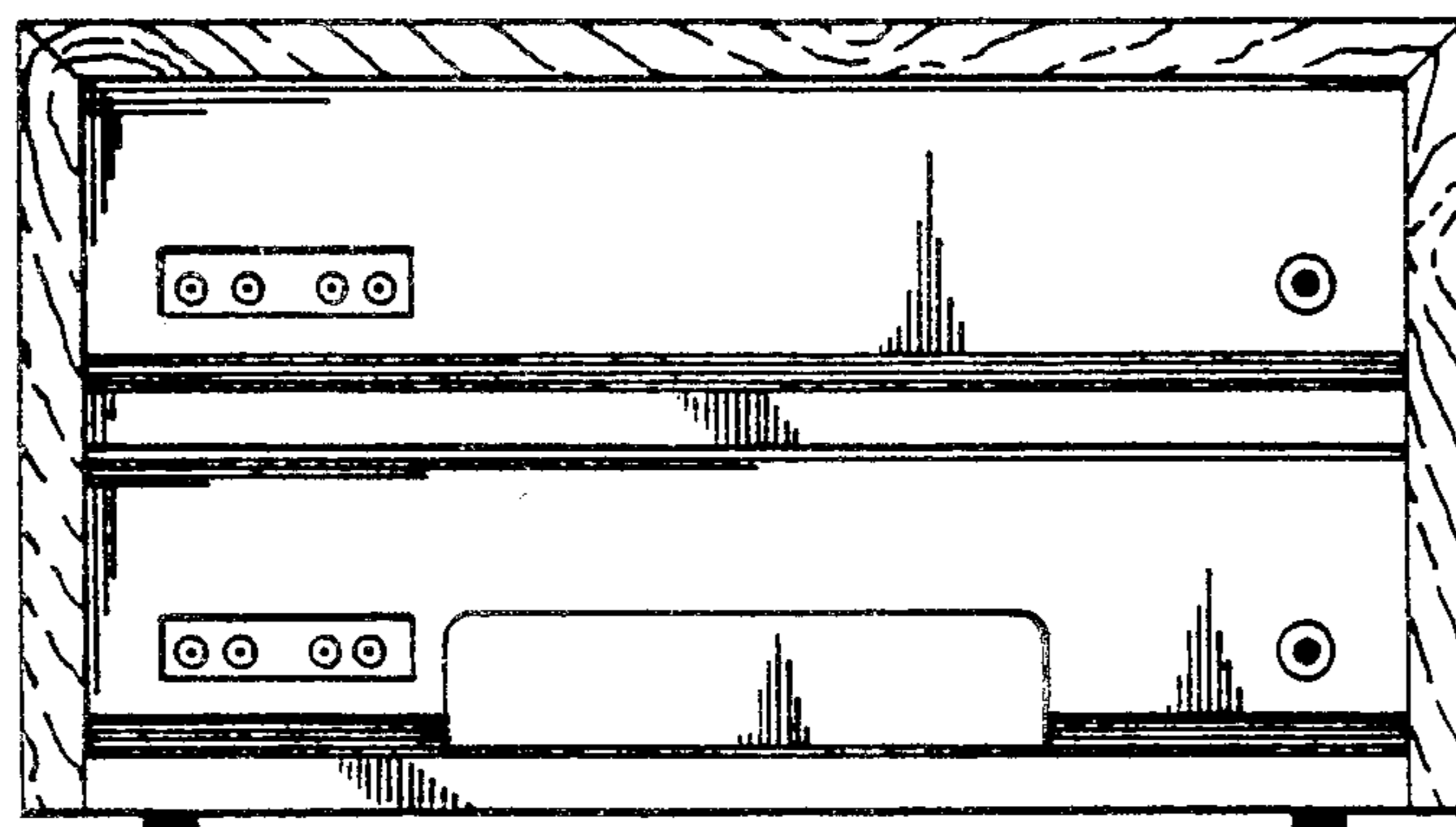

Fig. 12

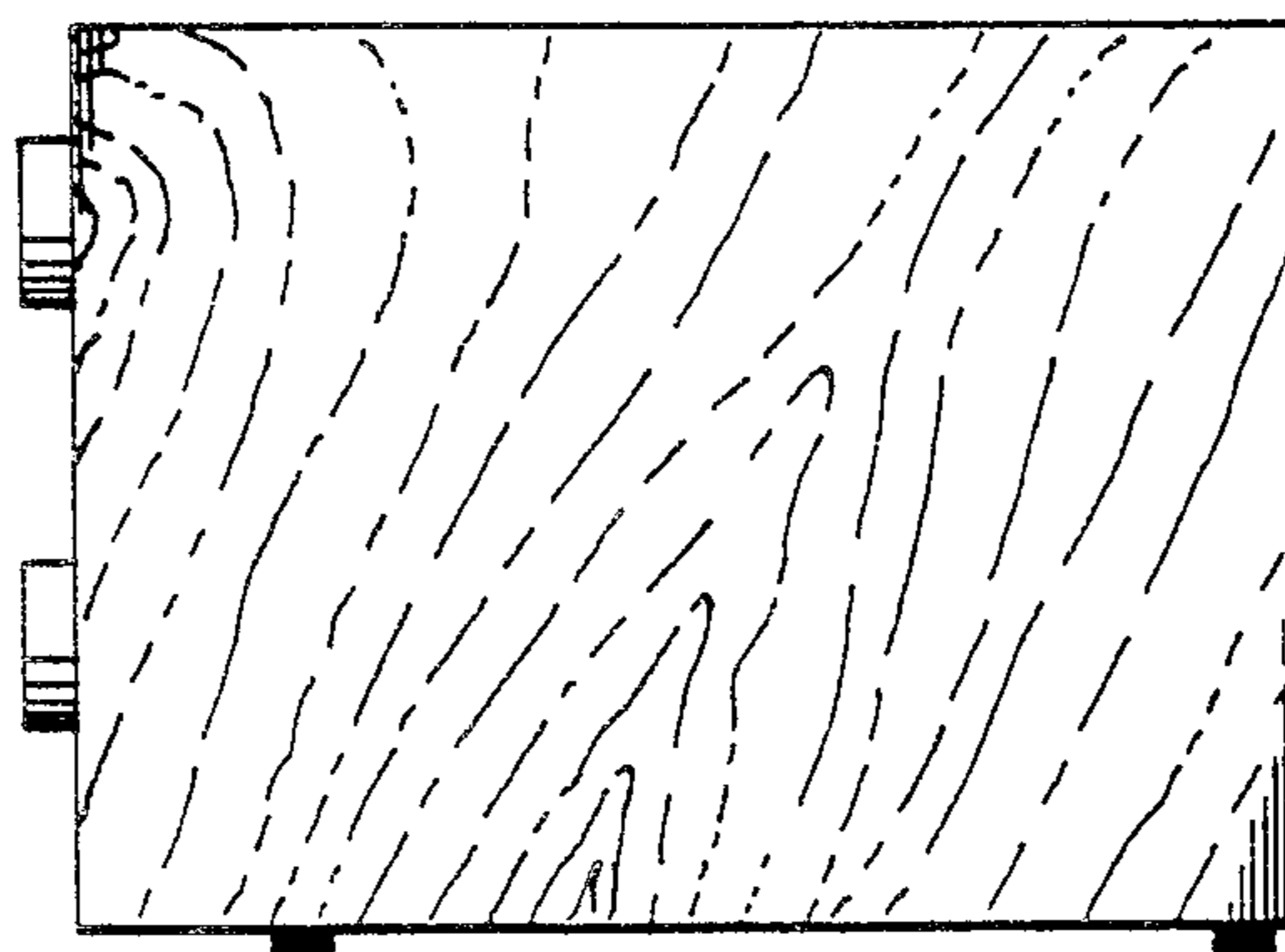

Fig. 13