

[54] **ADJUSTABLE BOX WRENCH**

[76] **Inventor:** **Hin C. Lok**, B1, Earl St., Earl Garden, Kowloon, Hong Kong

[\*\*] **Term:** **14 Years**

[21] **Appl. No.:** **460,400**

[22] **Filed:** **Jan. 24, 1983**

[30] **Foreign Application Priority Data**

Sep. 1, 1982 [GB] United Kingdom ..... 1008507

[52] **U.S. Cl.** ..... **D8/22; D8/28**

[58] **Field of Search** ..... **D8/17, 18, 19, 20-29; 81/173, 174, 176, 90 B, 125.1**

[56] **References Cited**

**U.S. PATENT DOCUMENTS**

843,274	2/1907	Hughes	81/90 B
1,280,802	10/1918	Miller	81/173 X
2,591,788	4/1952	Day	81/125.1 X
2,754,710	7/1956	Cullen	81/174

**OTHER PUBLICATIONS**

The Antique Wrench Book by Wullweber ©1982, p. 71, (second box down from top on right).

*Primary Examiner*—Susan J. Lucas

*Assistant Examiner*—C. E. Heflin

*Attorney, Agent, or Firm*—Bacon & Thomas

[57] **CLAIM**

The ornamental design for an adjustable box wrench, substantially as shown.

**DESCRIPTION**

FIG. 1 is a perspective view of an adjustable box wrench showing my new design;  
FIG. 2 is a top plan view thereof;  
FIG. 3 is a right end elevational view thereof;  
FIG. 4 is a left end elevational view thereof;  
FIG. 5 is a side elevational view thereof of the side opposite that shown in FIG. 1;  
FIG. 6 is a perspective view thereof with the locking ring shown in the released position.

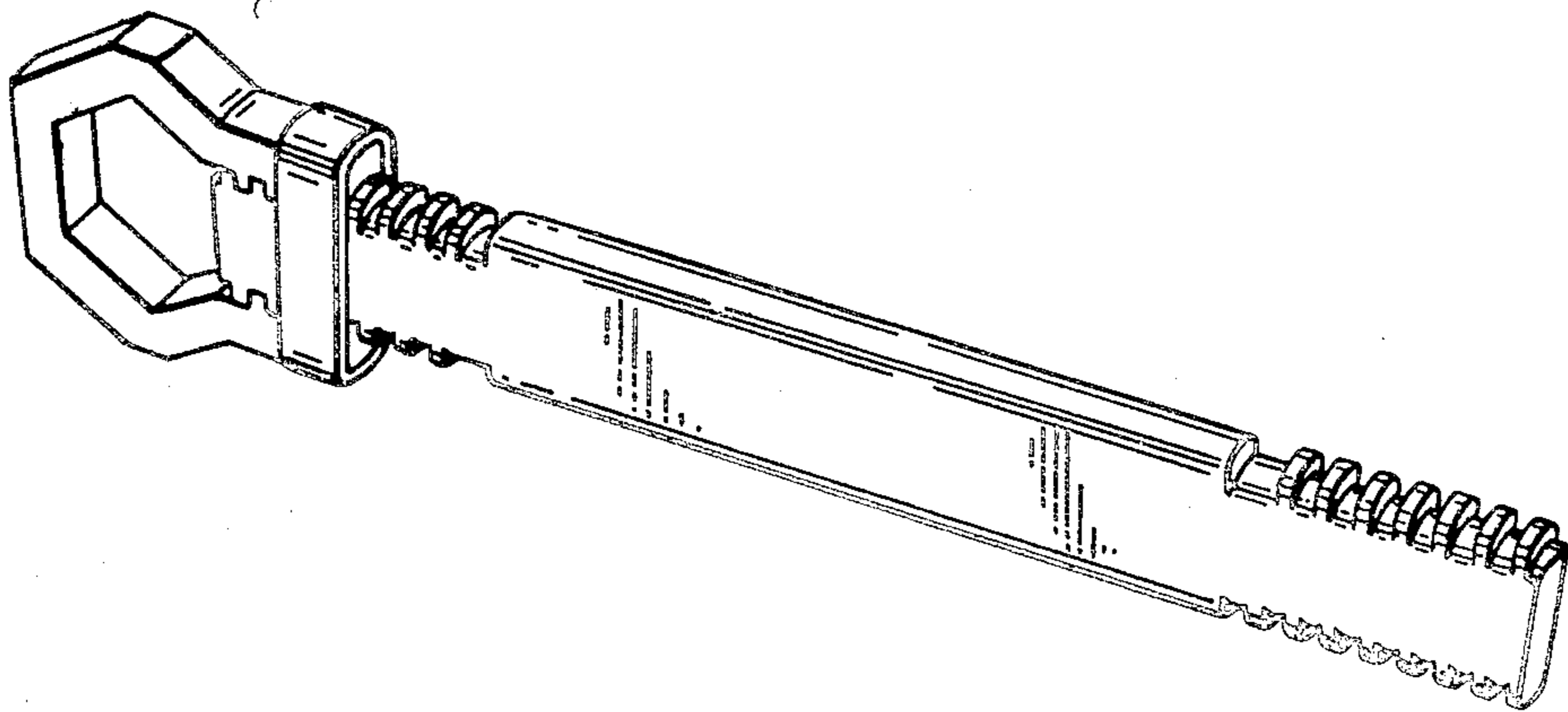

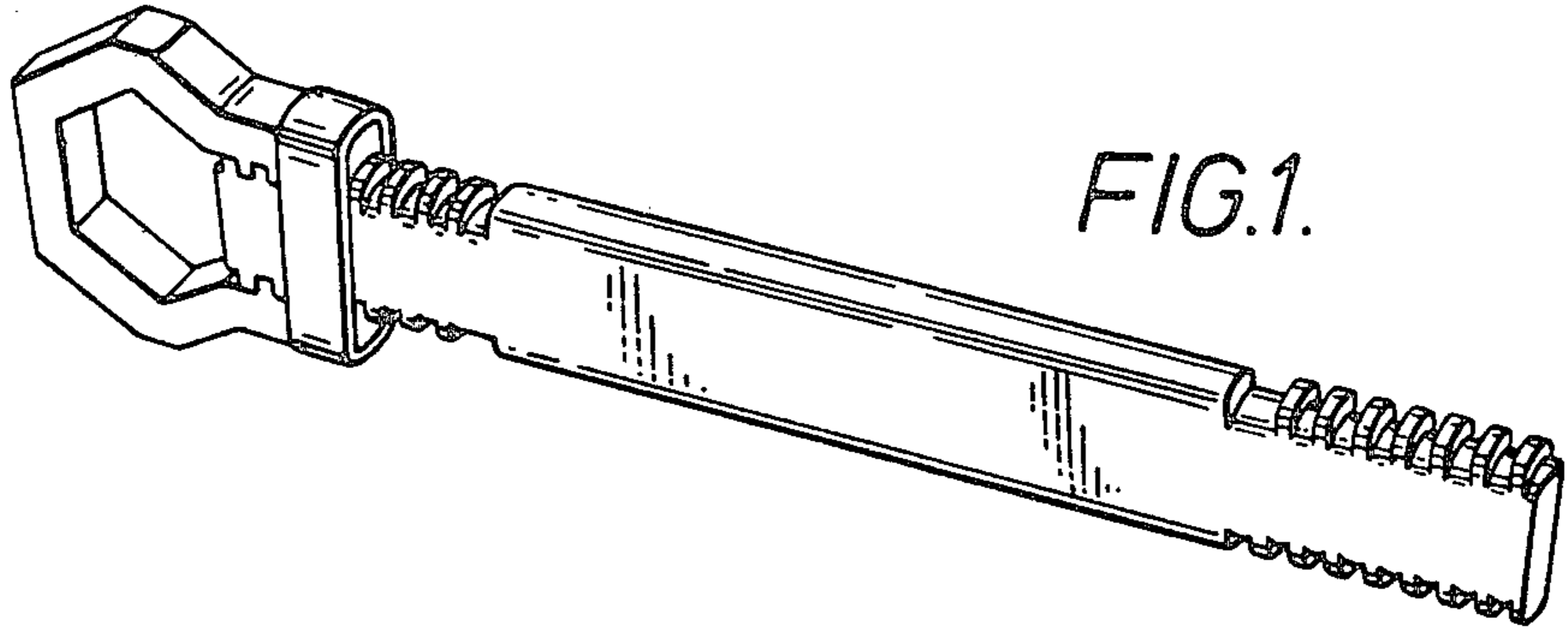

FIG. 1.

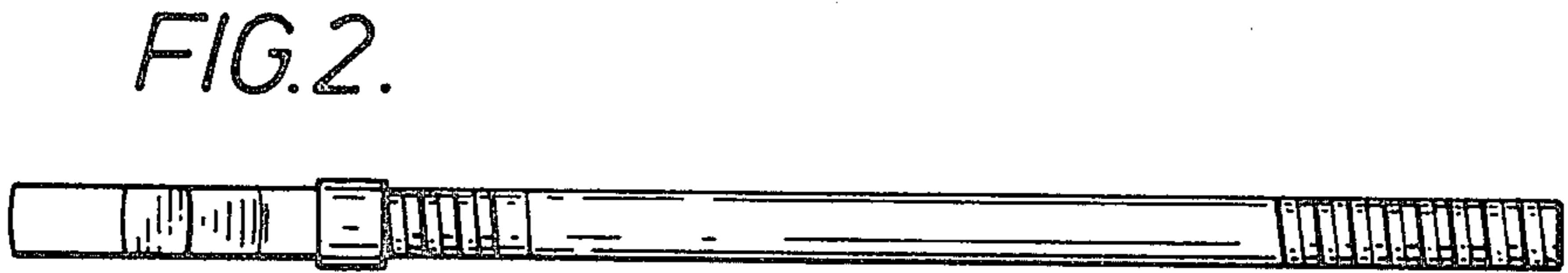

FIG. 2.



FIG. 3.



FIG. 4.

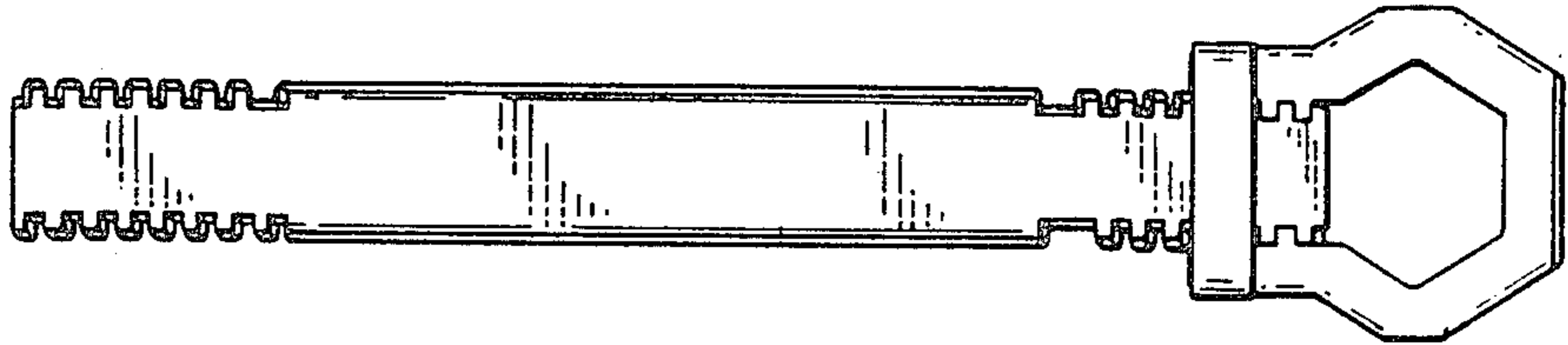

FIG. 5.

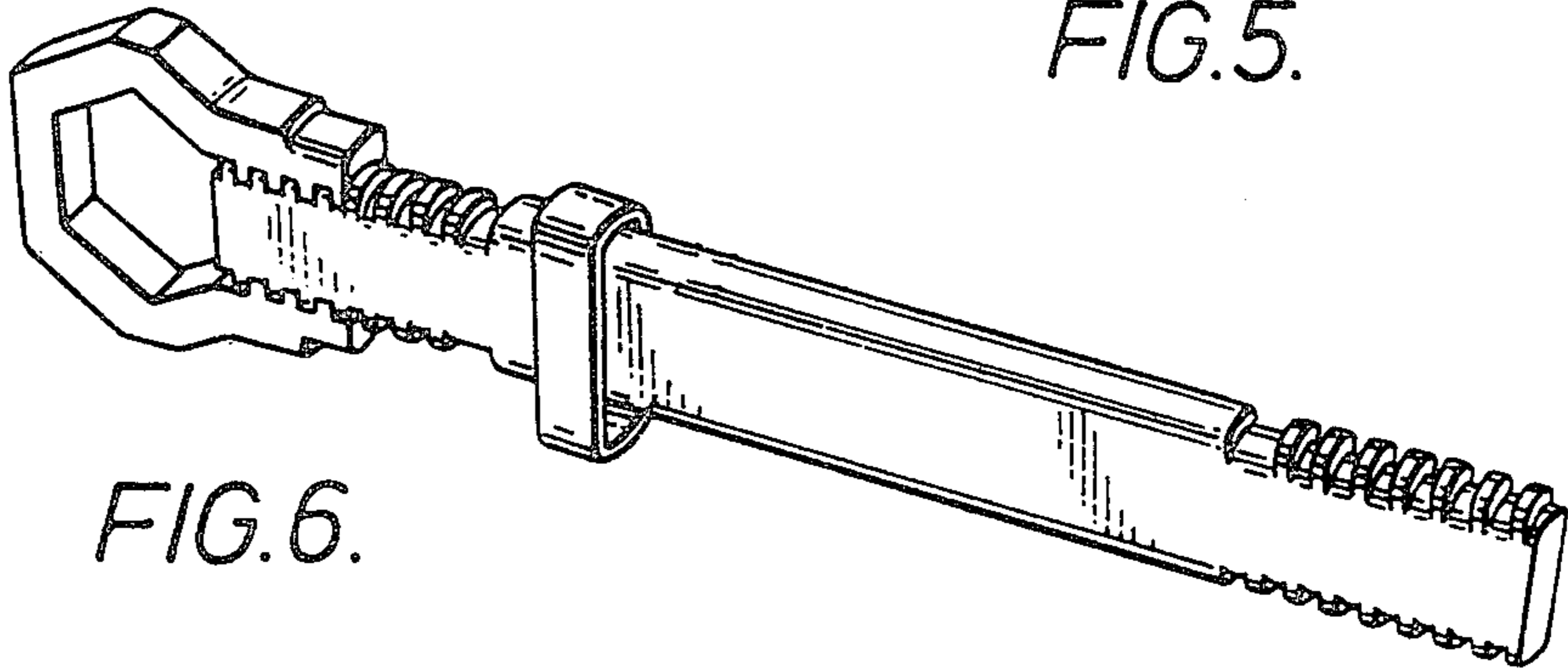

FIG. 6.