

[54] PAPER MONEY HOLDER

1,850,190 3/1932 Welch D11/79 X

[76] Inventor: Joseph H. Harris, 1149 Gail La., Sleepy Hollow, Ill. 60118

[**] Term: 14 Years

[21] Appl. No.: 441,043

[22] Filed: Dec. 27, 1982

[52] U.S. Cl. D99/34

[58] Field of Search D99/34; D11/79; 63/1 R, 63/1 A, 2

[56] References Cited

U.S. PATENT DOCUMENTS

- D. 11,457 10/1879 Aikin D11/79
- D. 12,436 8/1881 Fairchild D11/79 X
- D. 111,535 9/1938 Florman D3/63
- D. 258,874 4/1981 Hocq D11/79

OTHER PUBLICATIONS

Goldschmiede Zeitung, 4/77, p. 82, Pendant.

Primary Examiner—Bernard Ansher

Assistant Examiner—Terry Pfeffer

Attorney, Agent, or Firm—Mathew R. P. Perrone, Jr.

[57] CLAIM

The ornamental design for a paper money holder, as shown and described.

DESCRIPTION

FIG. 1 is a perspective view of a paper money holder showing my new design;

FIG. 2 is a side elevation thereof, the opposite side being a mirror image; and

FIG. 3 is a top plan view thereof.

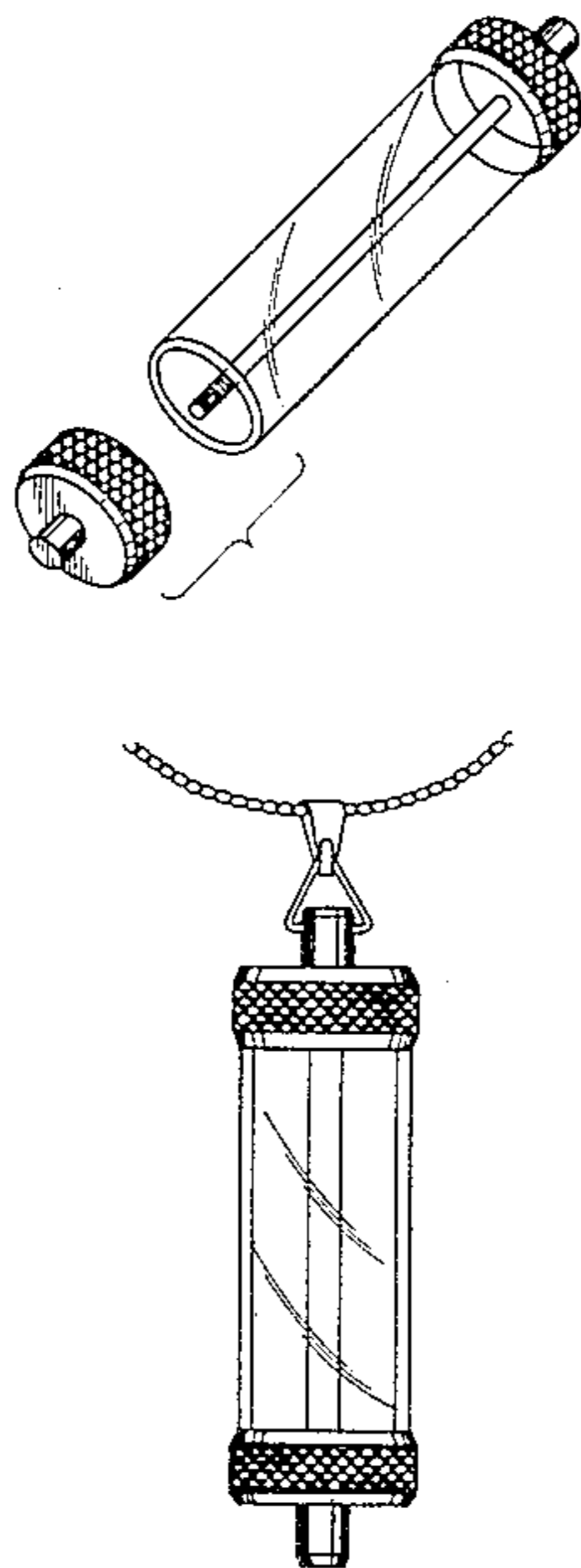

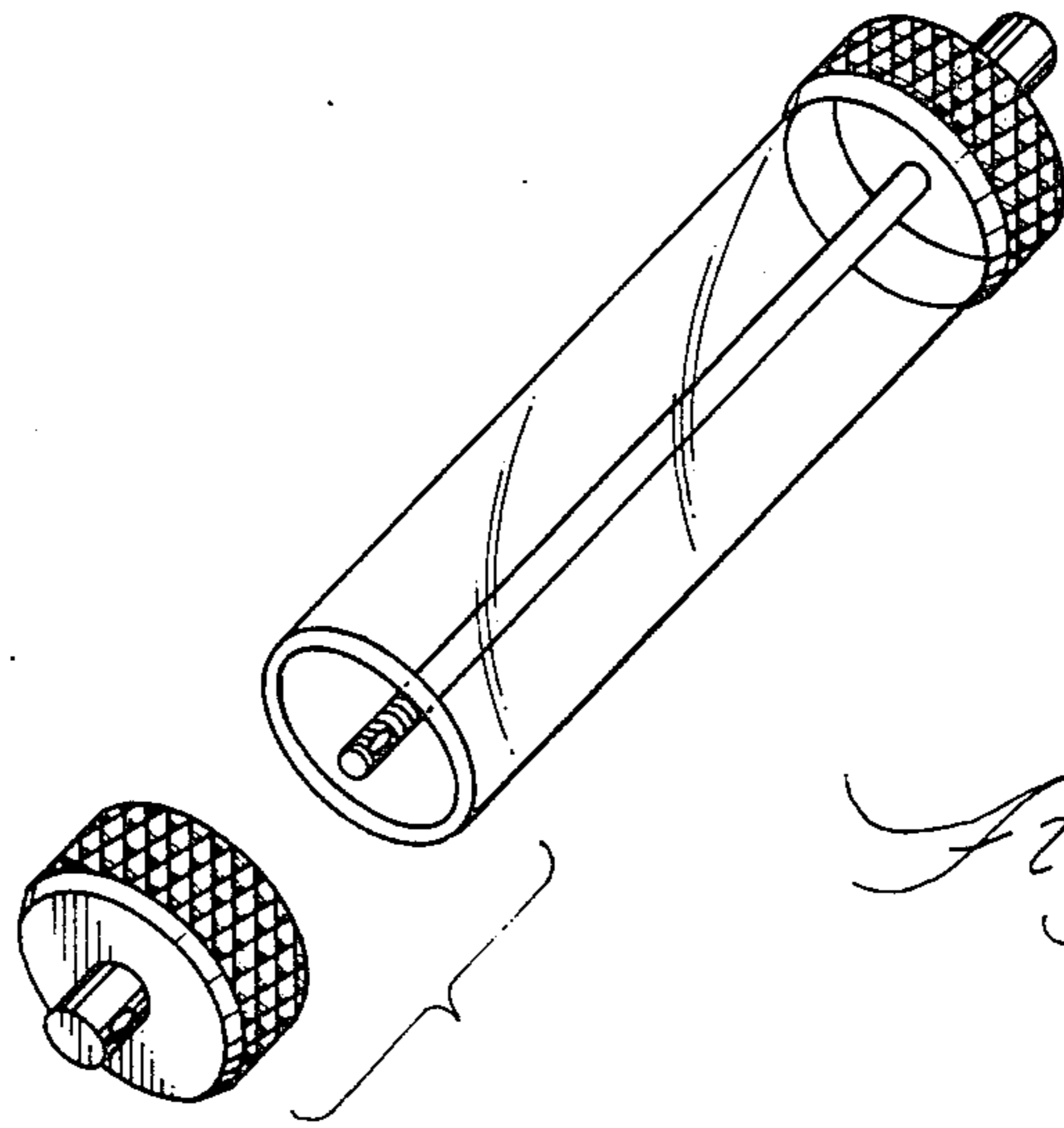

Fig. I

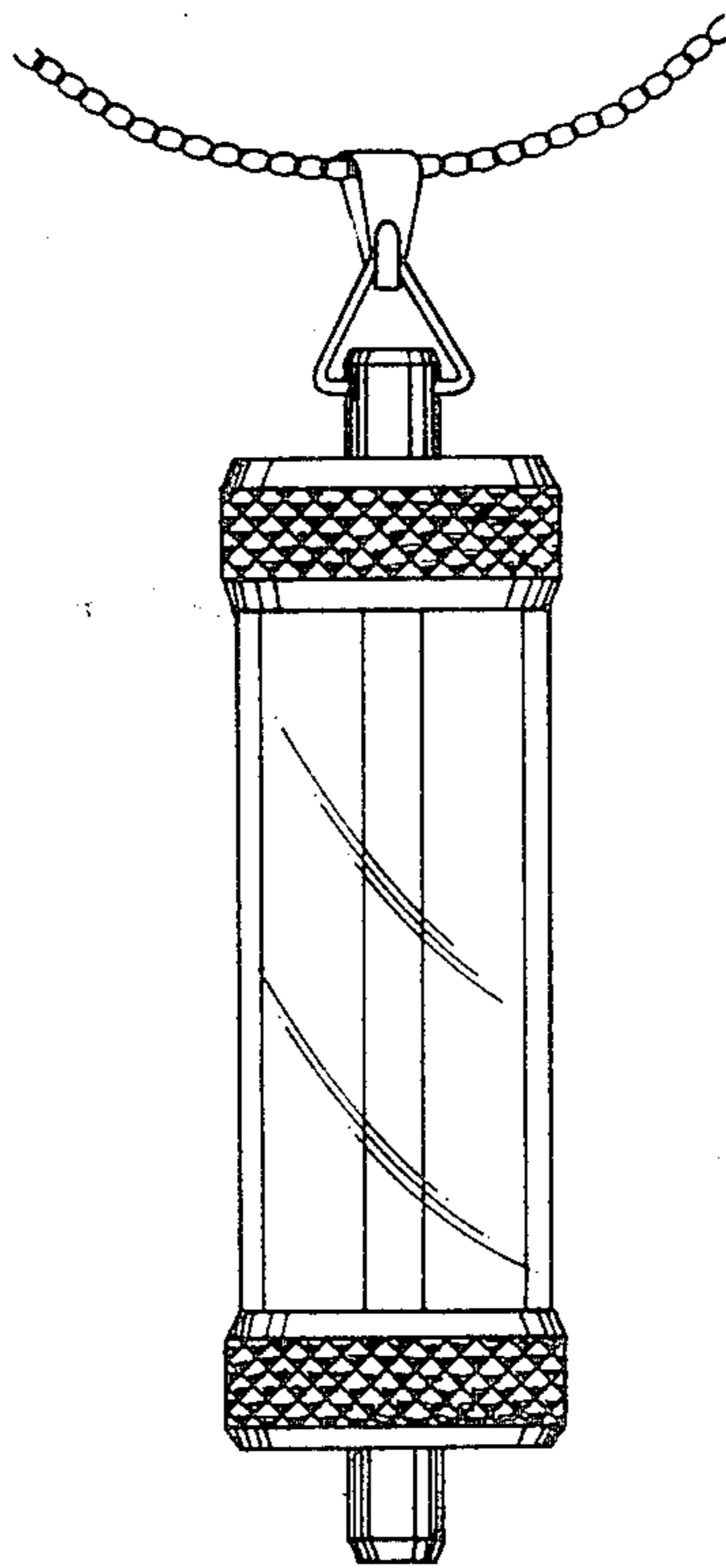

Fig. II

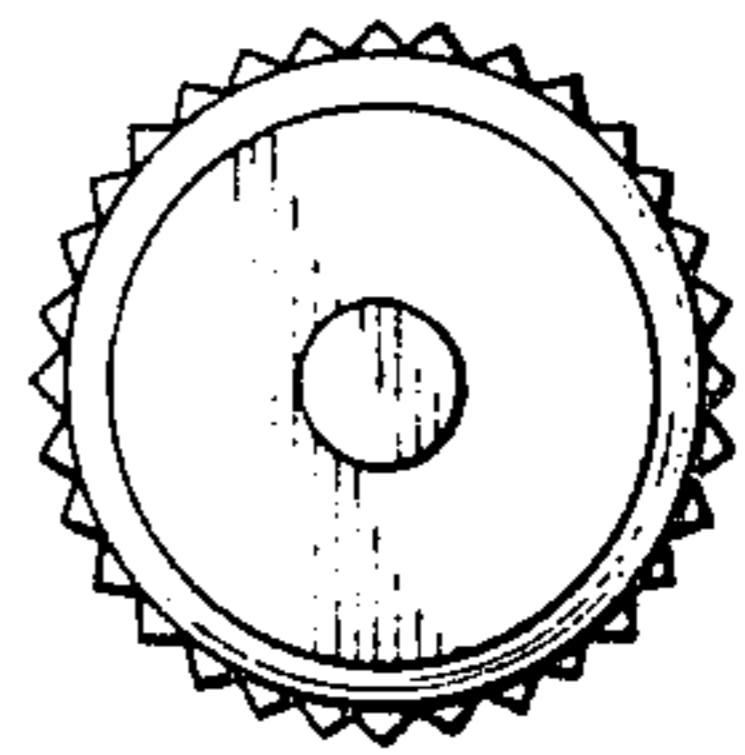

Fig. III