

[54] BICYCLE CARRIER BAGS

[75] Inventors: Brian R. Bepristis, San Jose; Richard A. Bepristis, Campbell, both of Calif.

[73] Assignee: Astro Nautics Plastic Mfg. Corporation, Santa Clara, Calif.

[\*\*] Term: 14 Years

[21] Appl. No.: 467,092

[22] Filed: Feb. 16, 1983

[52] U.S. Cl. .... D12/158

[58] Field of Search ..... D12/158; 224/32 R, 32 A

[56] References Cited

U.S. PATENT DOCUMENTS

- D. 209,185 11/1967 Lahti ..... D12/158
- 2,783,927 3/1957 Harley ..... 224/32 R

OTHER PUBLICATIONS

American Bicyclist & Motorcyclist, 4/75, p. 40, MX Trail Panniers, bottom right side of page.

Primary Examiner—James M. Gandy  
Attorney, Agent, or Firm—Paul L. Hickman

[57] CLAIM

The ornamental design for bicycle carrier bags, as shown and described.

DESCRIPTION

FIG. 1 is a side elevational view of the bicycle carrier bags showing our new design; the opposite side being a mirror image thereof.

FIG. 2 is a front elevational view thereof.

FIG. 3 is a rear elevational view thereof.

FIG. 4 is a bottom plan view thereof.

FIG. 5 is a top plan view thereof.

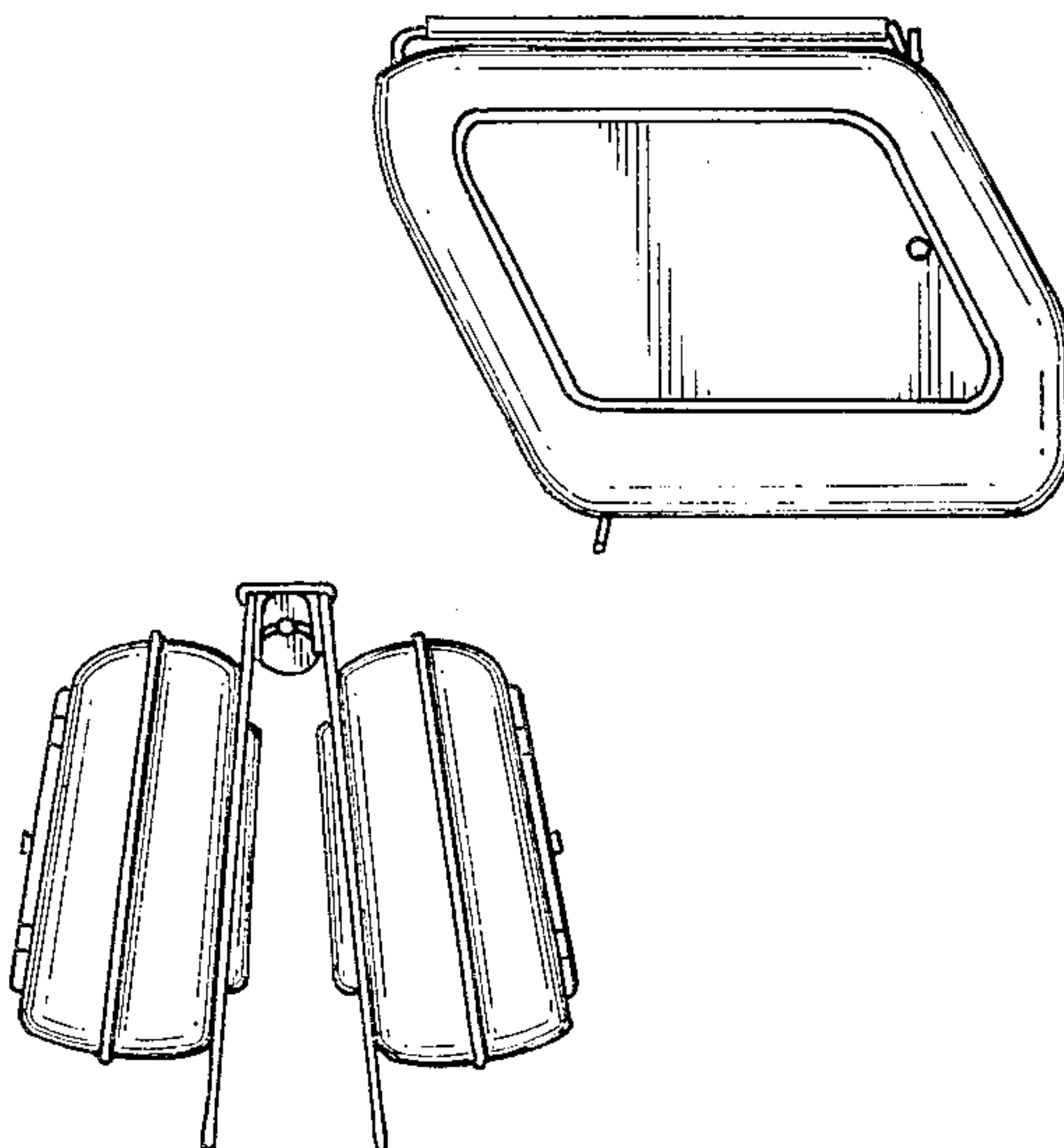

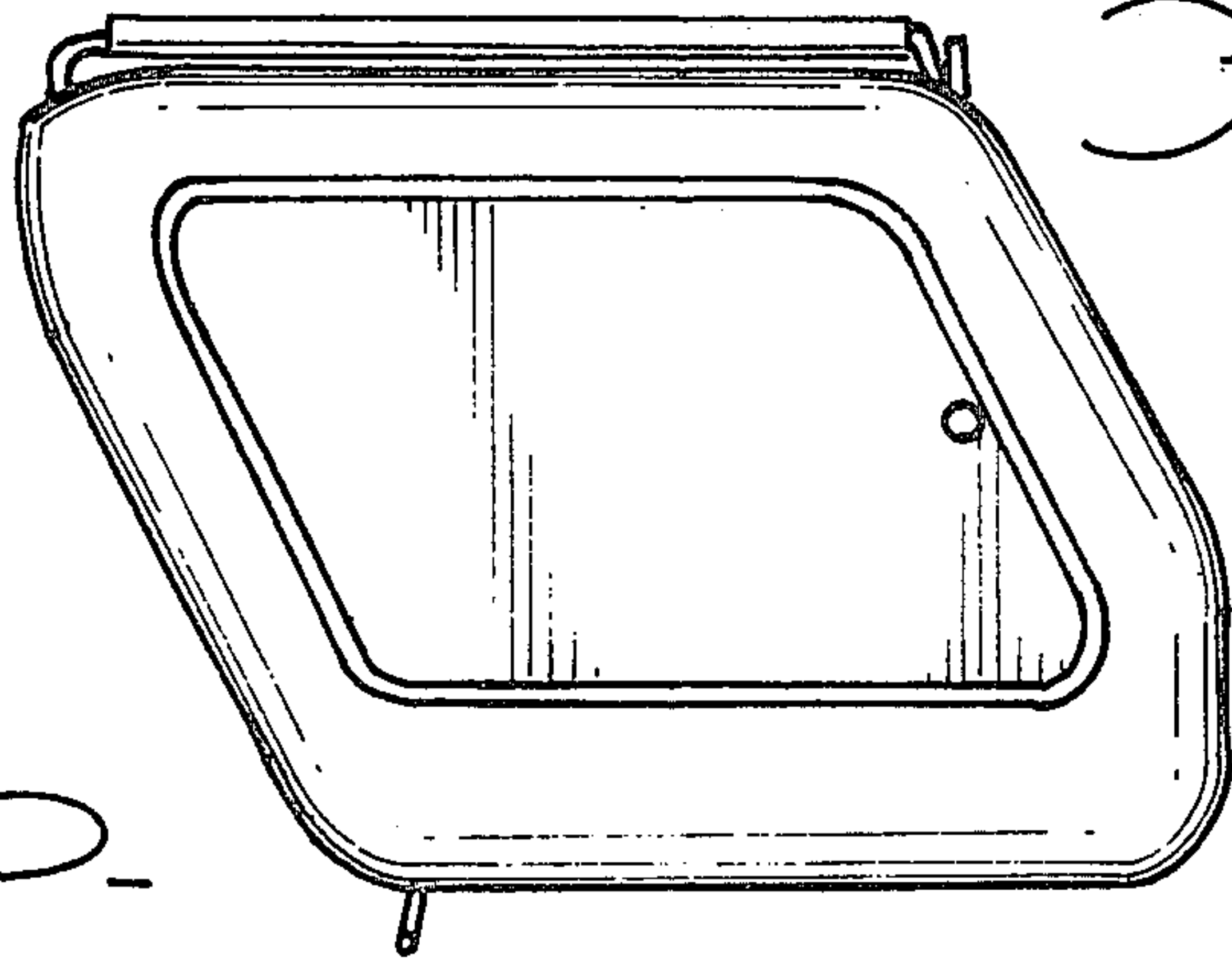

FIG. 1-

FIG. 2-

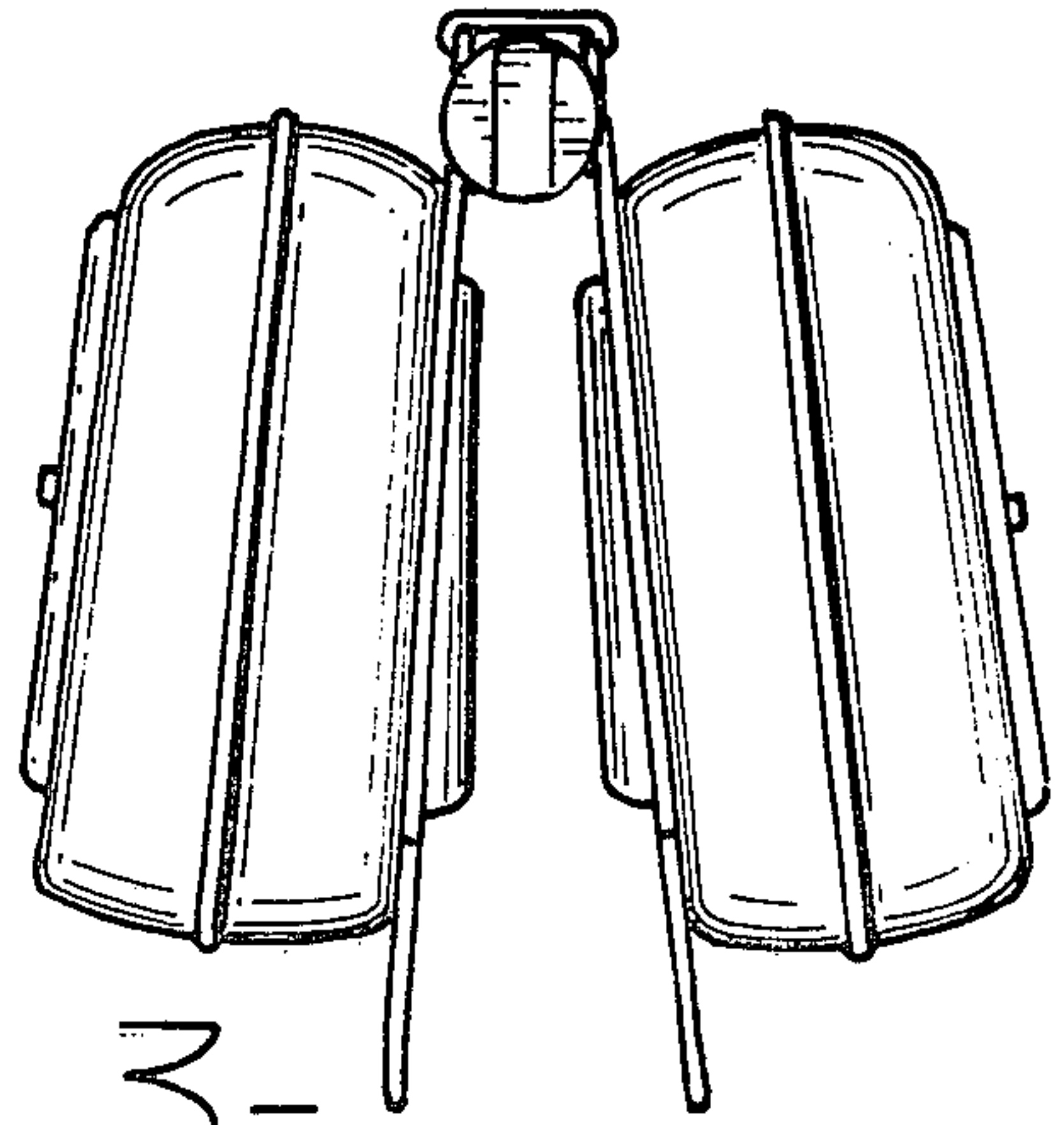
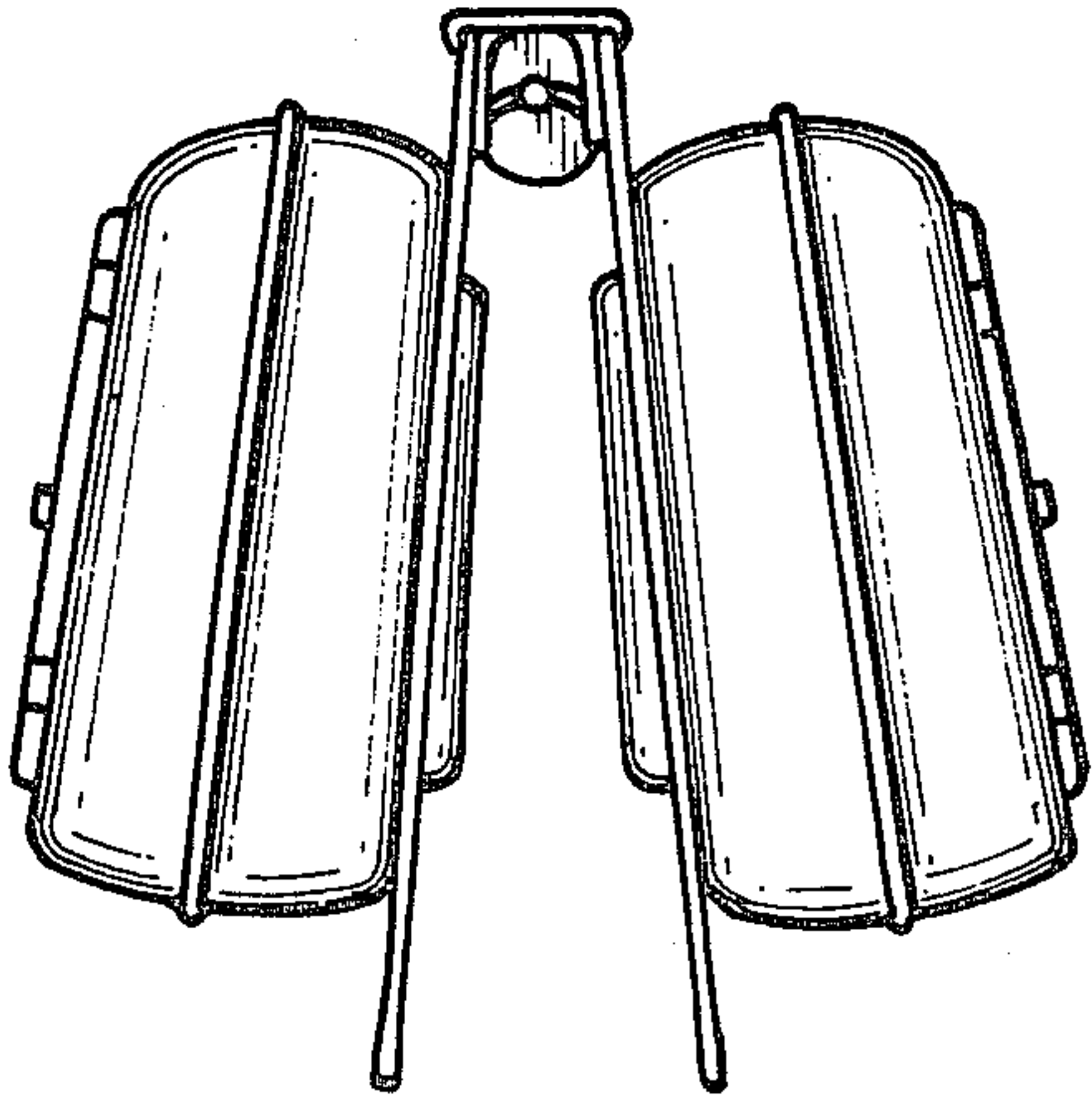

FIG. 3-

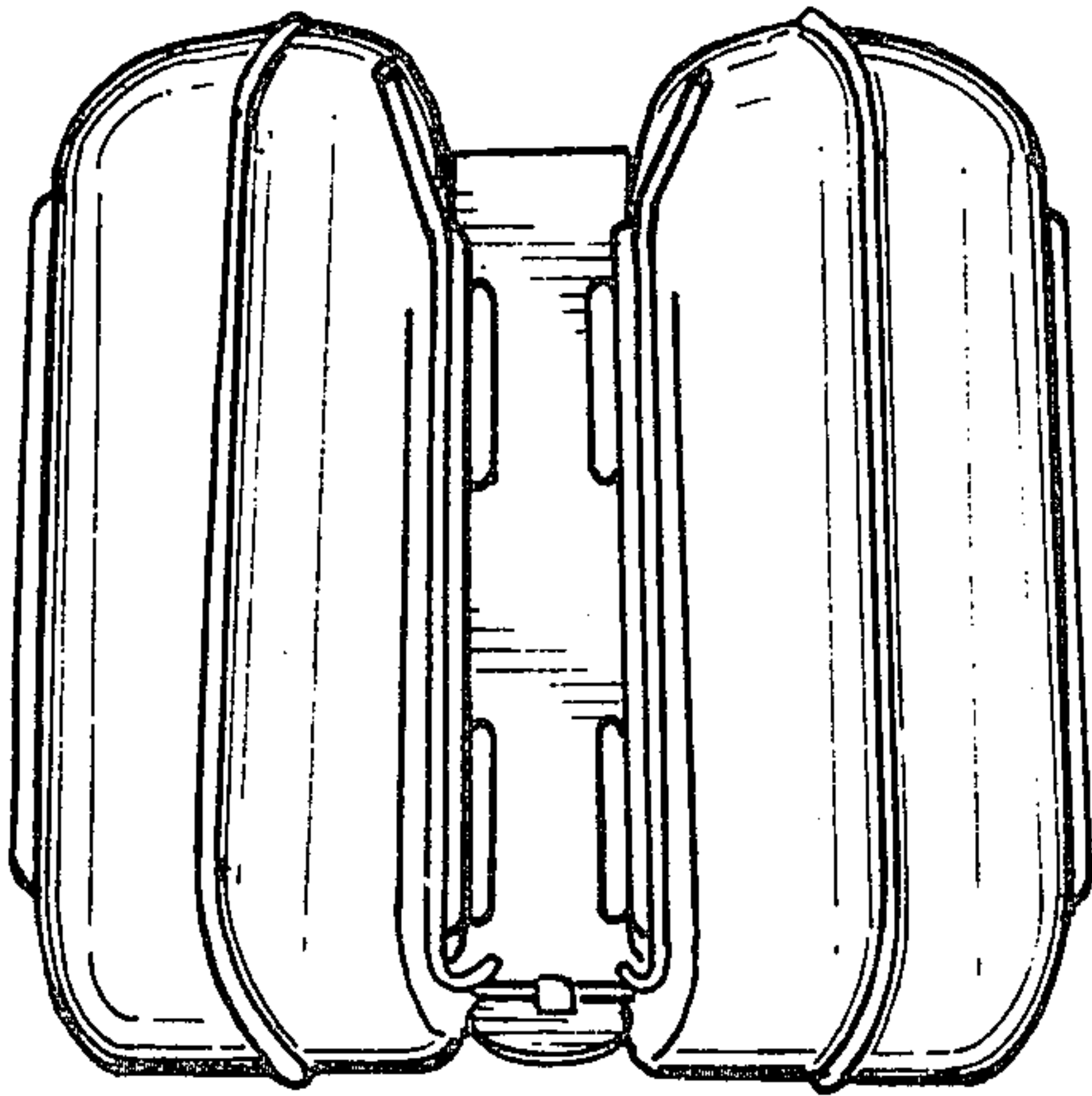

FIG. 4-

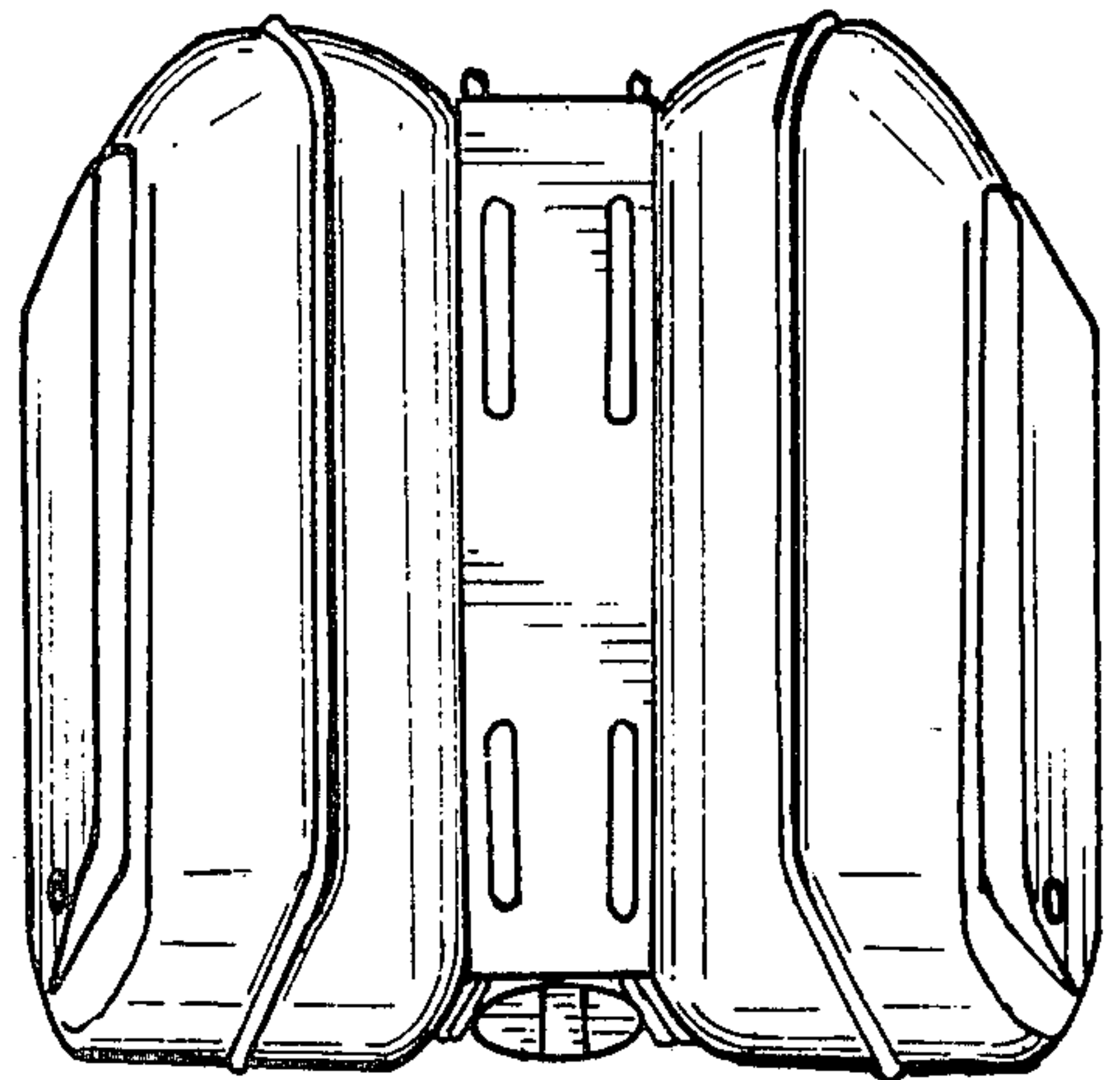

FIG. 5-