

# United States Patent [19]

Ishizaki

[11] Patent Number: **Des. 281,158**

[45] Date of Patent: **\*\* Oct. 29, 1985**

[54] **LOUDSPEAKER**

[75] Inventor: **Hideaki Ishizaki, Tokyo, Japan**

[73] Assignee: **Pioneer Electronic Corporation, Tokyo, Japan**

[\*\*] Term: **14 Years**

[21] Appl. No.: **497,937**

[22] Filed: **May 25, 1983**

[30] **Foreign Application Priority Data**

Nov. 30, 1982 [JP] Japan ..... 57-53801

[52] U.S. Cl. .... **D14/34; D14/33**

[58] Field of Search ..... D14/30, 32-34,  
D14/37, 39

[56] **References Cited**

**U.S. PATENT DOCUMENTS**

D. 259,877 7/1981 Barbera ..... D14/34

D. 269,871 7/1983 Ishizaki ..... D14/34

D. 269,872 7/1983 Ishizaki ..... D14/34

D. 276,518 11/1984 Clemans ..... D14/33

**OTHER PUBLICATIONS**

"Pioneer Car Stereo Systems" Catalog #CS180, ©1980, p. 36, TX-X9 Speakers.

*Primary Examiner*—Jane E. Corrigan  
*Attorney, Agent, or Firm*—Sughrue, Mion, Zinn, Macpeak and Seas

[57] **CLAIM**

The ornamental design for a loudspeaker, as shown.

**DESCRIPTION**

FIG. 1 is a front elevational view of a loudspeaker showing my new design;  
FIG. 2 is a rear elevational view;  
FIG. 3 is a top plan view;  
FIG. 4 is a bottom plan view;  
FIG. 5 is a left side elevational view;  
FIG. 6 is a right side elevational view; and  
FIG. 7 is a front, top and left side perspective view.

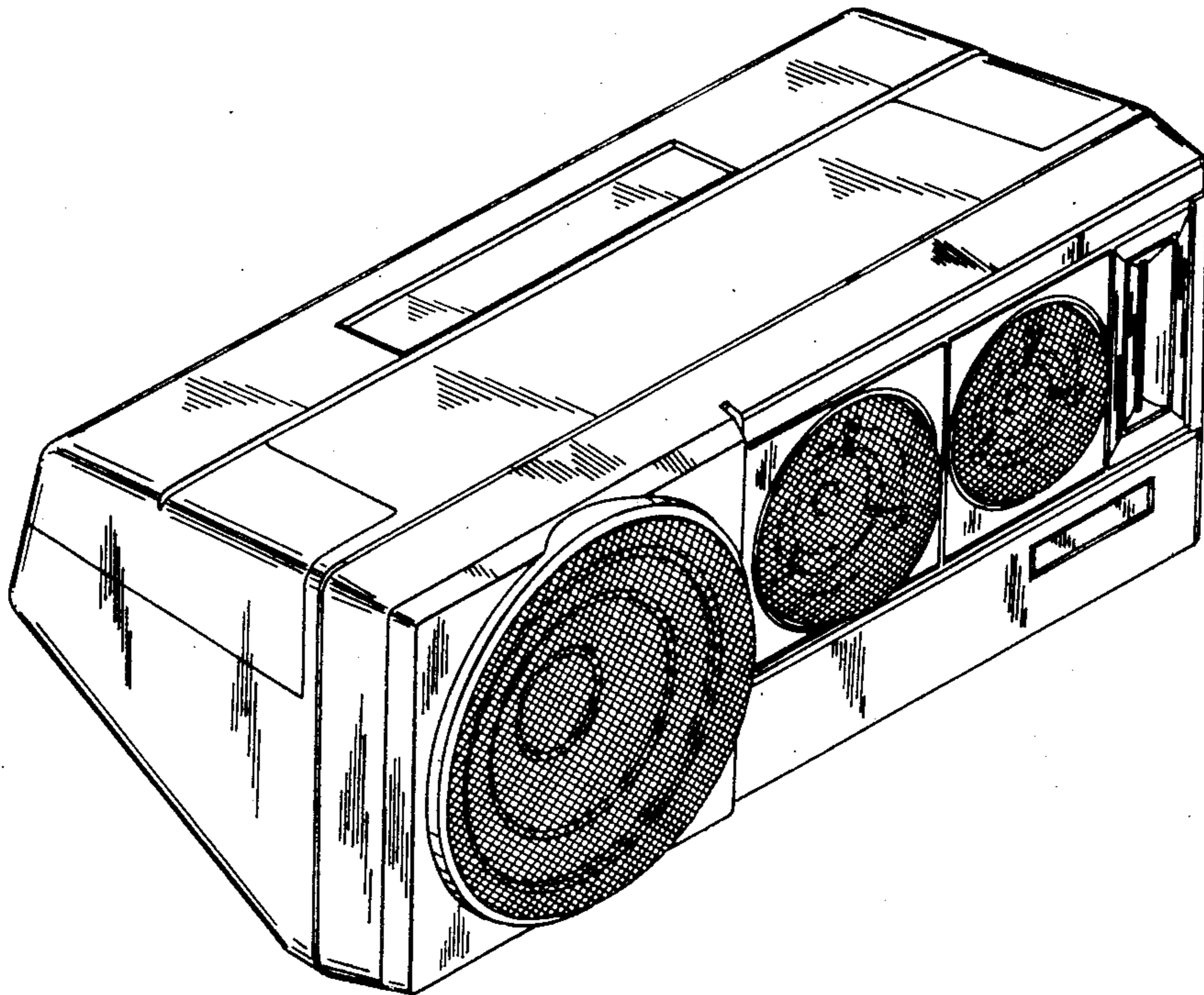

FIG. 1

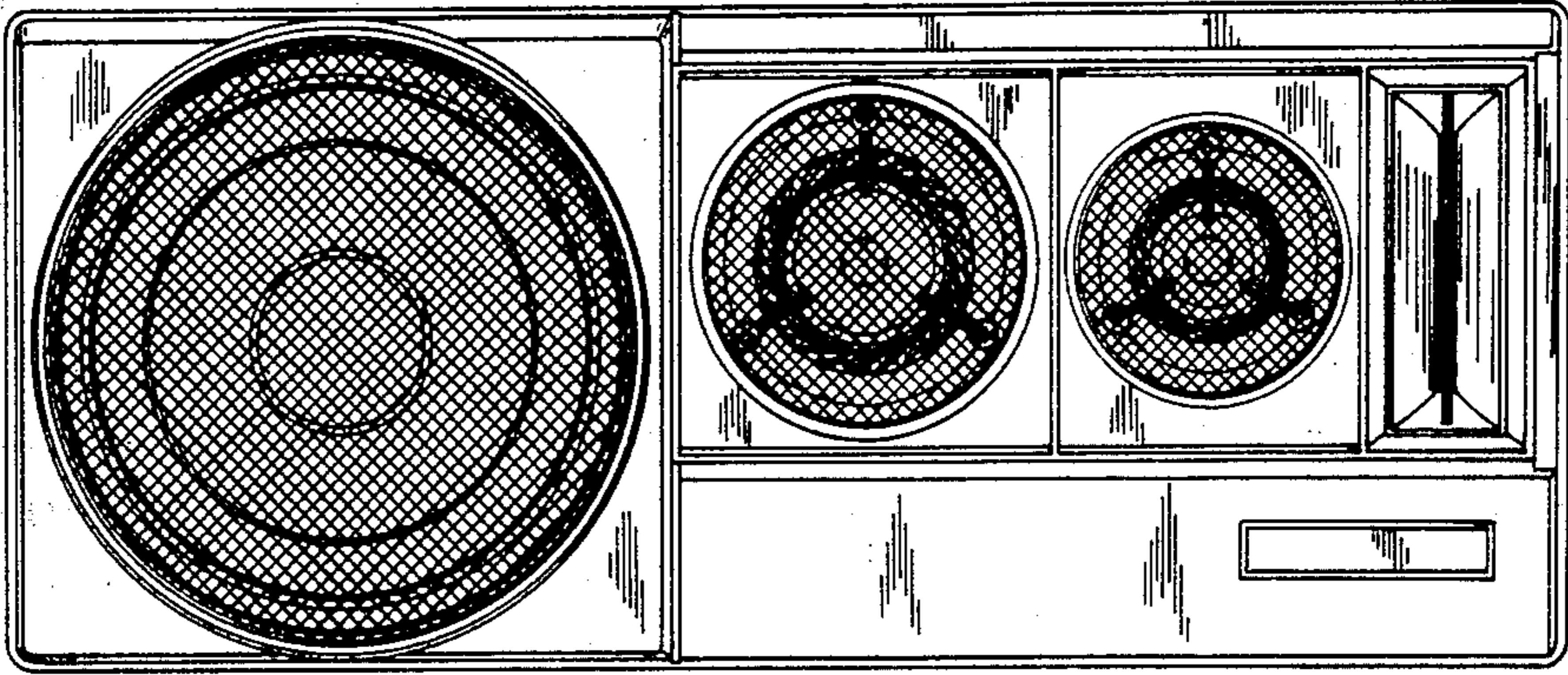

FIG. 2

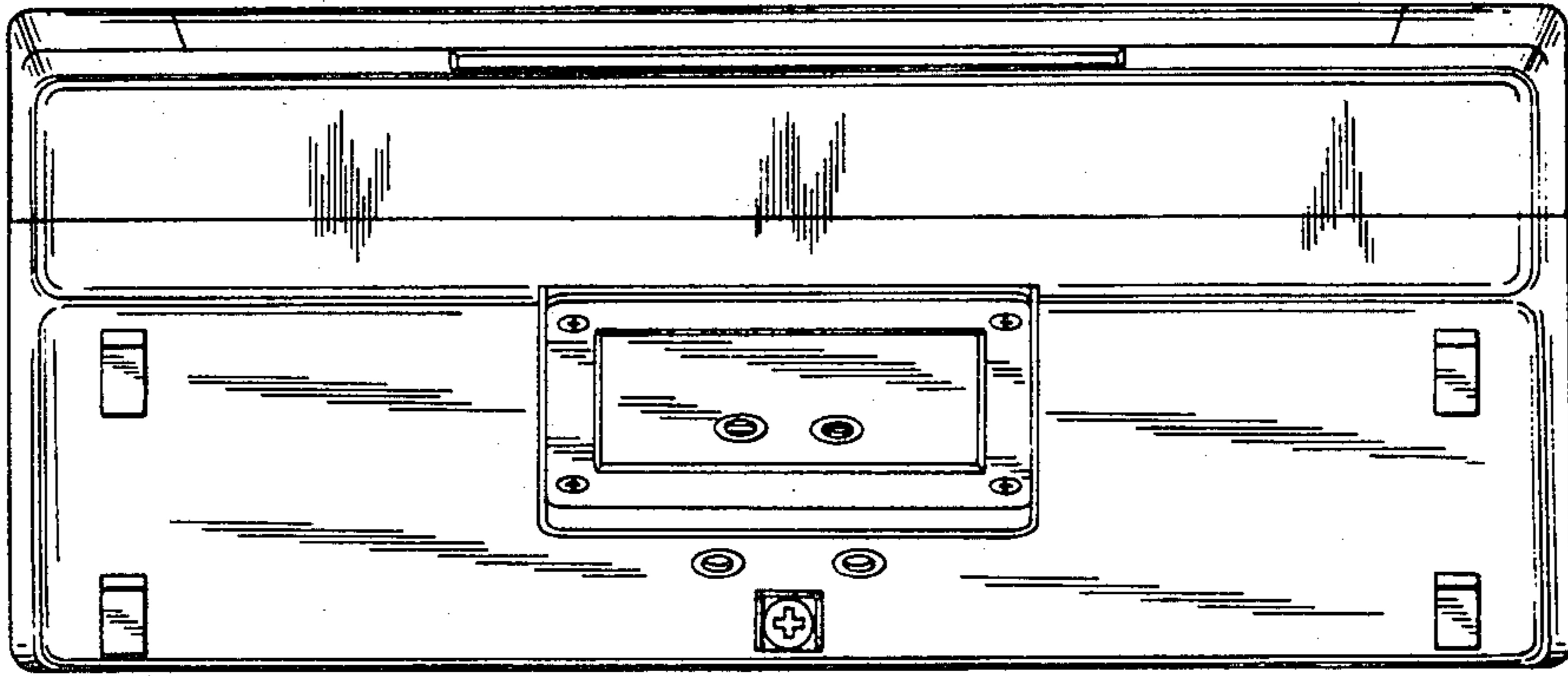

FIG. 3

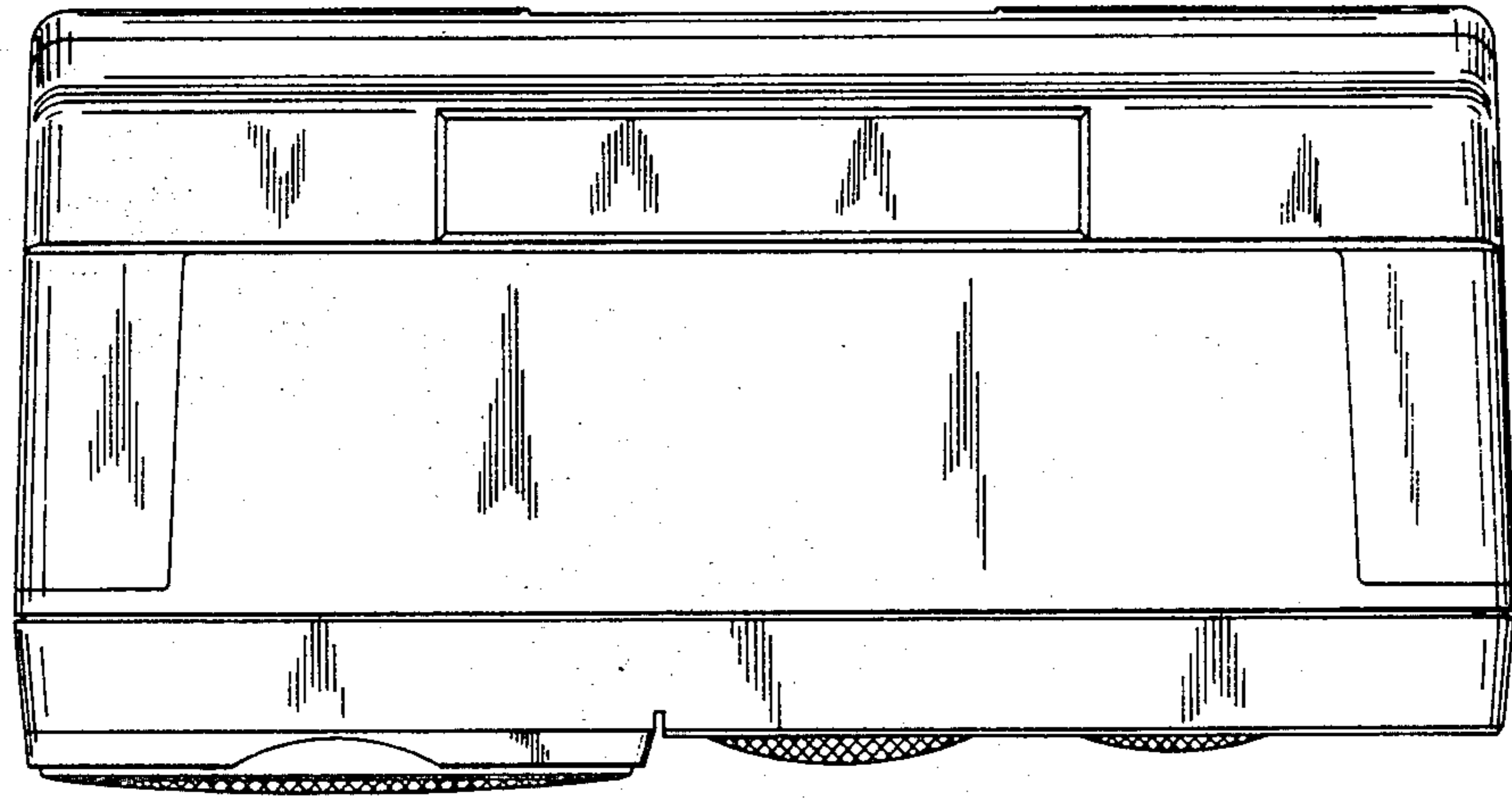

FIG. 4

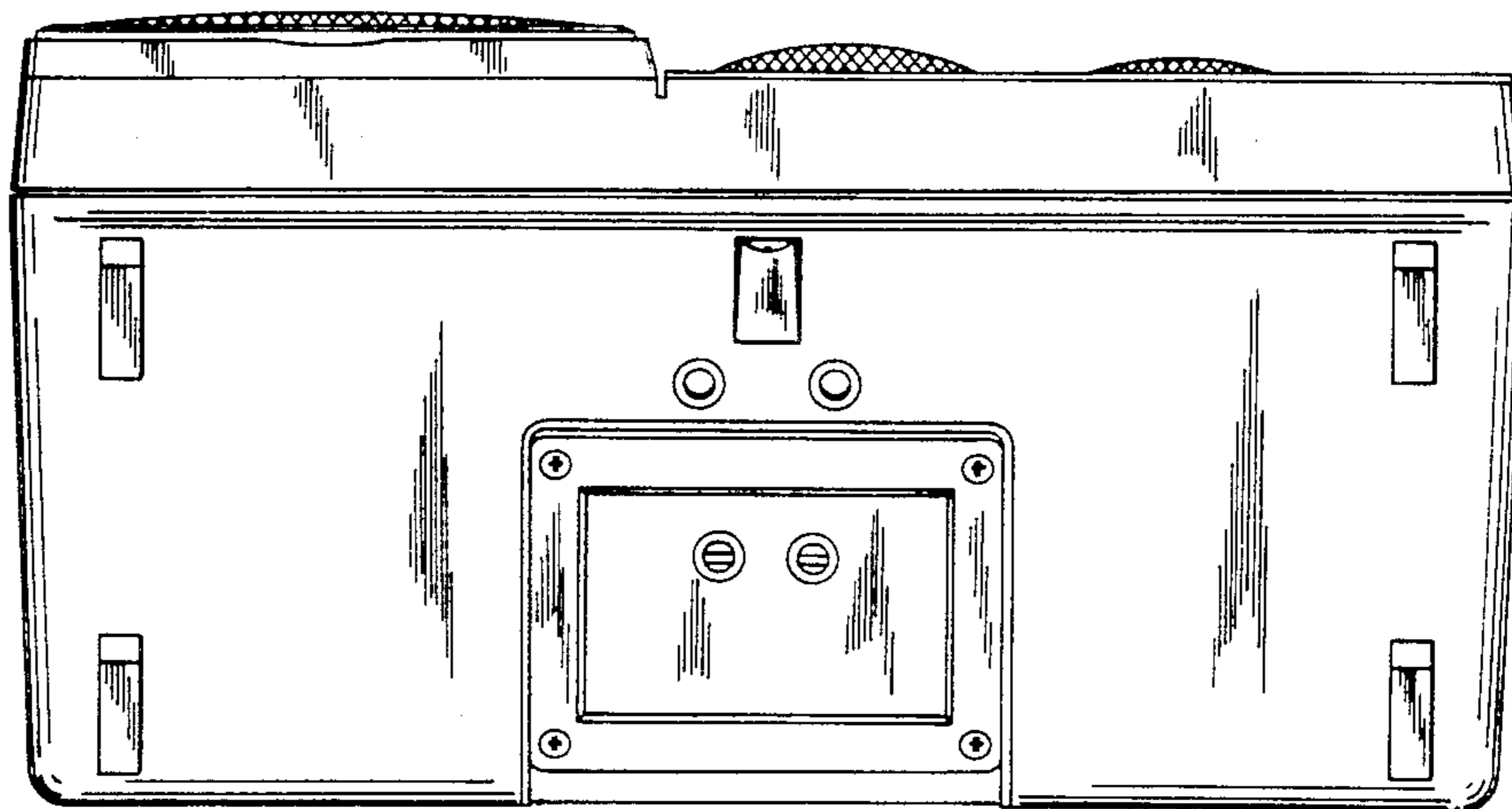

FIG. 5

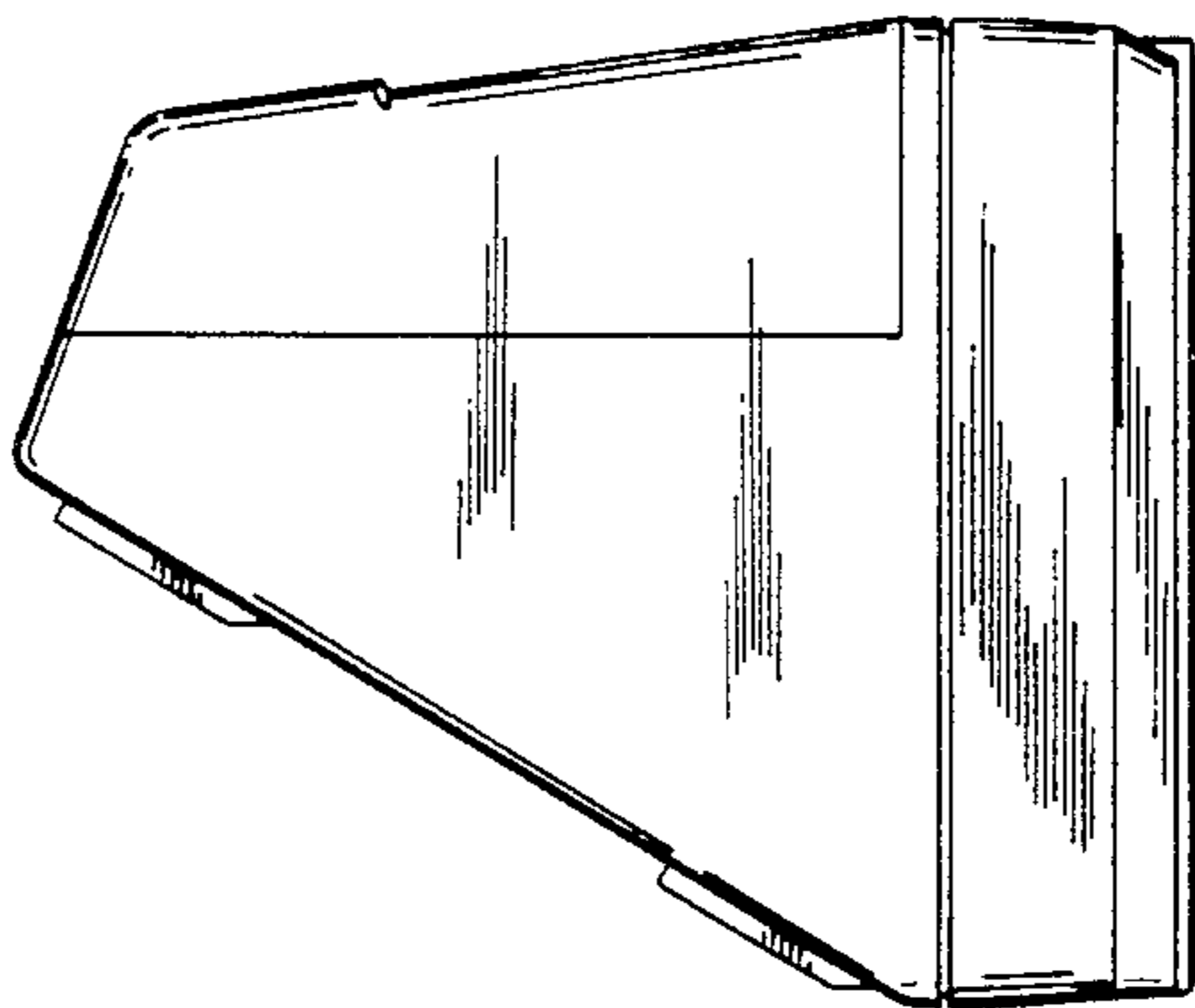

FIG. 6

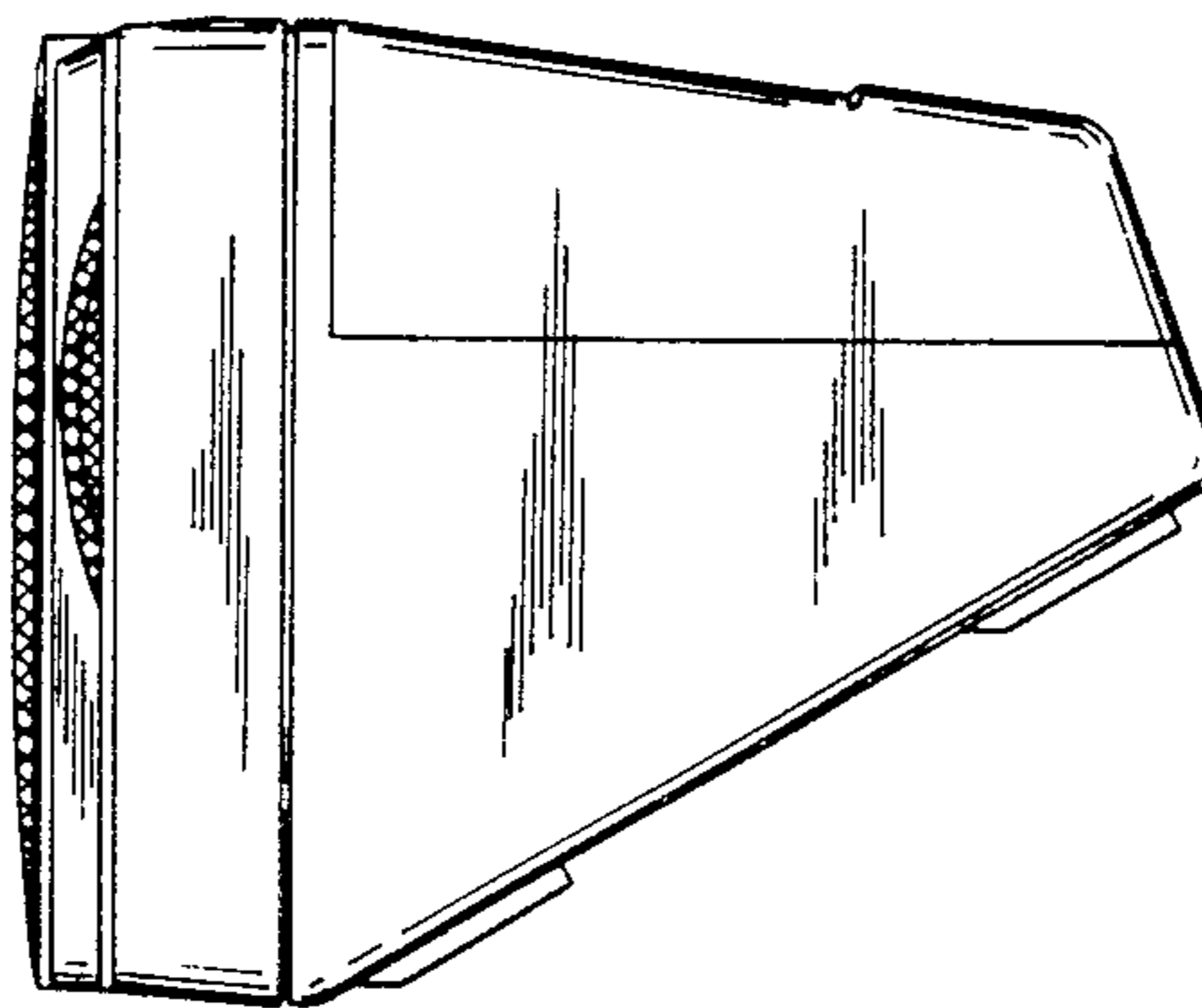

FIG. 7

