

United States Patent [19]

Kuna et al.

[11] Patent Number: **Des. 281,000**

[45] Date of Patent: **** Oct. 15, 1985**

[54] **TOY VEHICLE**

[75] Inventors: **Wayne A. Kuna**, Oak Park; **John R. Wildman**, North Riverside; **Gale D. Jenkins, Jr.**, Bolingbrook; **Mitchel J. Frumkin**, Villa Park, all of Ill.

[73] Assignee: **Marvin Glass & Associates**, Chicago, Ill.

[**] Term: **14 Years**

[21] Appl. No.: **485,340**

[22] Filed: **Apr. 11, 1983**

[52] U.S. Cl. **D21/134; D21/137**

[58] Field of Search **D21/76, 78, 79, 80, D21/81, 128, 131, 132, 133, 134, 135, 136, 137, 139, 140; 280/87.01, 87.02 R; 446/433, 440, 451, 465, 466**

[56] **References Cited**

U.S. PATENT DOCUMENTS

D. 211,809 7/1968 Genin D21/134

D. 275,872 10/1984 Manning et al. D21/134
D. 275,874 10/1984 Manning et al. D21/140
D. 277,494 2/1985 Lerch D21/136

OTHER PUBLICATIONS

Hong Kong Toys, 1983, p. 253, Item #8002B, Toy Vehicle.

Primary Examiner—Charles A. Rademaker
Attorney, Agent, or Firm—Ross, Ross & Flavin

[57] **CLAIM**

The ornamental design for toy vehicle, as shown and described.

DESCRIPTION

FIG. 1 is a front perspective view of a toy vehicle showing our new design;
FIG. 2 is a rear perspective view thereof;
FIG. 3 is a top perspective view thereof;
FIG. 4 is another front perspective view thereof;
FIG. 5 is another rear perspective view thereof; and
FIG. 6 is a bottom perspective view thereof.

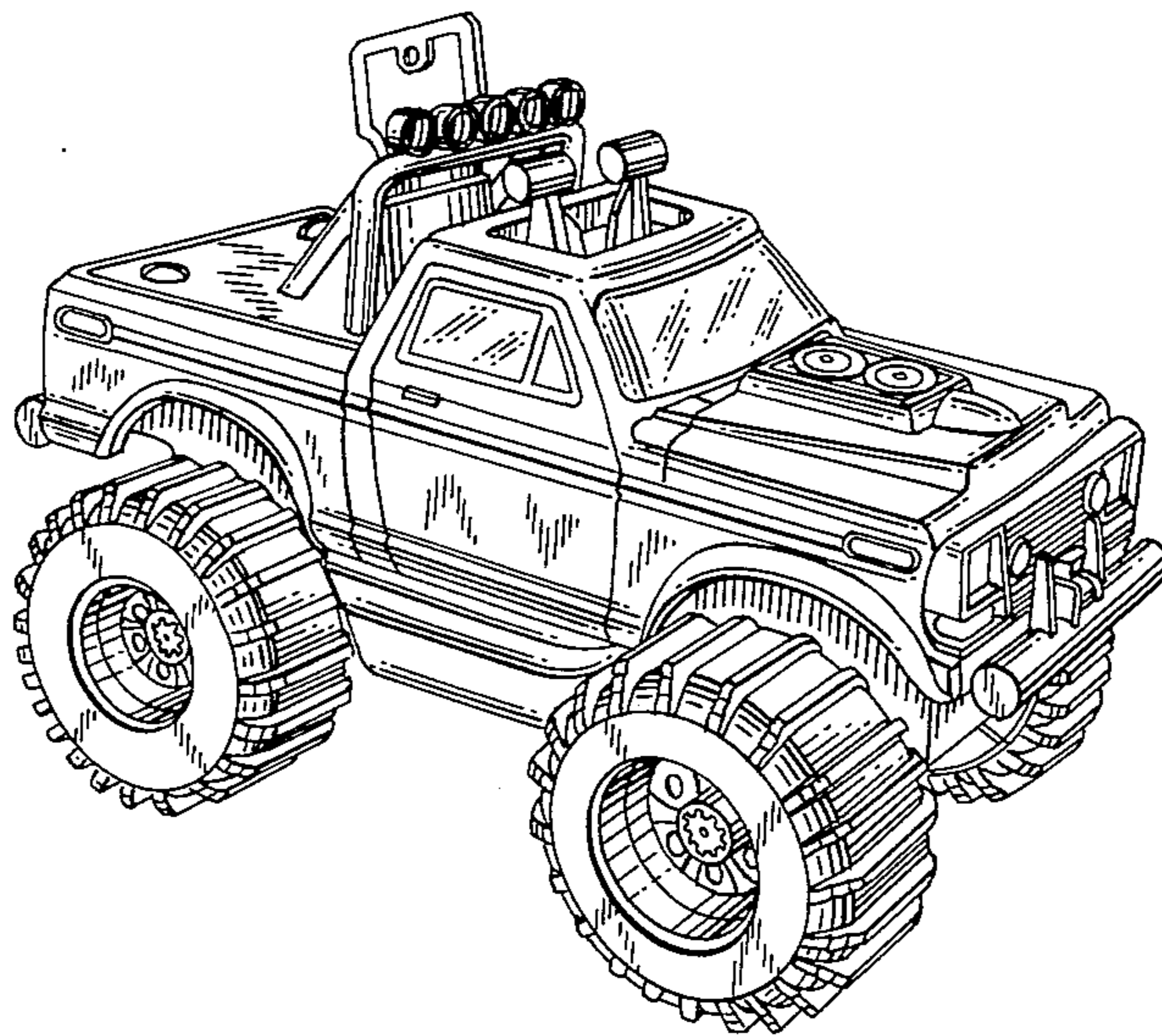

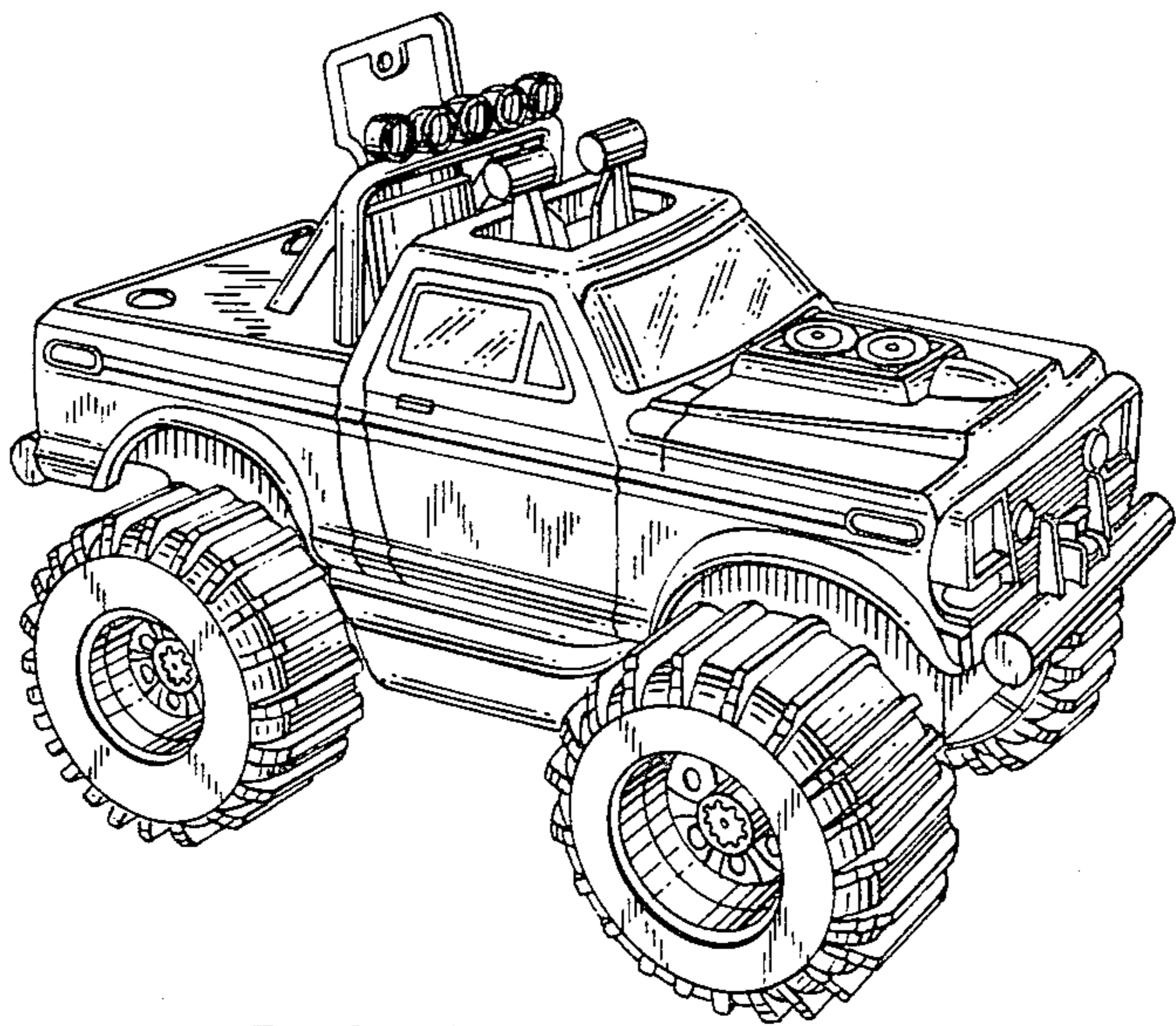

FIG. 1

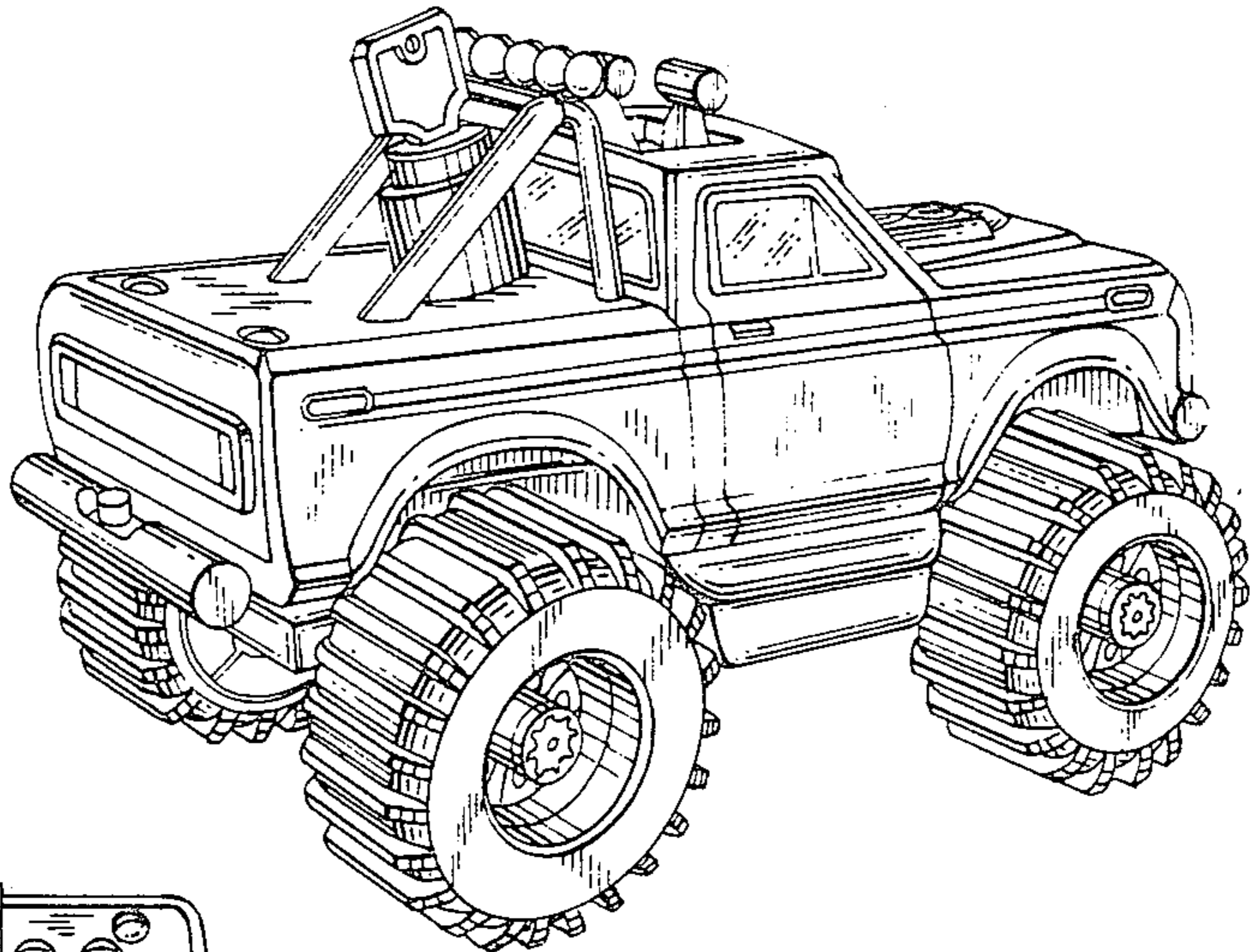

FIG. 2

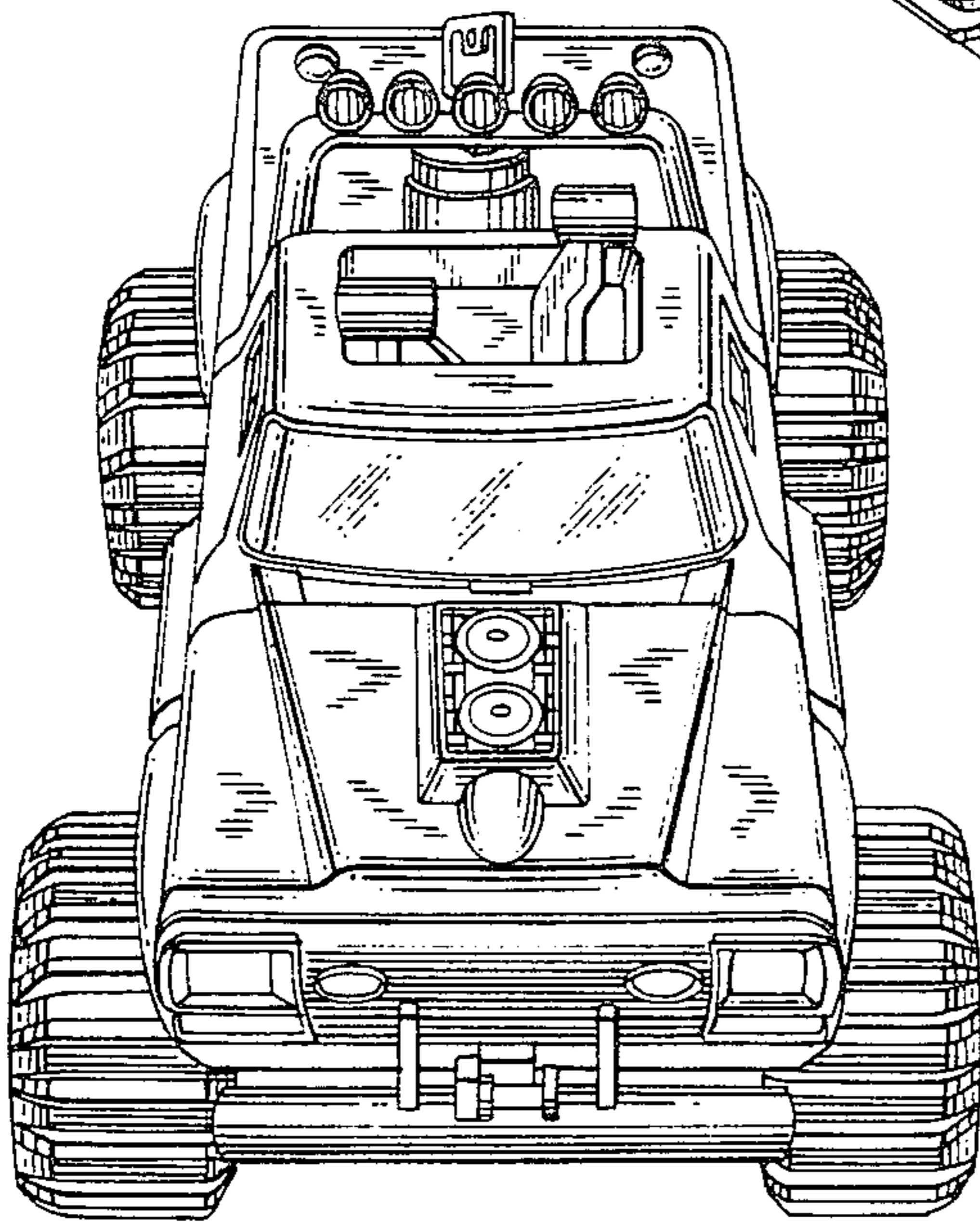

FIG. 3

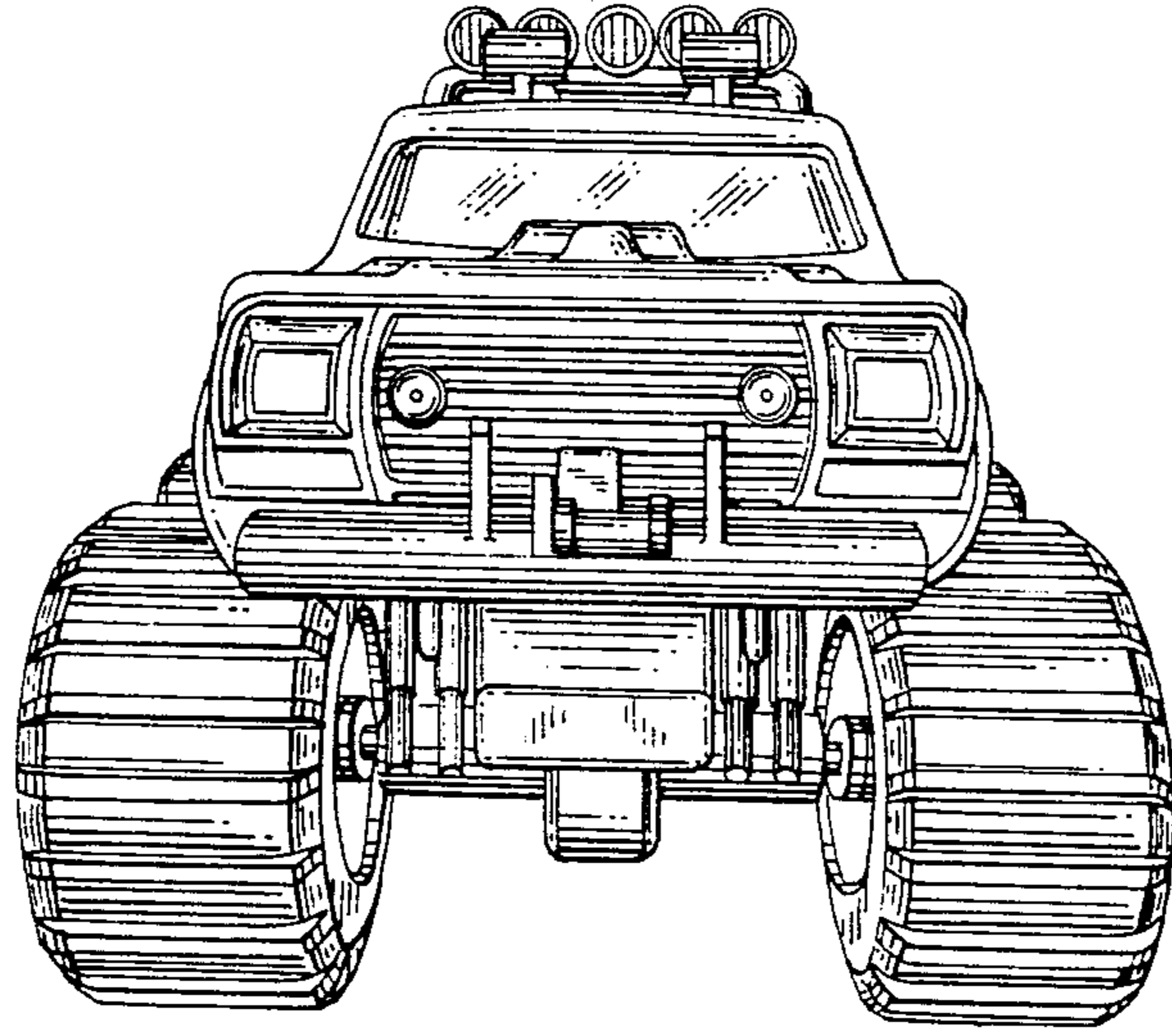

FIG. 4

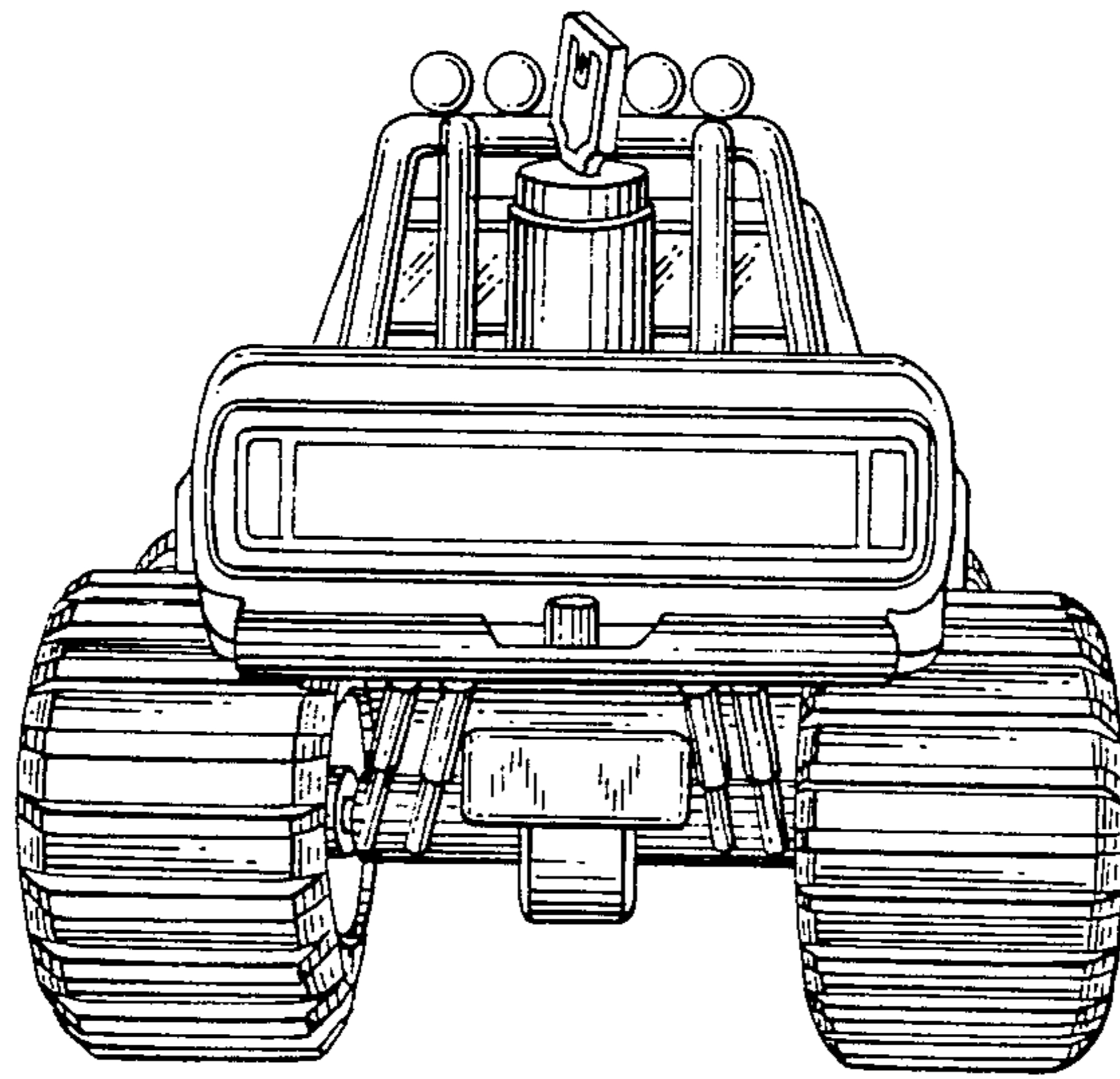

FIG. 5

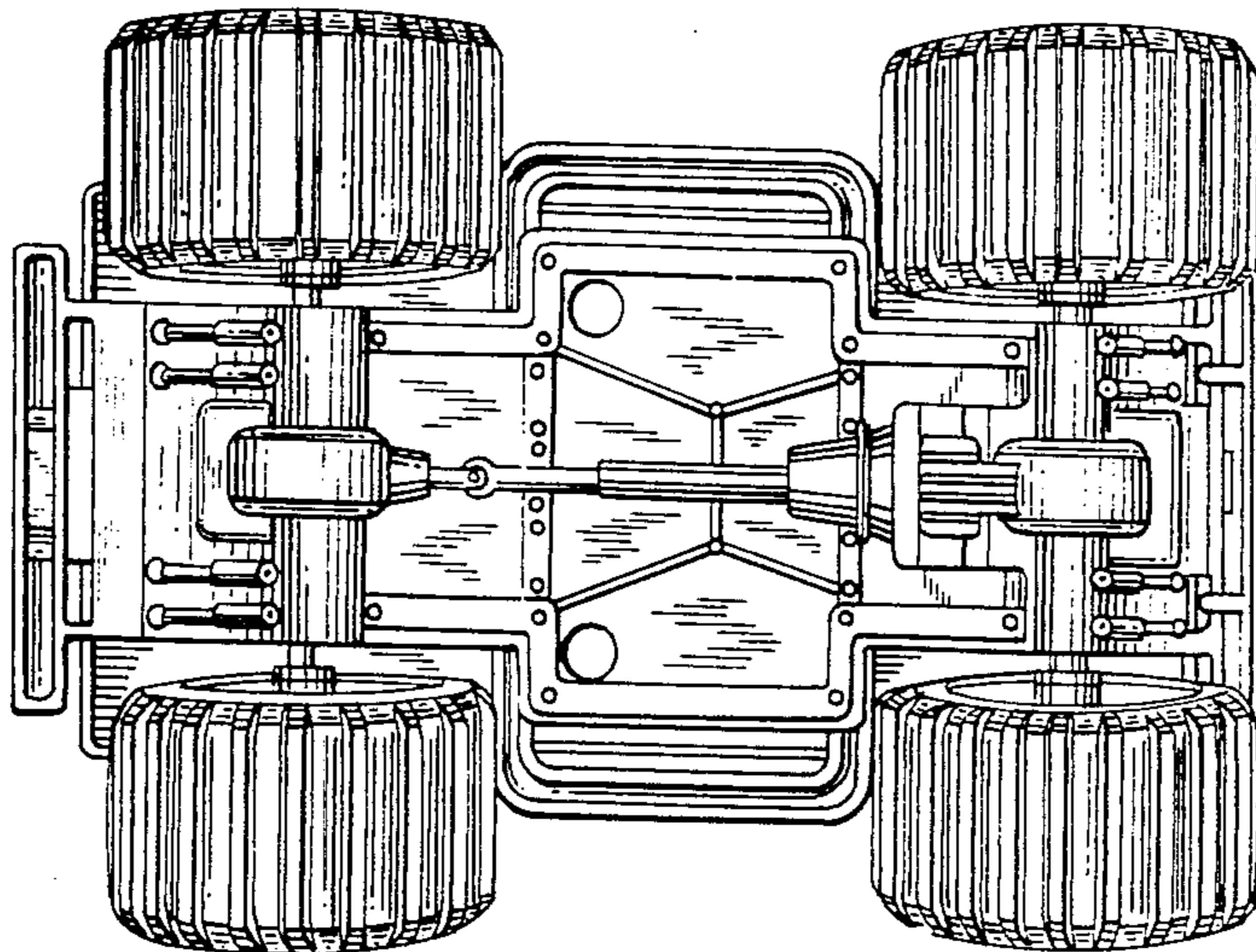

FIG. 6