

[54] TRICYCLE

[76] Inventors: Myung K. Oh, San 2-9, Tuck Eun-ri, Shin Do-eup, Koyang-goon, Kyung Gi-do; Myung S. Koo, 47-3, Namchang-dong, Chung-ku, Seoul, both of Rep. of Korea

[\*\*] Term: 14 Years

[21] Appl. No.: 536,812

[22] Filed: Sep. 28, 1983

[52] U.S. Cl. .... D12/112

[58] Field of Search ..... D12/112, 113; 280/282, 280/259, 244, 247, 248

[56] References Cited

U.S. PATENT DOCUMENTS

D. 225,545	12/1972	Novak, Jr. ....	D12/112
2,884,259	4/1959	Snodgrass .....	280/248
4,460,190	7/1984	Spiess .....	280/247

Primary Examiner—James M. Gandy  
Attorney, Agent, or Firm—Armstrong, Nikaido, Marmelstein & Kubovcik

[57] CLAIM

The ornamental design for a tricycle, as shown and described.

DESCRIPTION

FIG. 1 is a perspective view of a tricycle showing our new design.

FIG. 2 is a top plan view thereof.

FIG. 3 is a side elevation view thereof.

FIG. 4 is a bottom plan view thereof.

FIG. 5 is a side elevation view thereof opposite to that shown in FIG. 3.

FIG. 6 is a front elevation view thereof.

FIG. 7 is a rear elevation view thereof.

FIG. 8 is a section view thereof taken along line VIII-VIII in FIG. 2.

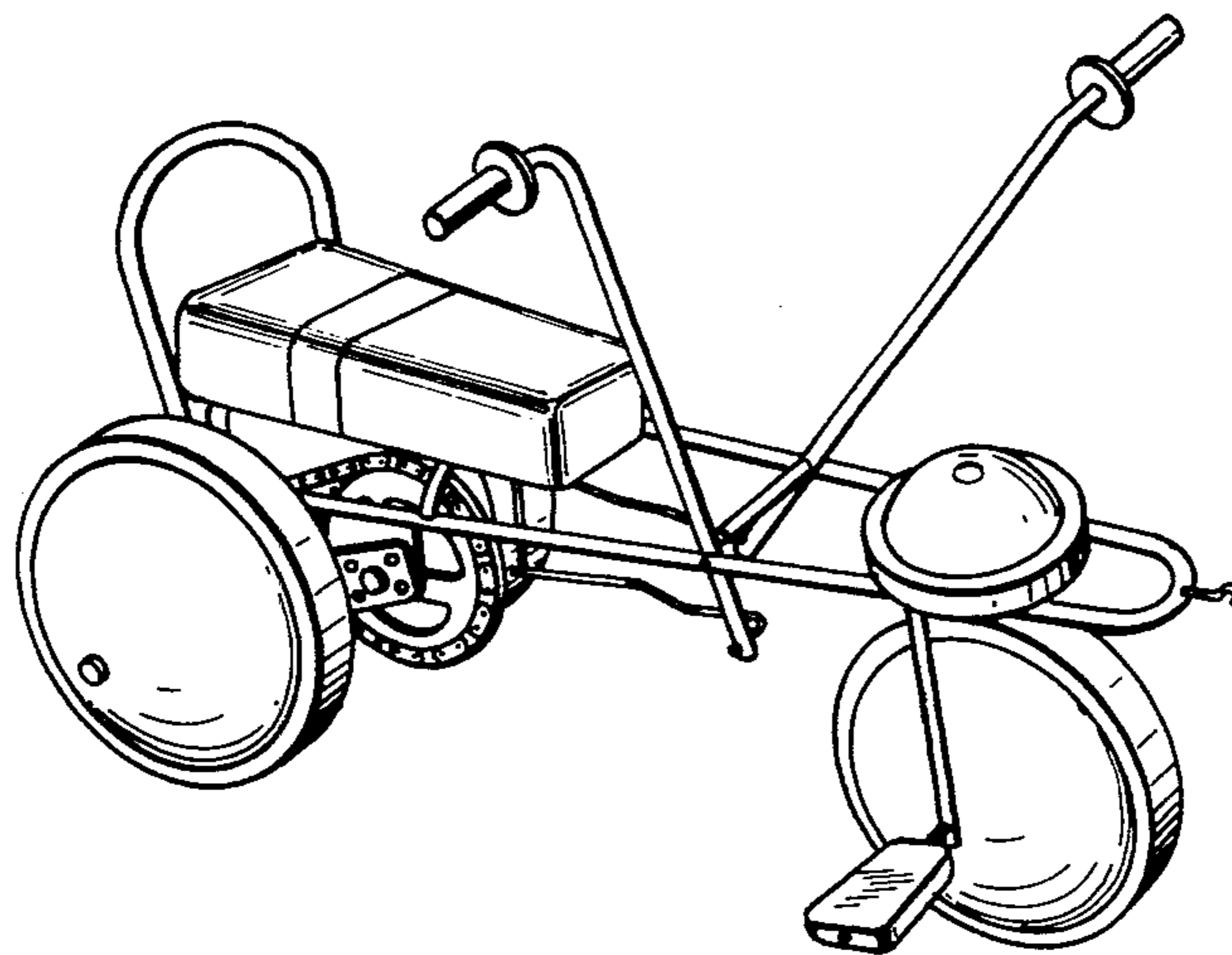

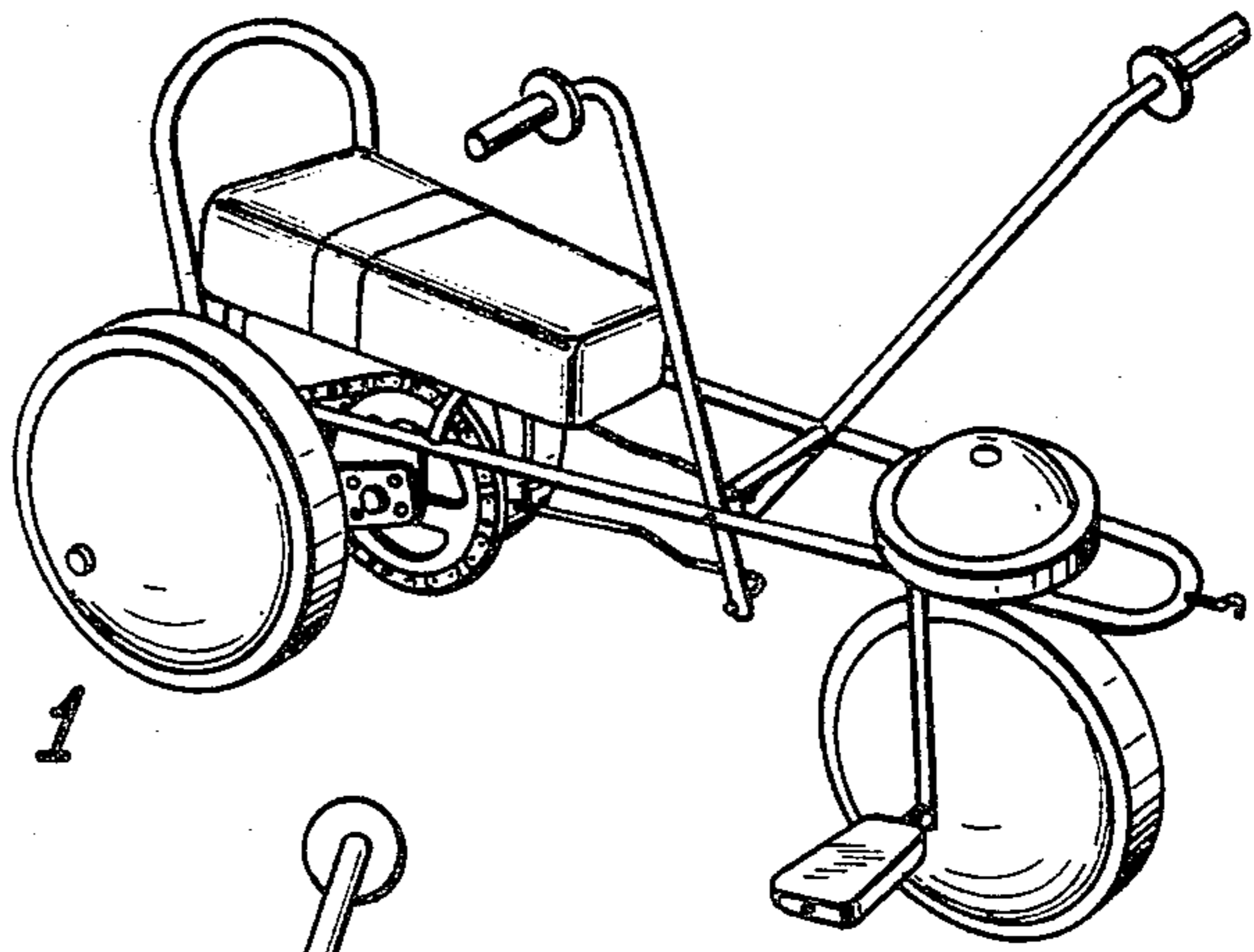

FIG. 1

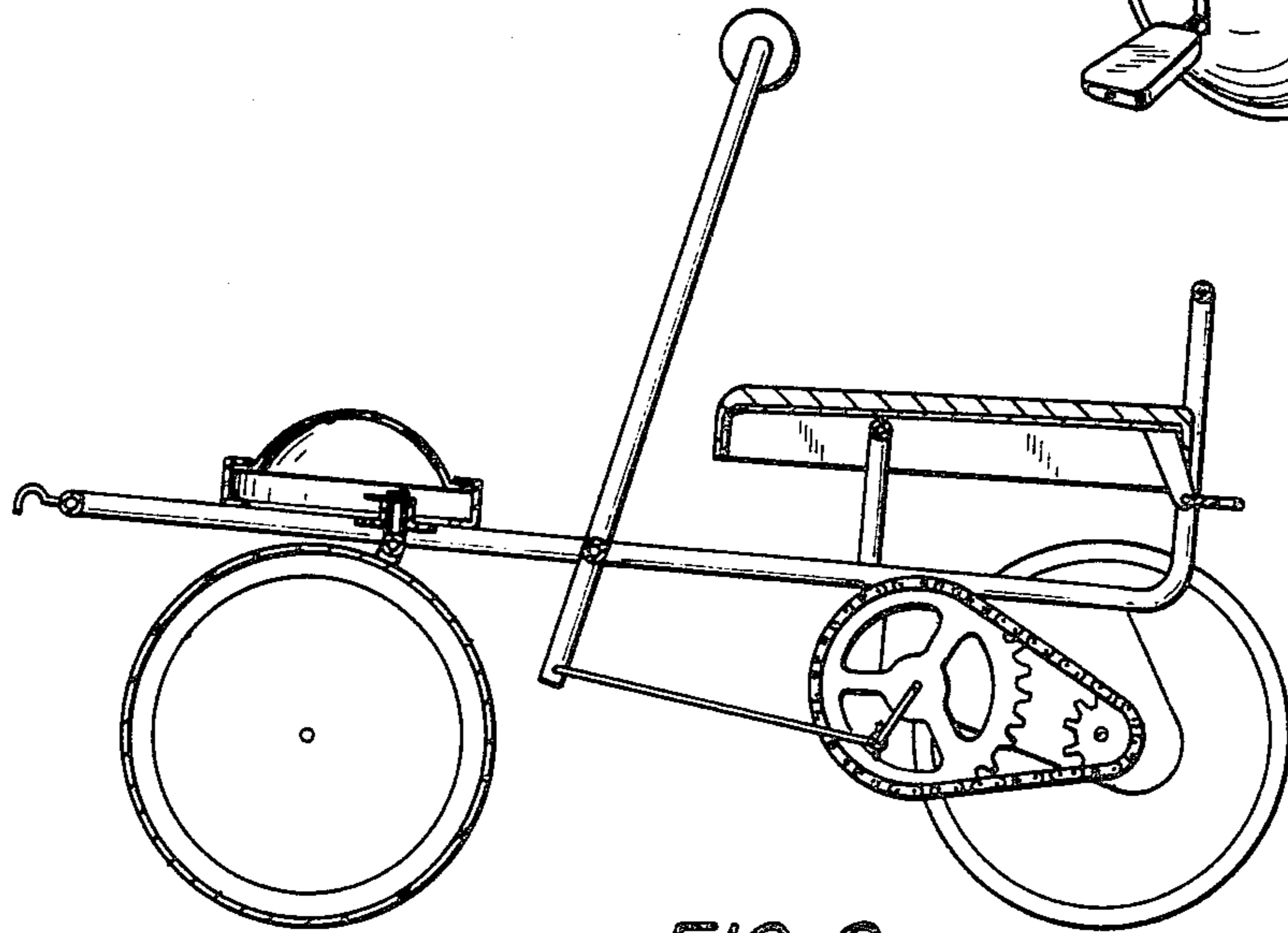

FIG. 8

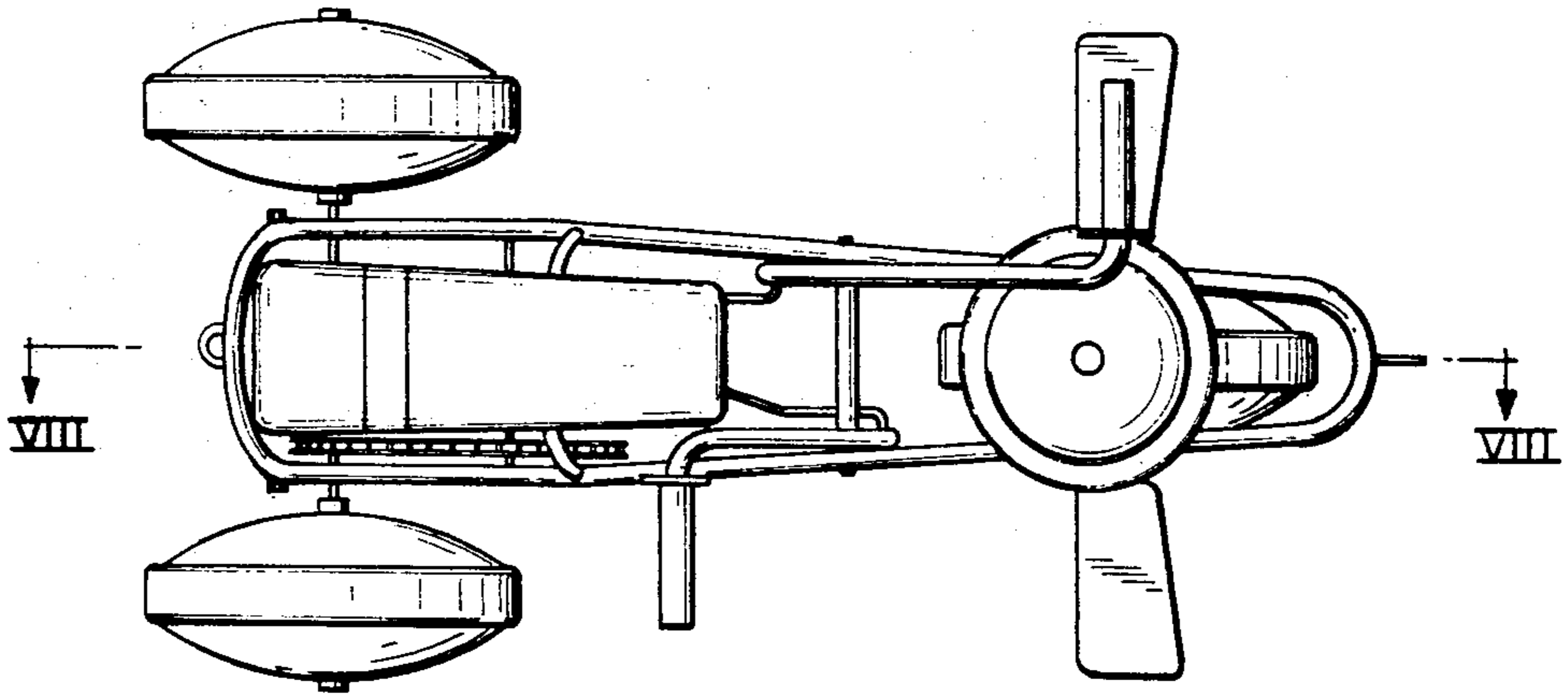

FIG. 2

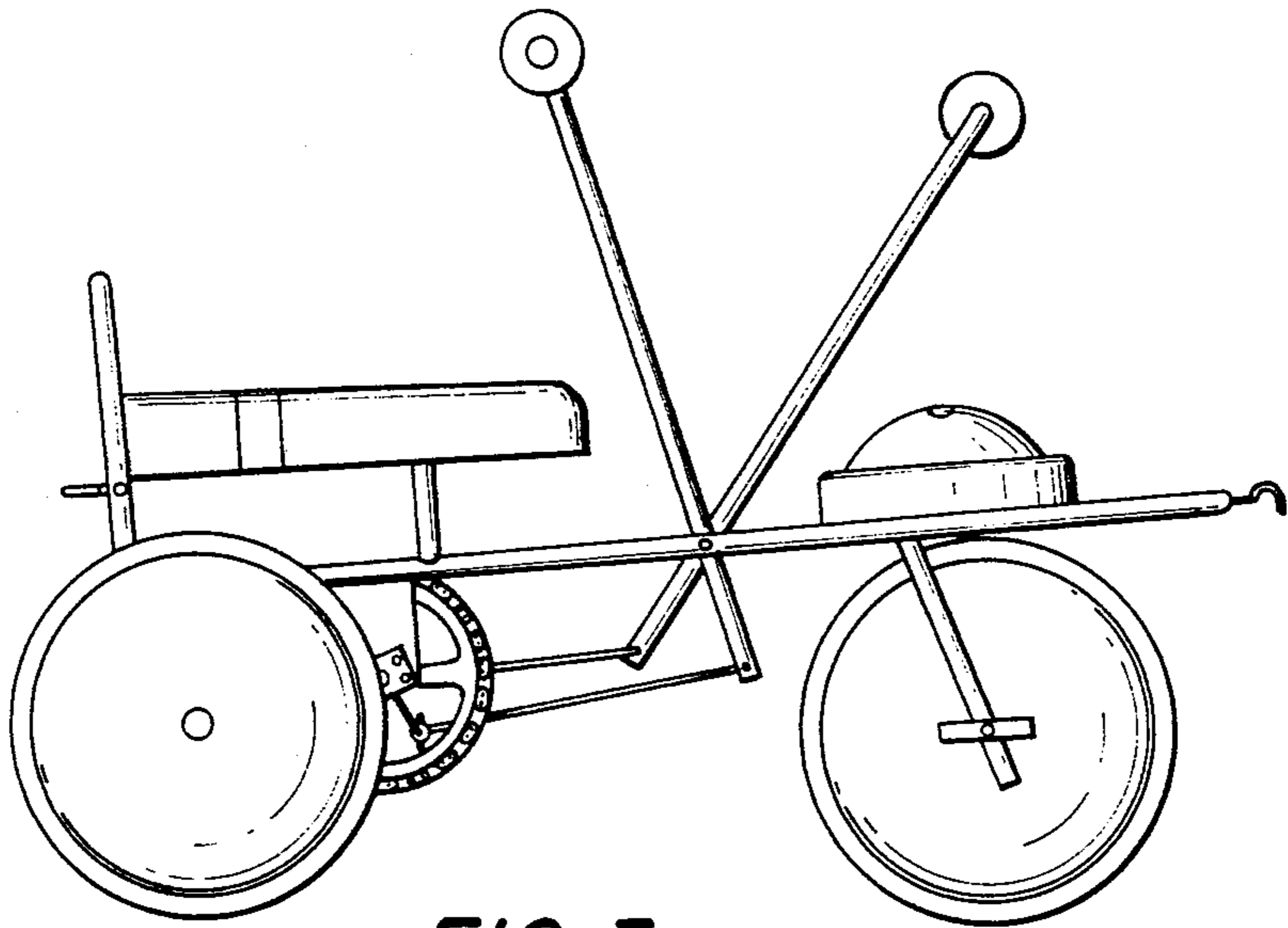

FIG. 3

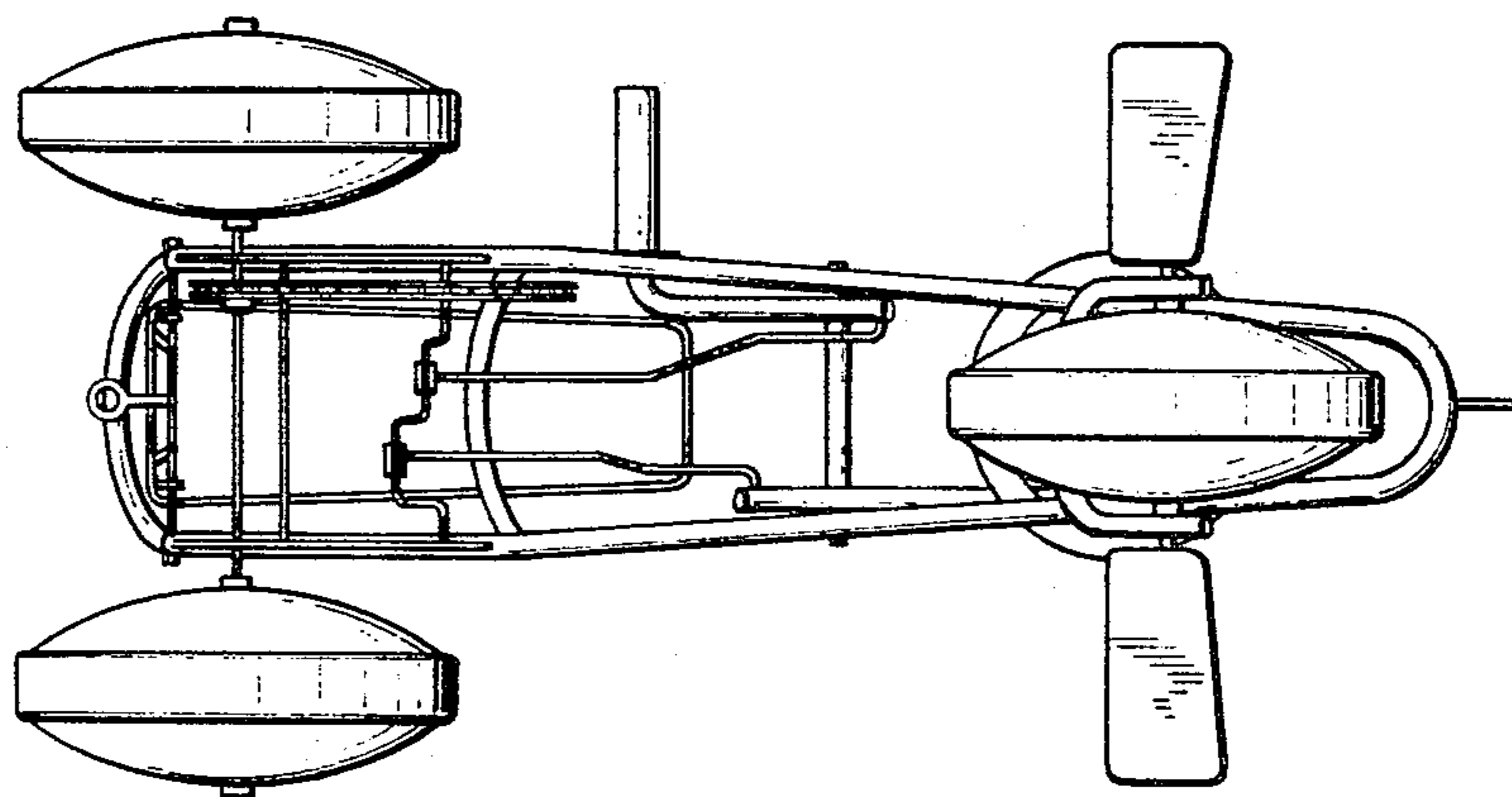

FIG. 4

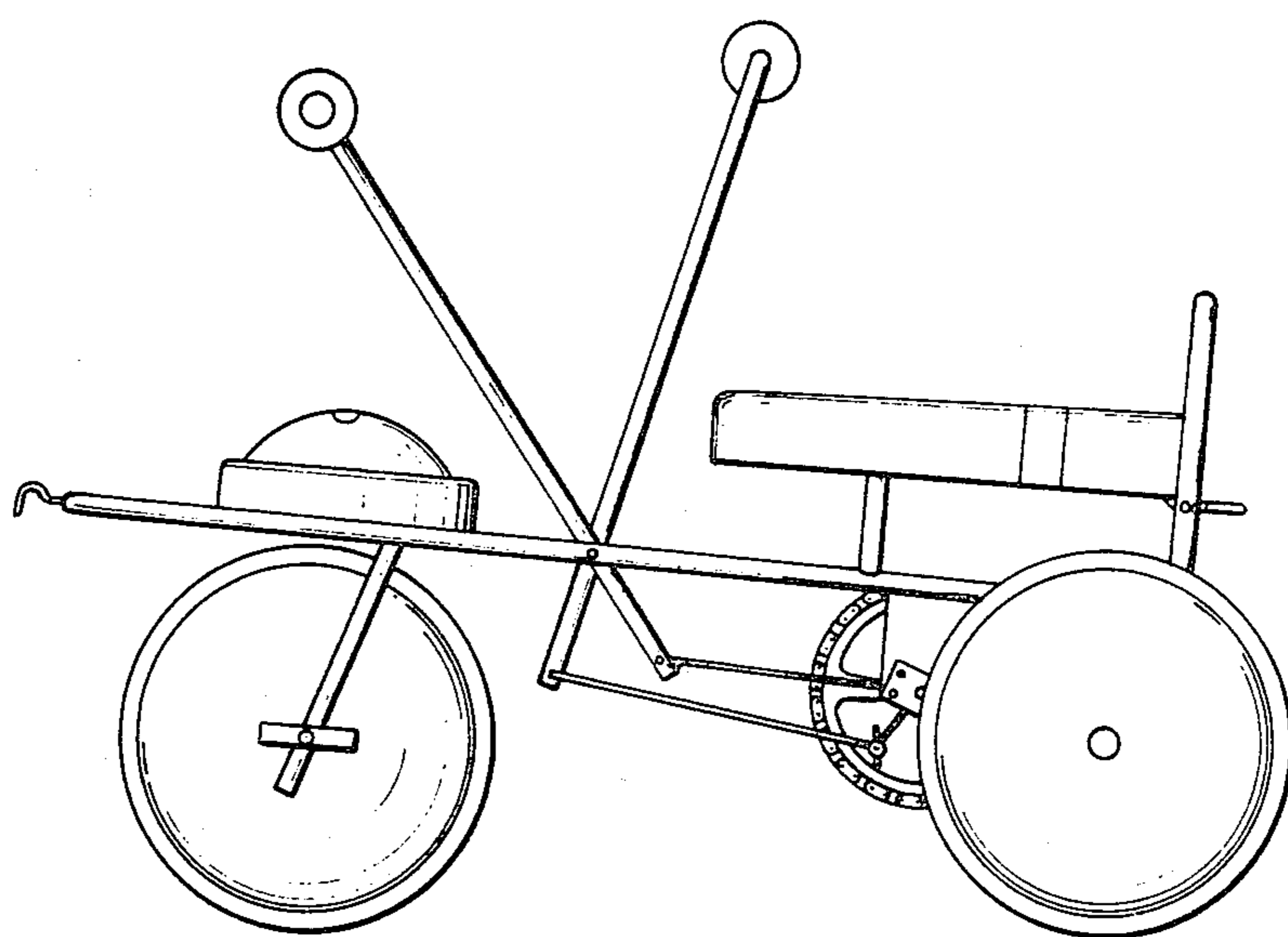
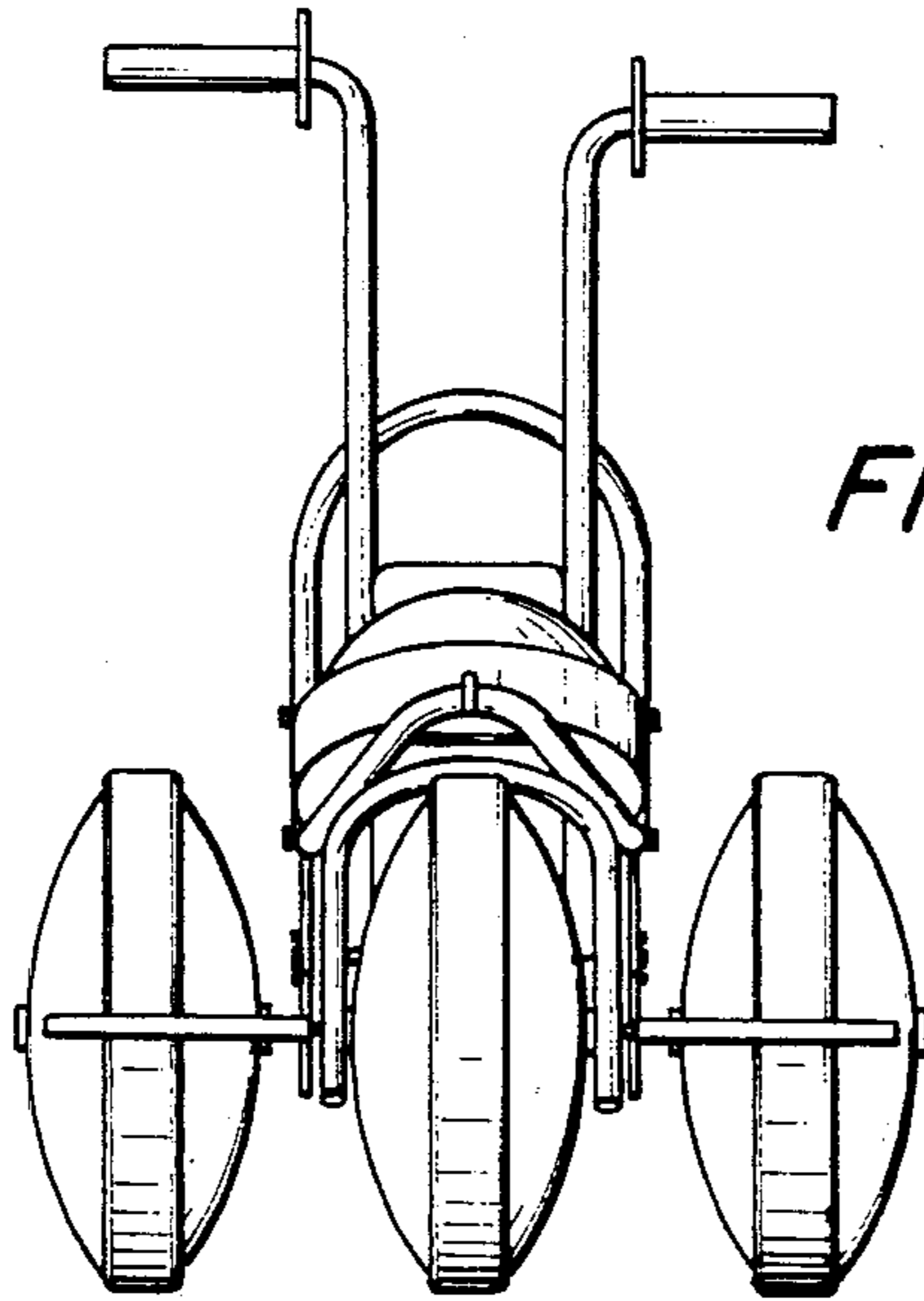
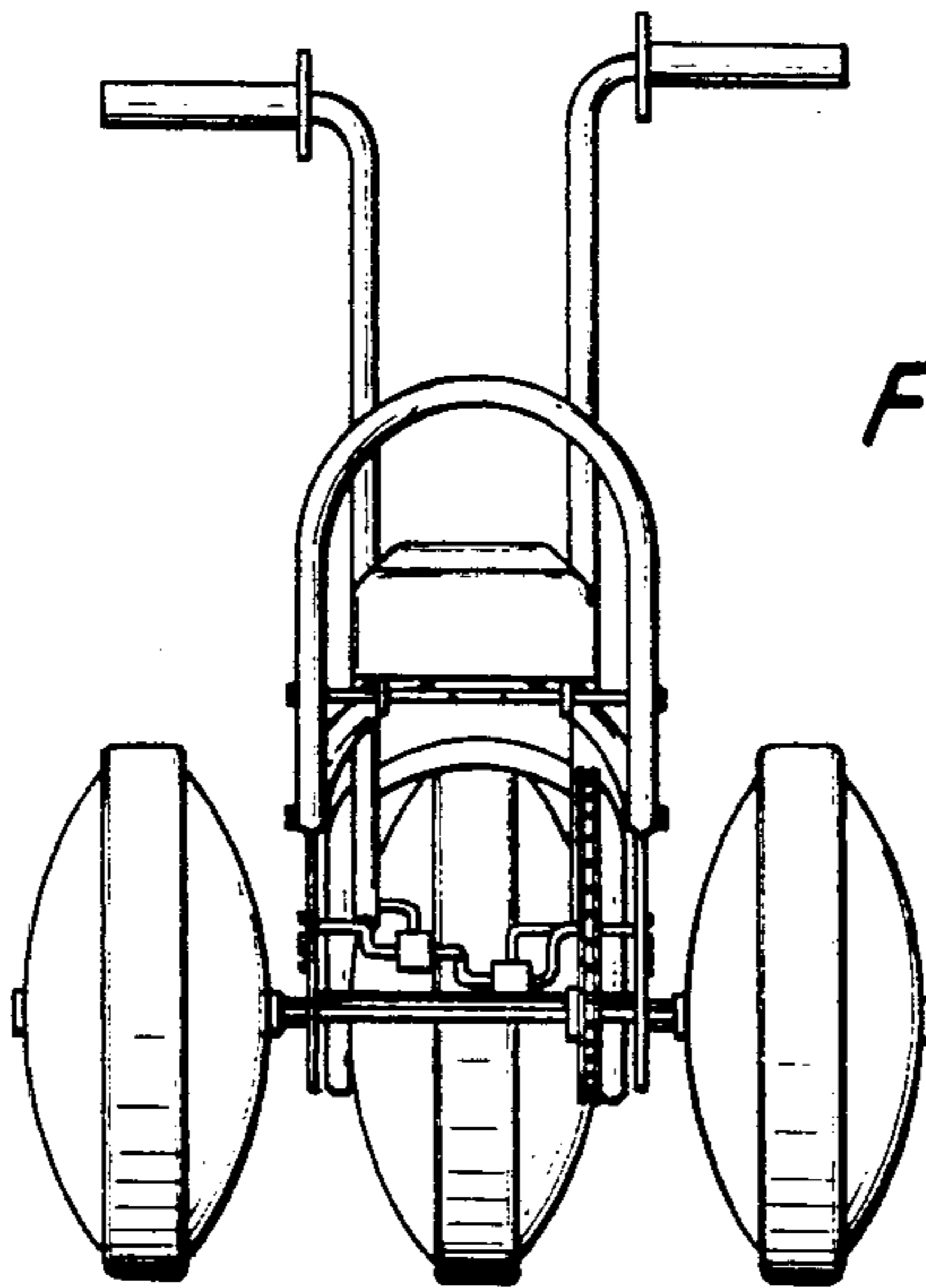

FIG. 5



*FIG. 6*



*FIG. 7*