

[54] WALL BOARD CLAMP

[75] Inventor: Randolph R. Ruetsch, Green Brook, N.J.

[73] Assignee: Thomas & Betts Corporation, Raritan, N.J.

[**] Term: 14 Years

[21] Appl. No.: 364,581

[22] Filed: Apr. 1, 1982

[52] U.S. Cl. D8/396; D8/382; D8/394

[58] Field of Search D8/382, 394-396; 24/454, 514, 522; 248/74.5

[56] References Cited

U.S. PATENT DOCUMENTS

3,568,262 3/1971 Woldman 24/73

OTHER PUBLICATIONS

Legrand-Elektro-Installations Material-Schalt-schränke-1973/Bandschellen-System. Colson-German.
T&B/Telecom-"T&B Has Lots of Little Ideas to Save You Big Money", Oct. 6, 1980.

T&B/Telecom "Wall-Banger" Cable Tie TC210; 10/6/1980.

Primary Examiner—B. J. Bullock

Attorney, Agent, or Firm—Robert M. Rodrick; Salvatore J. Abbruzzese

[57] CLAIM

The ornamental design for a wall board clamp, substantially as shown and described.

DESCRIPTION

FIG. 1 is a front perspective view of a wall board clamp showing my new design;

FIG. 2 is a front elevational view thereof, the portions of a wall and cable being shown in broken lines for illustrative purposes only;

FIG. 3 is a side elevational view taken from the left of FIG. 2;

FIG. 4 is a side elevational view taken from the right of FIG. 2;

FIG. 5 is a sectional view taken the direction of the arrows on line 5—5 of FIG. 2;

FIG. 6 is a rear elevational view thereof;

FIG. 7 is a sectional view taken in the direction of the arrows on line 7—7 of FIG. 3.

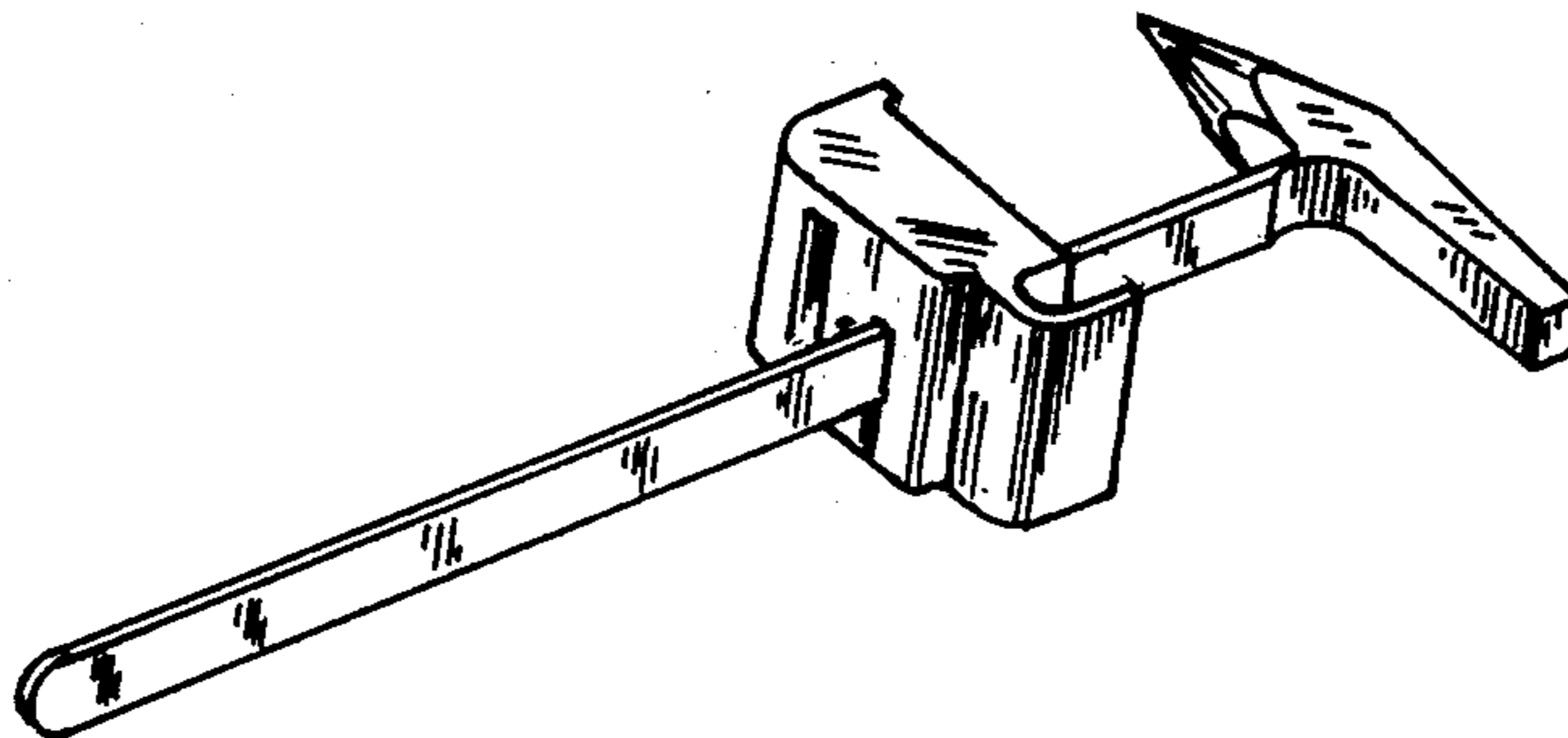

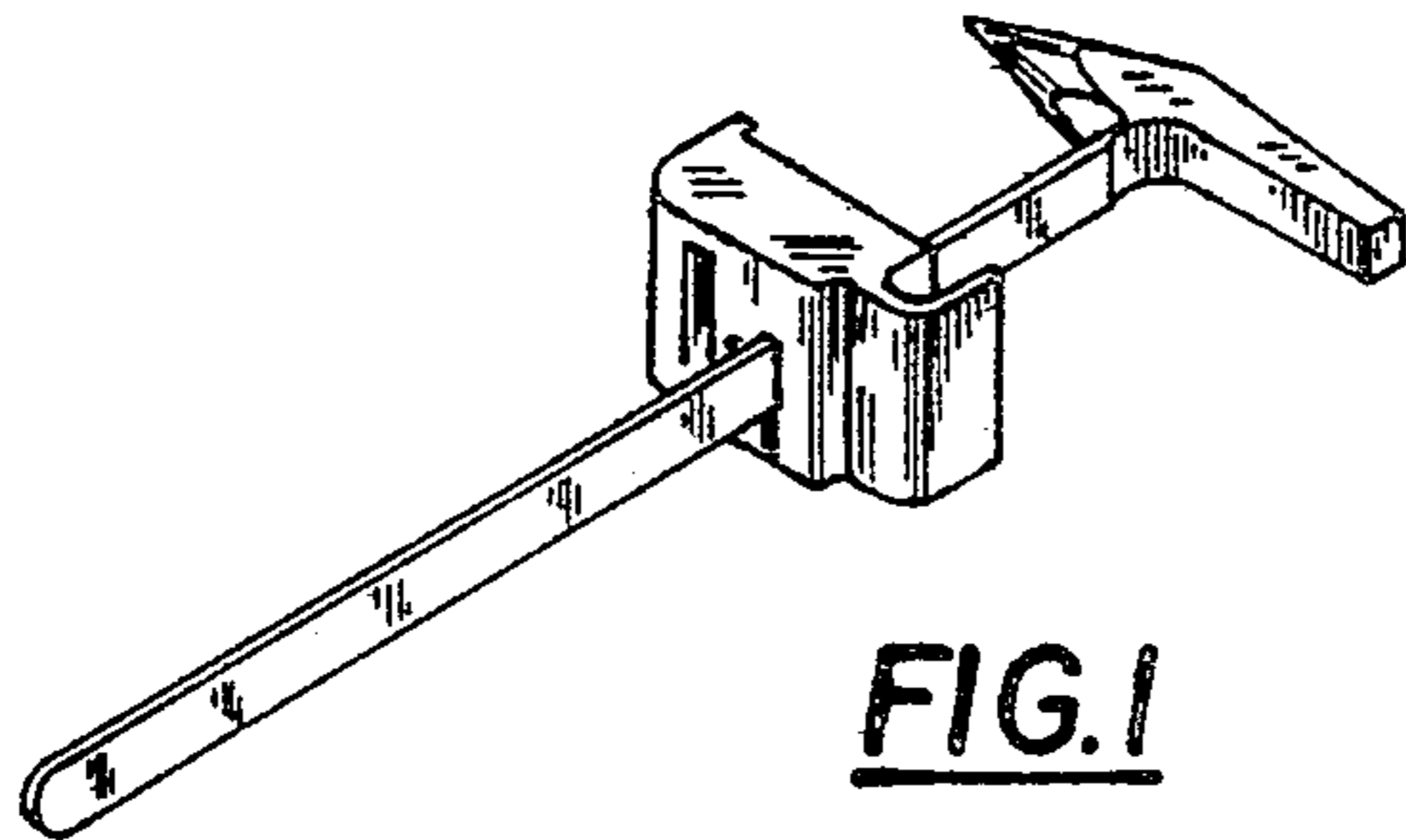

FIG. 1

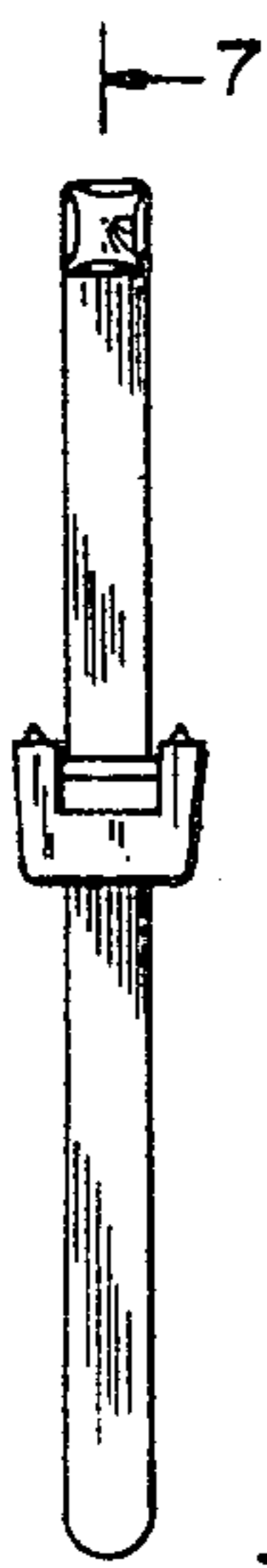

FIG. 3

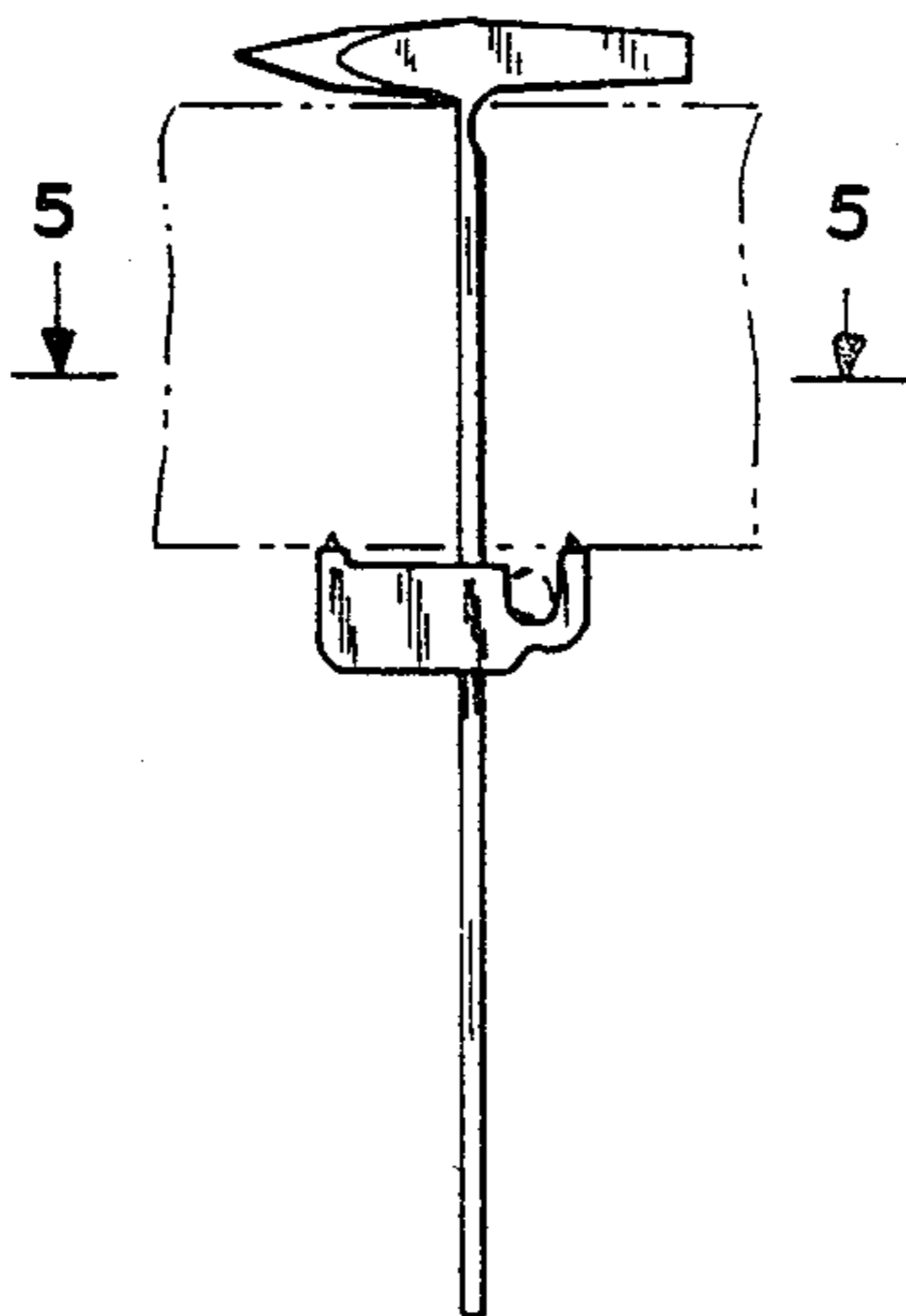

FIG. 2



FIG. 4

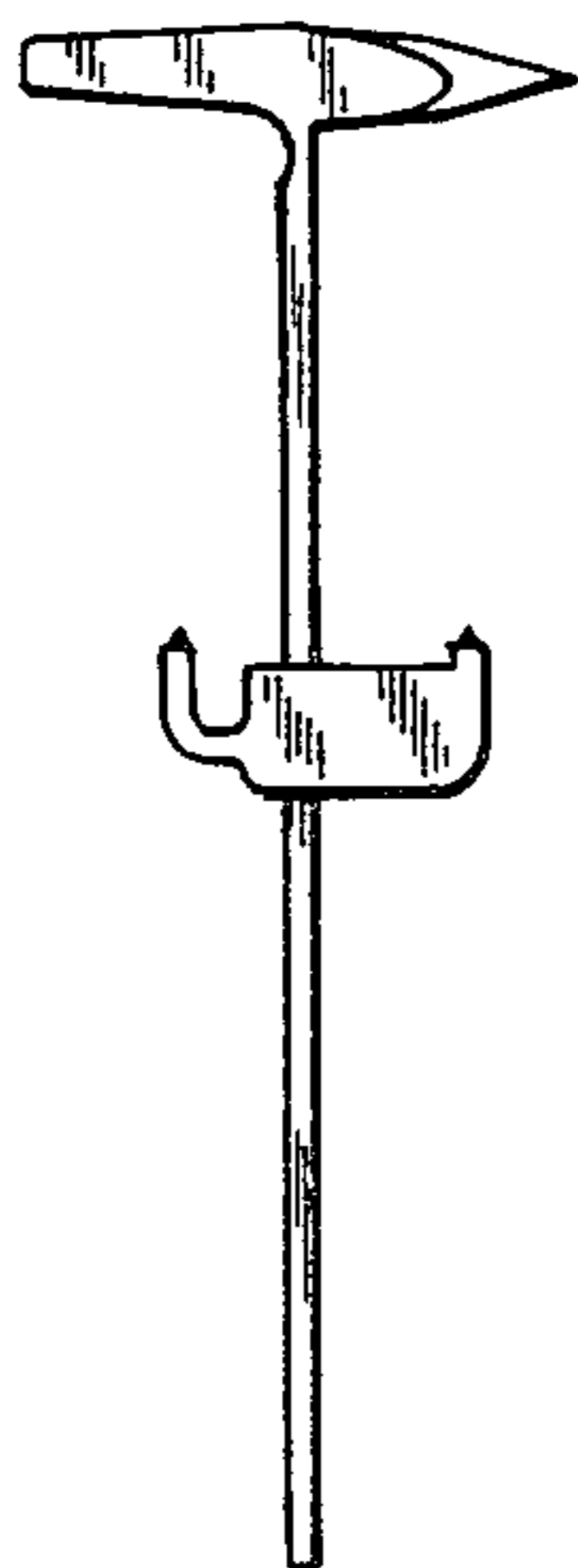

FIG. 6

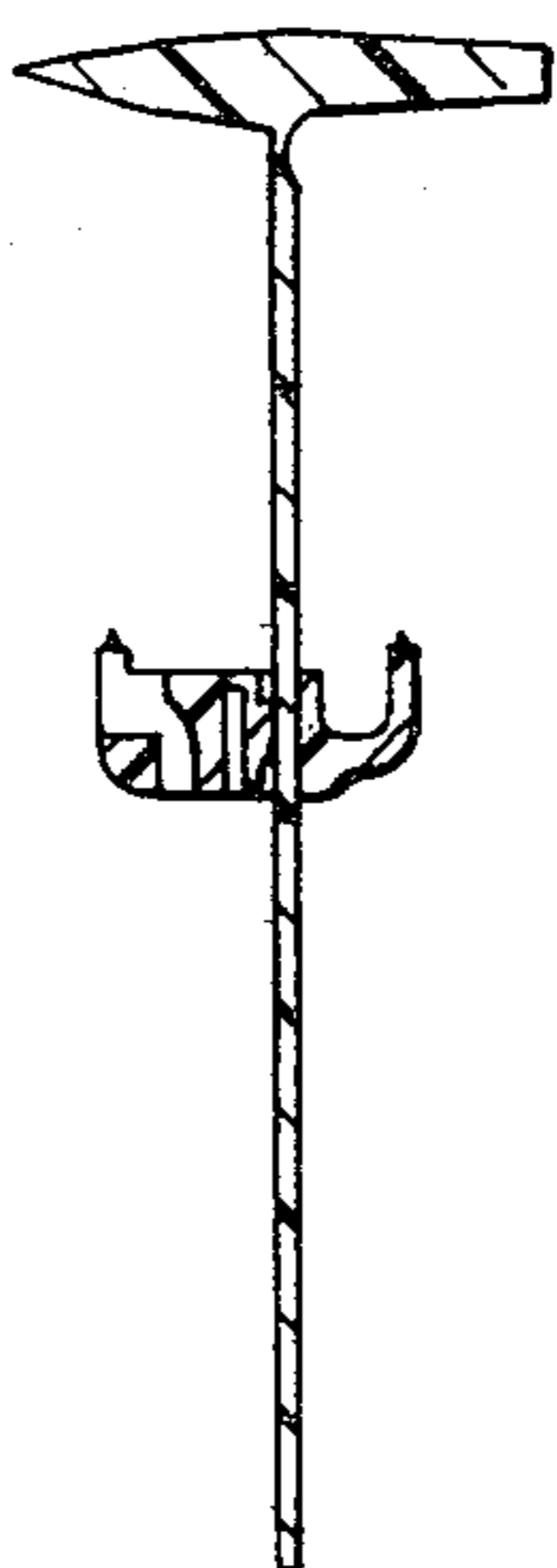

FIG. 7



FIG. 5