

[54] LATCH

[75] Inventor: Samuel S. Leotta, Jenkintown, Pa.

[73] Assignee: Southco, Inc., Concordville, Pa.

[**] Term: 14 Years

[21] Appl. No.: 503,885

[22] Filed: Jun. 13, 1983

[52] U.S. Cl. D8/331

[58] Field of Search D8/330, 331;
292/DIG. 38, 109, 256.69, 340

[56] References Cited

U.S. PATENT DOCUMENTS

2,829,912	4/1958	Koch	292/340
3,181,905	5/1965	Bisbing	292/109
3,466,076	9/1969	Bisbing	292/DIG. 38
3,602,121	8/1971	Ernisse	292/DIG. 38

3,709,538 1/1973 Seitz et al. 292/DIG. 38

Primary Examiner—B. J. Bullock
Assistant Examiner—Suzanne N. Gitlin
Attorney, Agent, or Firm—Paul & Paul

[57] CLAIM

The ornamental design for a latch, as shown.

DESCRIPTION

FIG. 1 is a reduced perspective view of a latch showing my new design;
FIG. 2 is a top plan view thereof;
FIG. 3 is a side elevational view taken from the bottom of FIG. 2;
FIG. 4 is a bottom plan view thereof;
FIG. 5 is an end elevational view taken from the left of FIG. 1;
FIG. 6 is an end elevational view taken from the right of FIG. 1.

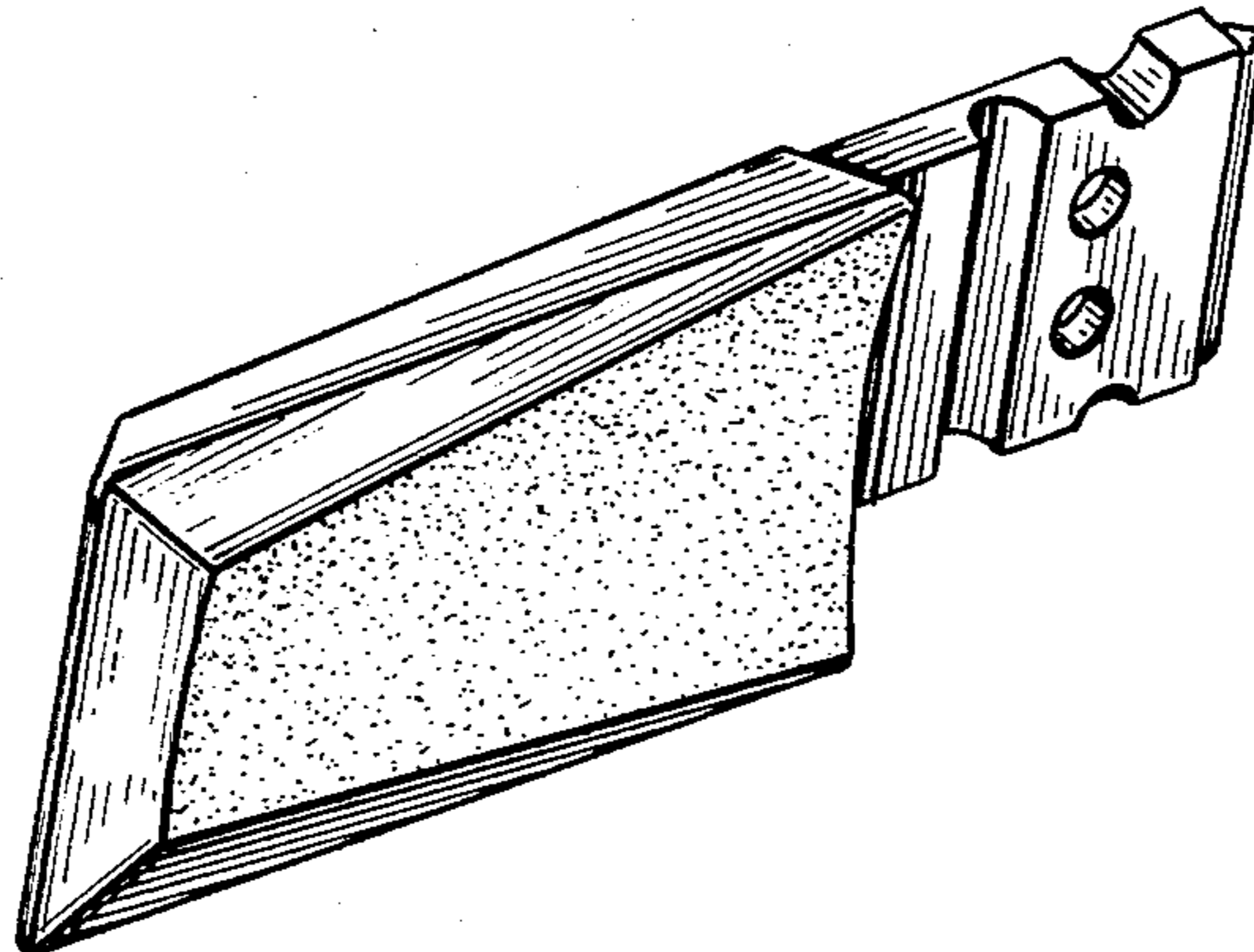

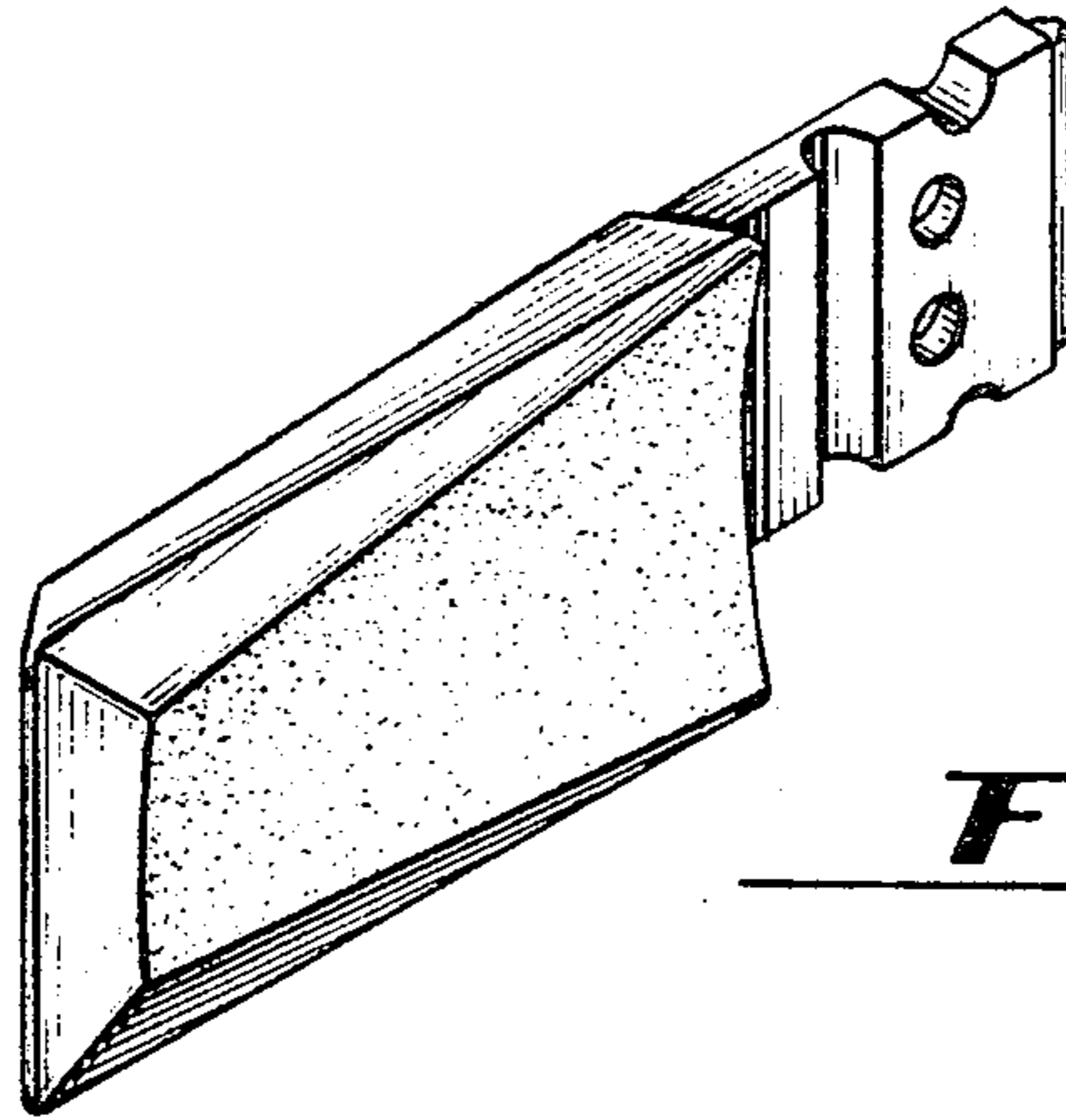

Fig. 1

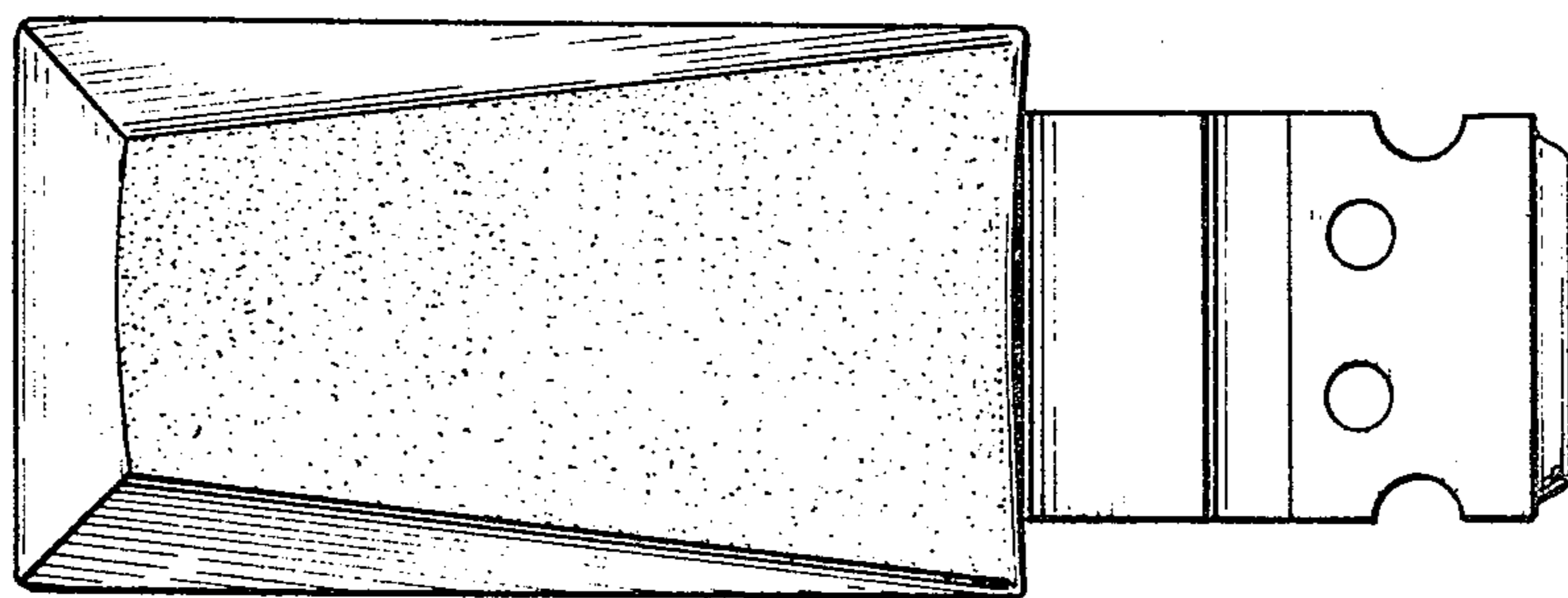

Fig. 2

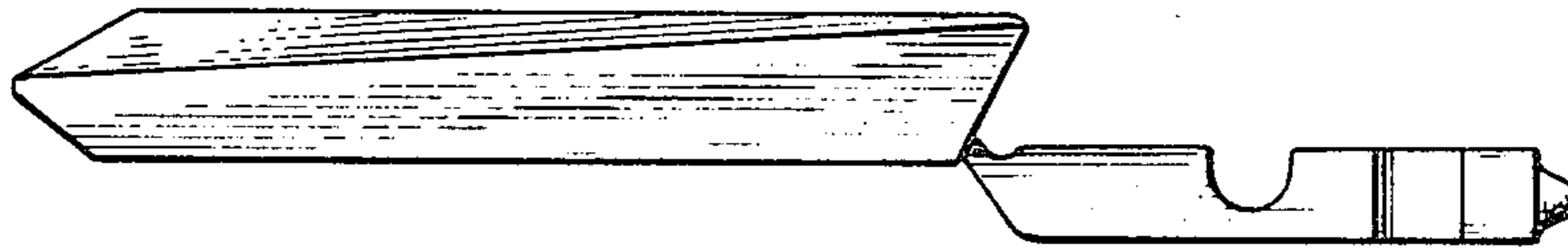

Fig. 3

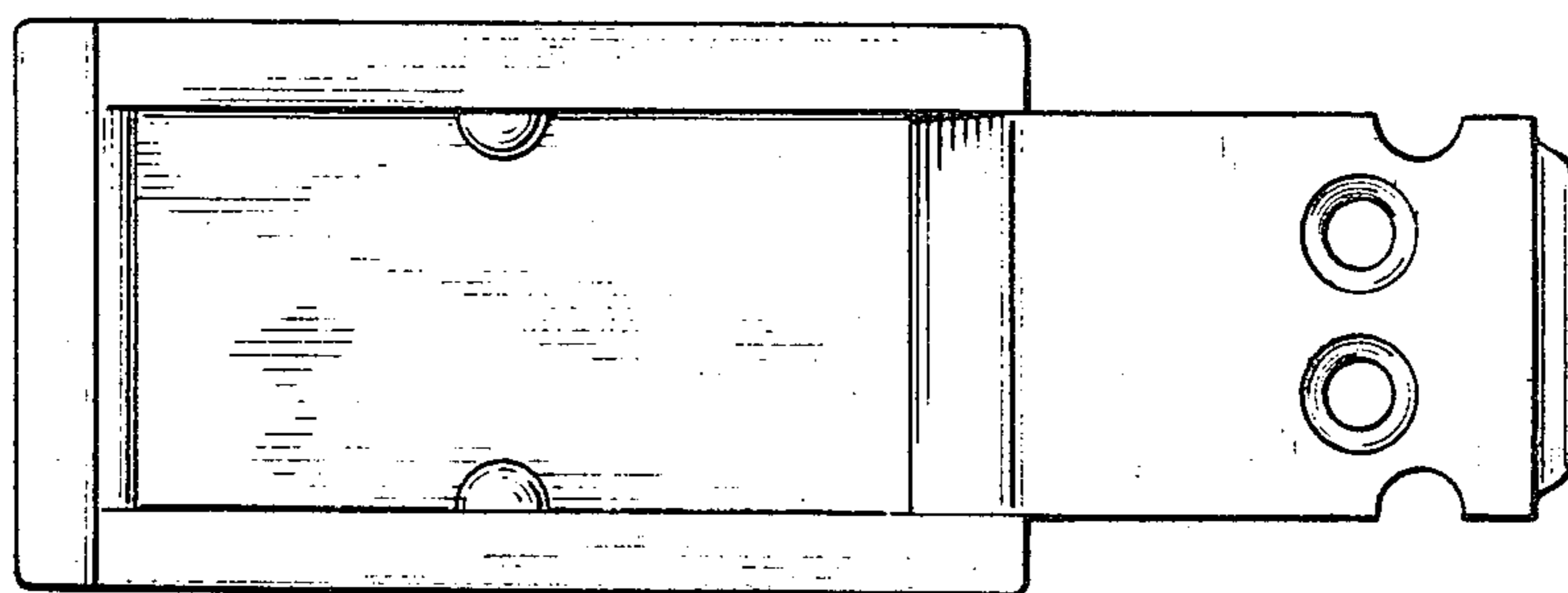

Fig. 4

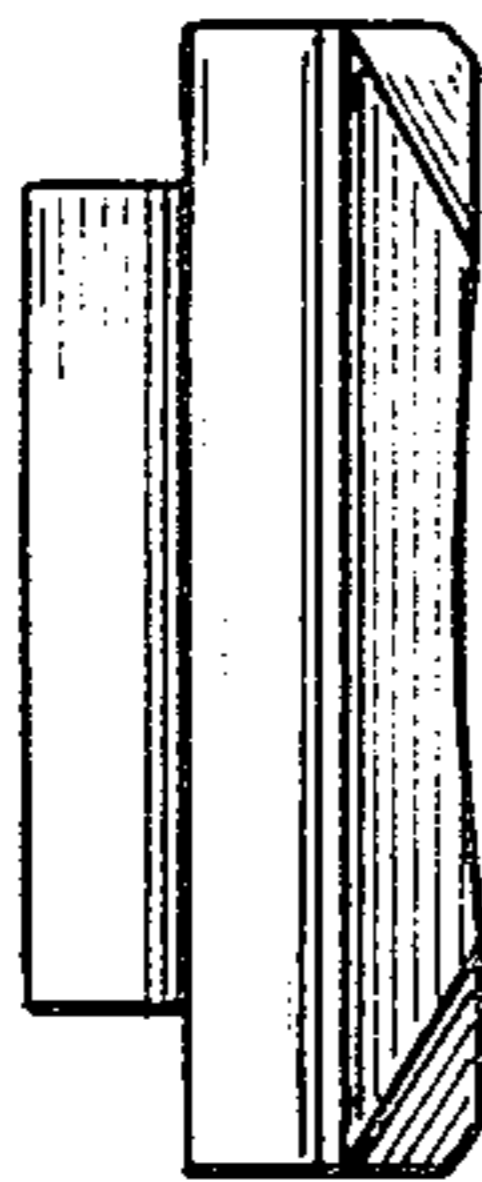

Fig. 5

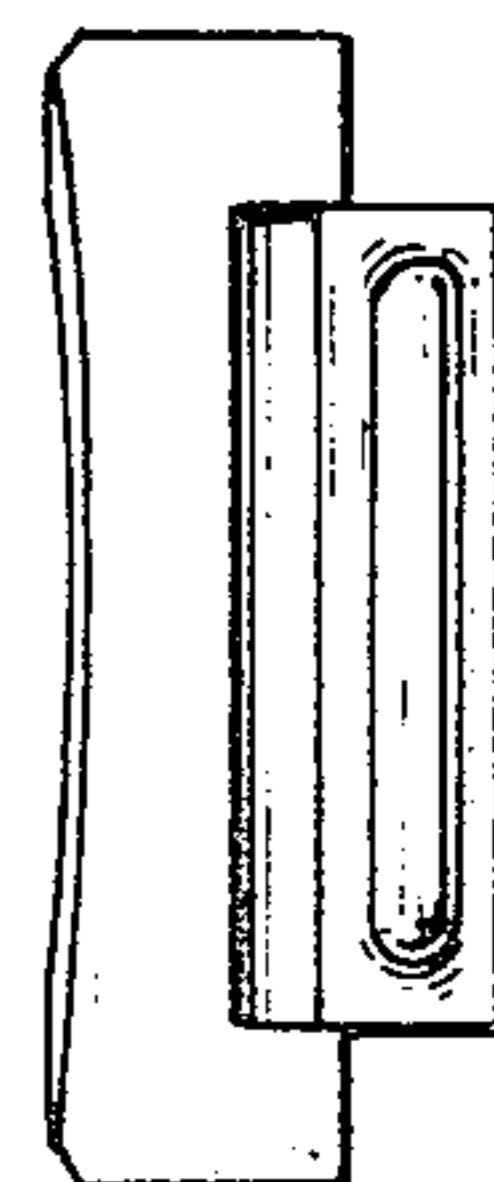

Fig. 6