

United States Patent [19]

Cake et al.

[11] Patent Number: **Des. 280,926**

[45] Date of Patent: **** Oct. 8, 1985**

[54] **COMBINED HYDROGEN IGNITOR AND HOUSING FOR WALL MOUNTING**

[75] Inventors: **Marcus P. Cake; Harry W. Falter,** both of Rocky Mount; **Clement W. Batchelor,** Spring Hope; **Michael A. Guarini,** Rocky Mount, all of N.C.

[73] Assignee: **Morrison-Knudsen Company, Inc.,** Boise, Id.

[**] Term: **14 Years**

[21] Appl. No.: **448,810**

[22] Filed: **Dec. 10, 1982**

[52] U.S. Cl. **D23/127**

[58] Field of Search 219/267, 262;
123/145 A; 361/264, 265, 266; D23/77, 129,
127, 130

[56] **References Cited**

U.S. PATENT DOCUMENTS

D. 256,949 9/1980 Patel D23/77 X
2,198,850 4/1940 White 123/145 A

2,967,224 1/1961 Irwin 361/266
3,412,290 11/1968 Hempson 219/262 X
3,744,955 7/1973 Tyler et al. 361/265 X
4,206,492 6/1980 Rhodes et al. 361/264

Primary Examiner—A. Hugo Word

Assistant Examiner—Stella Reid

Attorney, Agent, or Firm—Raymond N. Baker

[57] **CLAIM**

The ornamental design for a combined hydrogen ignitor and housing for wall mounting, substantially as shown and described.

DESCRIPTION

FIG. 1 is a front elevational view of a combined hydrogen ignitor and housing for wall mounting showing our new design;

FIG. 2 is a right-hand side elevational view of our new design;

FIG. 3 is a left-hand side elevational view of our new design;

FIG. 4 is a top plan view of our new design;

FIG. 5 is a rear elevational view of our new design, and FIG. 6 is a bottom plan view of our new design.

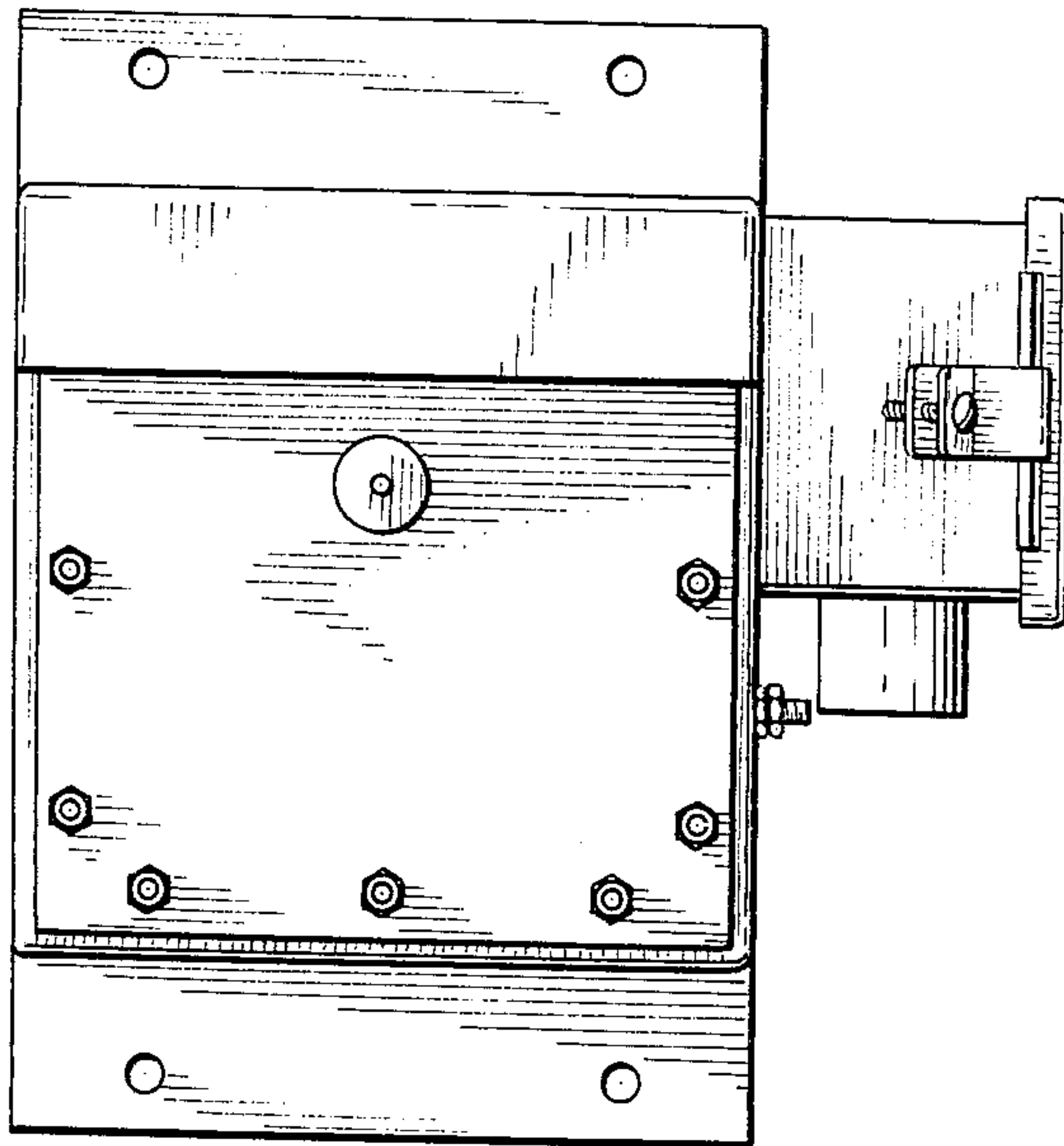

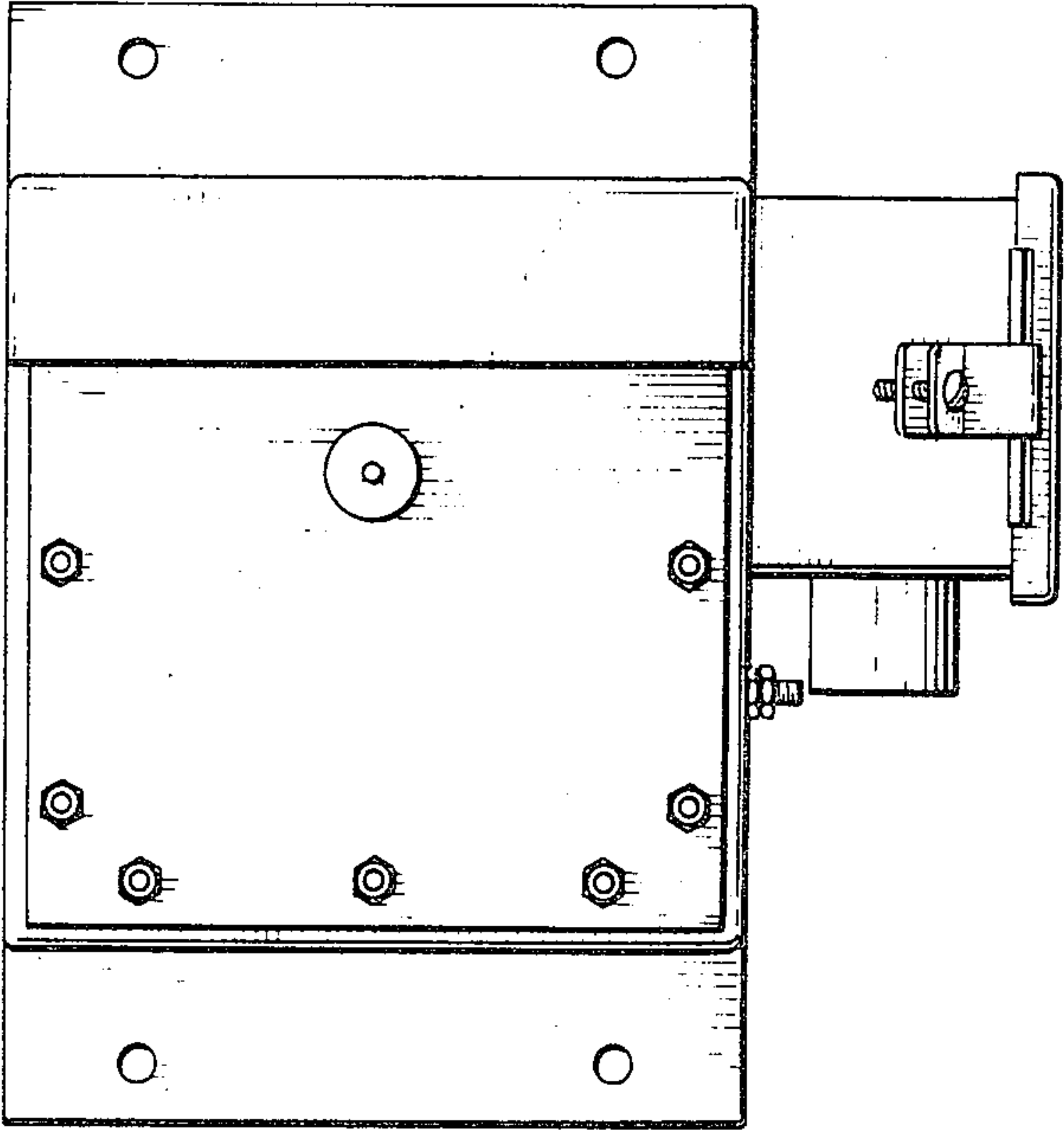

FIG. 1

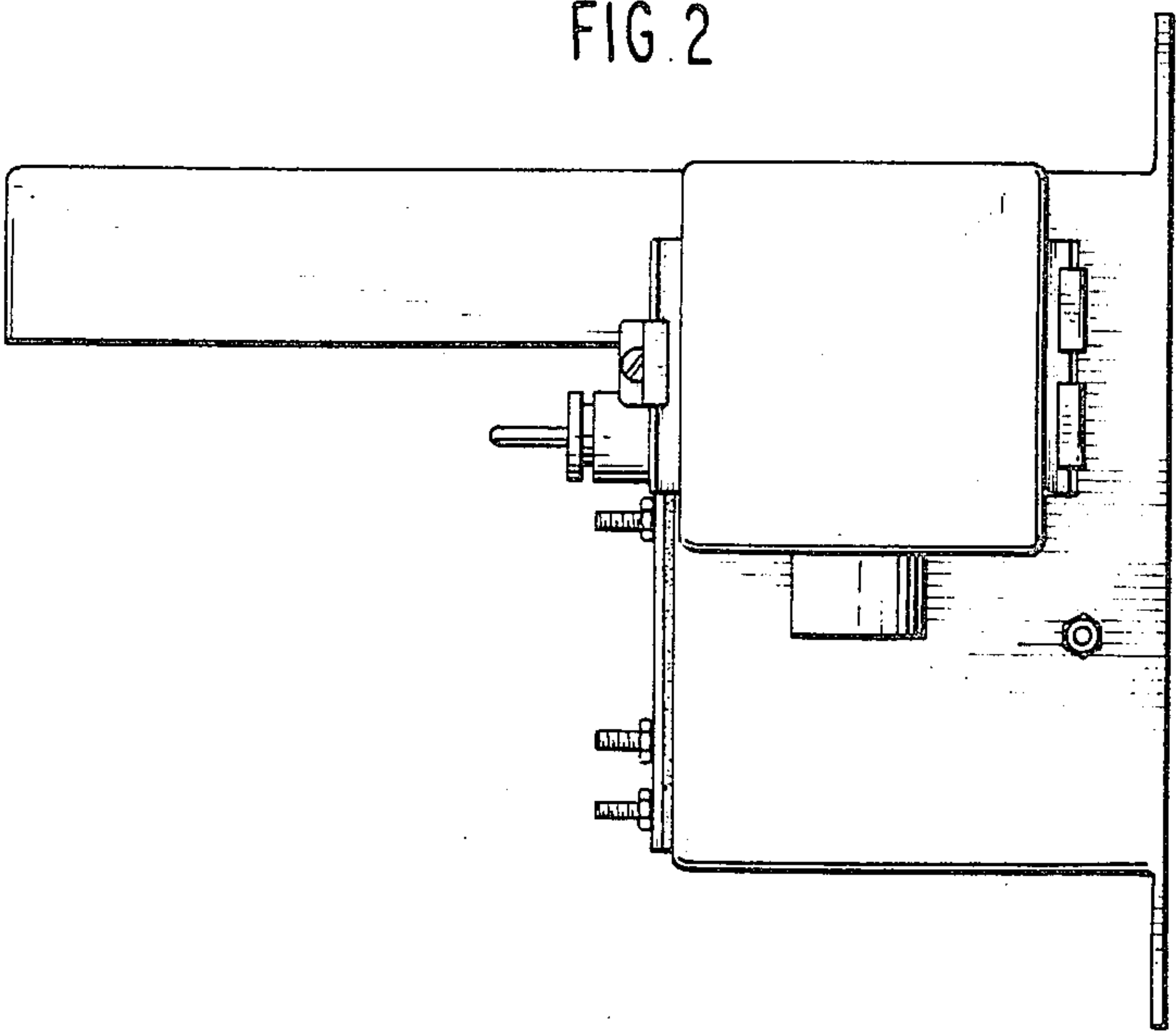

FIG. 2

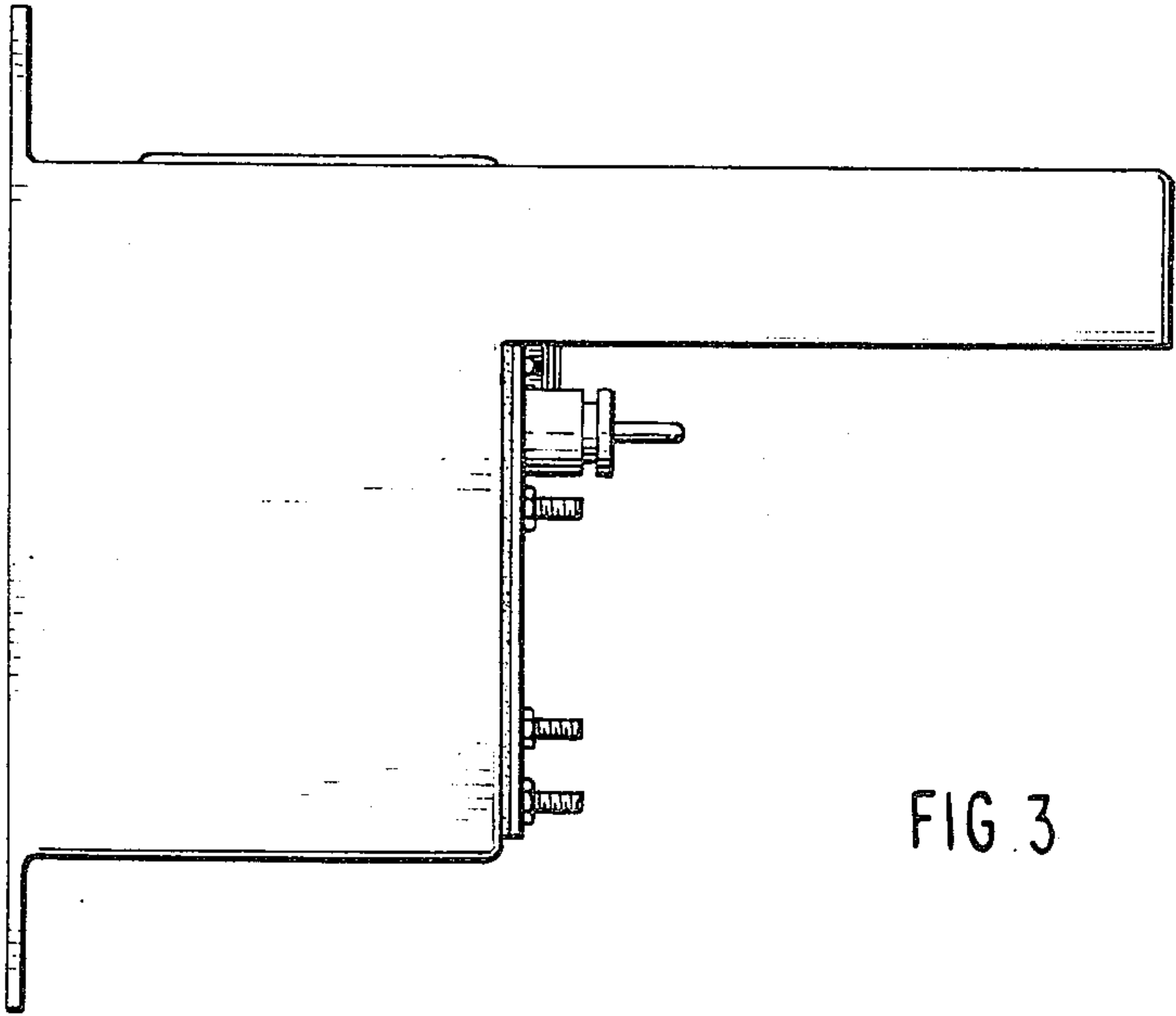

FIG. 3

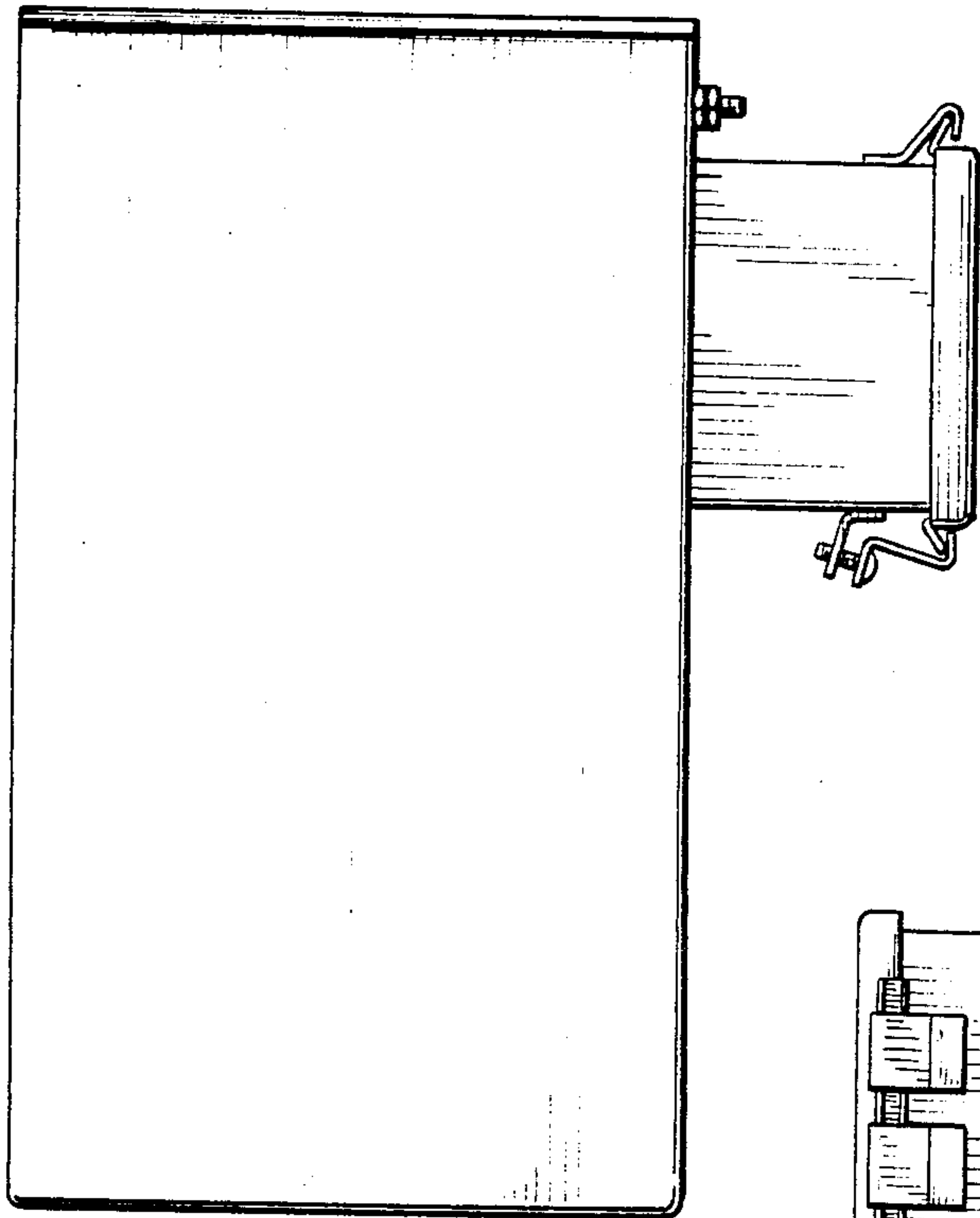

FIG. 4

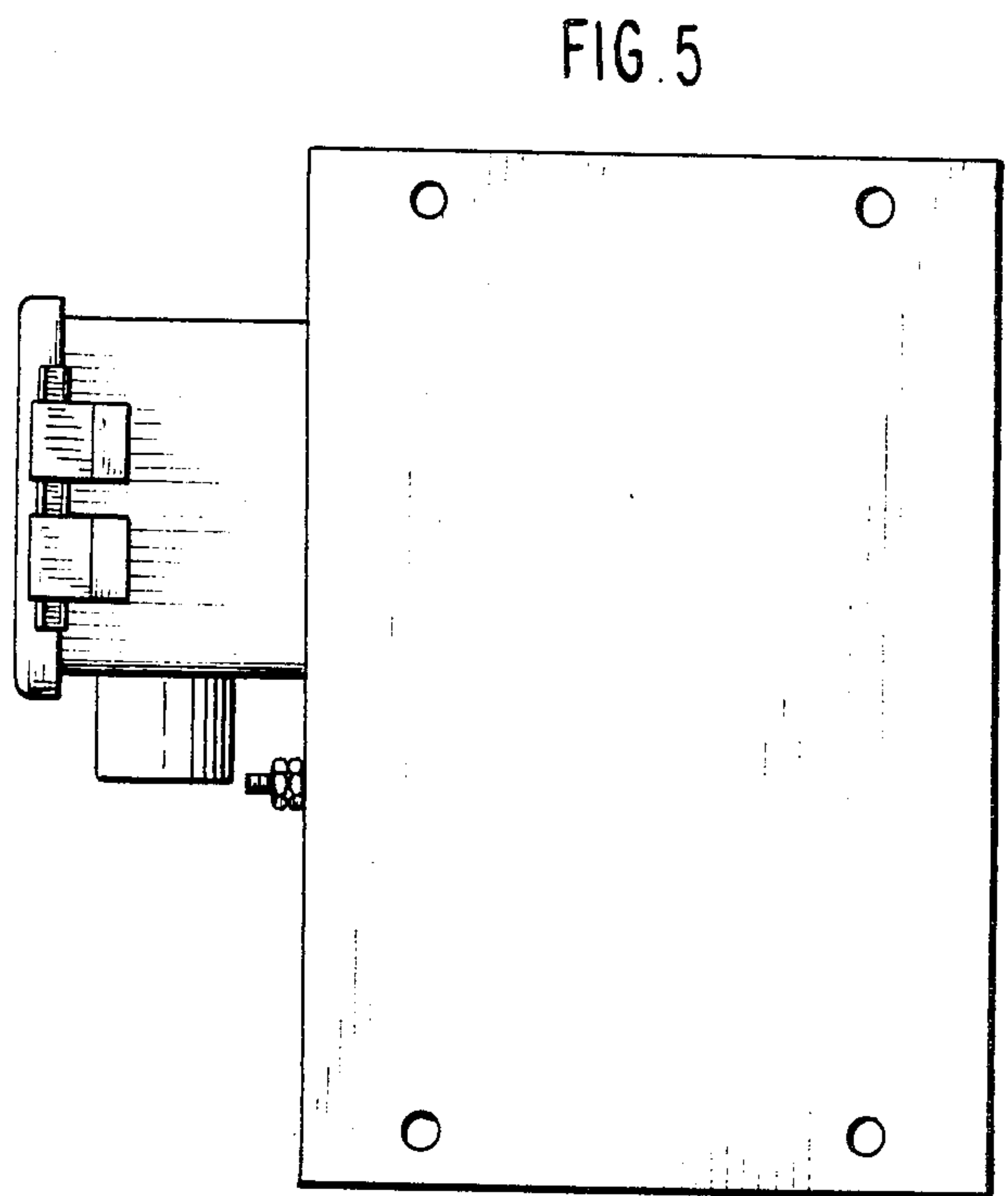

FIG. 5

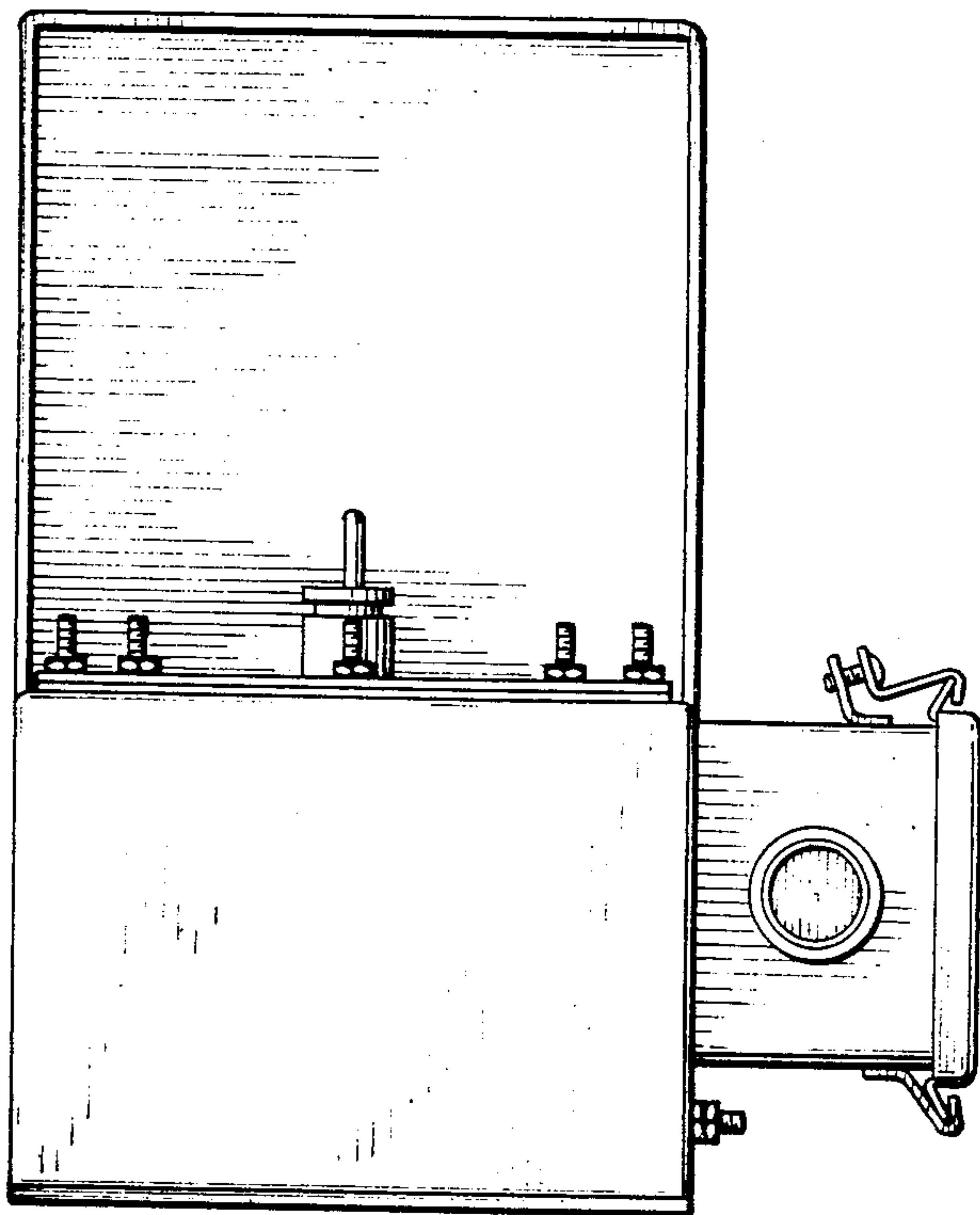

FIG. 6