

[54] TOY VEHICLE

[76] Inventor: Arthur M. Skolnik, 612-36th Ave., Seattle, Wash. 98122

[**] Term: 14 Years

[21] Appl. No.: 477,357

[22] Filed: Mar. 21, 1983

[52] U.S. Cl. D21/80

[58] Field of Search D21/80, 76, 78, 156; D12/112; 280/87.01, 220, 87.02 R, 87.03, 47.12

[56] References Cited

U.S. PATENT DOCUMENTS

D. 145,624	9/1946	Huebner	D34/15
D. 146,061	12/1946	Patner	D34/15
D. 178,619	8/1956	Tonelli	D34/15
D. 190,024	4/1961	Rouse	D21/78
D. 214,785	7/1969	Rypinski	D21/80
D. 222,283	10/1971	Reeves	D21/78

D. 244,479	5/1977	Pasin	D21/80
D. 256,035	7/1980	Lockhart	D21/81
1,267,050	5/1918	Brigel	D21/76
1,664,858	4/1928	Headley	.	
3,140,100	7/1964	Nichols et al.	280/87.04
4,071,261	1/1978	Winchell	280/220

Primary Examiner—Charles A. Rademaker
Attorney, Agent, or Firm—Finnegan, Henderson, Farabow, Garrett & Dunner

[57] CLAIM

The ornamental design for a toy vehicle, as shown.

DESCRIPTION

FIG. 1 is a perspective view of a toy vehicle showing my new design;
FIG. 2 is a rear elevational view thereof;
FIG. 3 is a side elevational view thereof;
FIG. 4 is a top plan view thereof;
FIG. 5 is bottom plan view thereof; and
FIG. 6 is a front elevational view thereof.

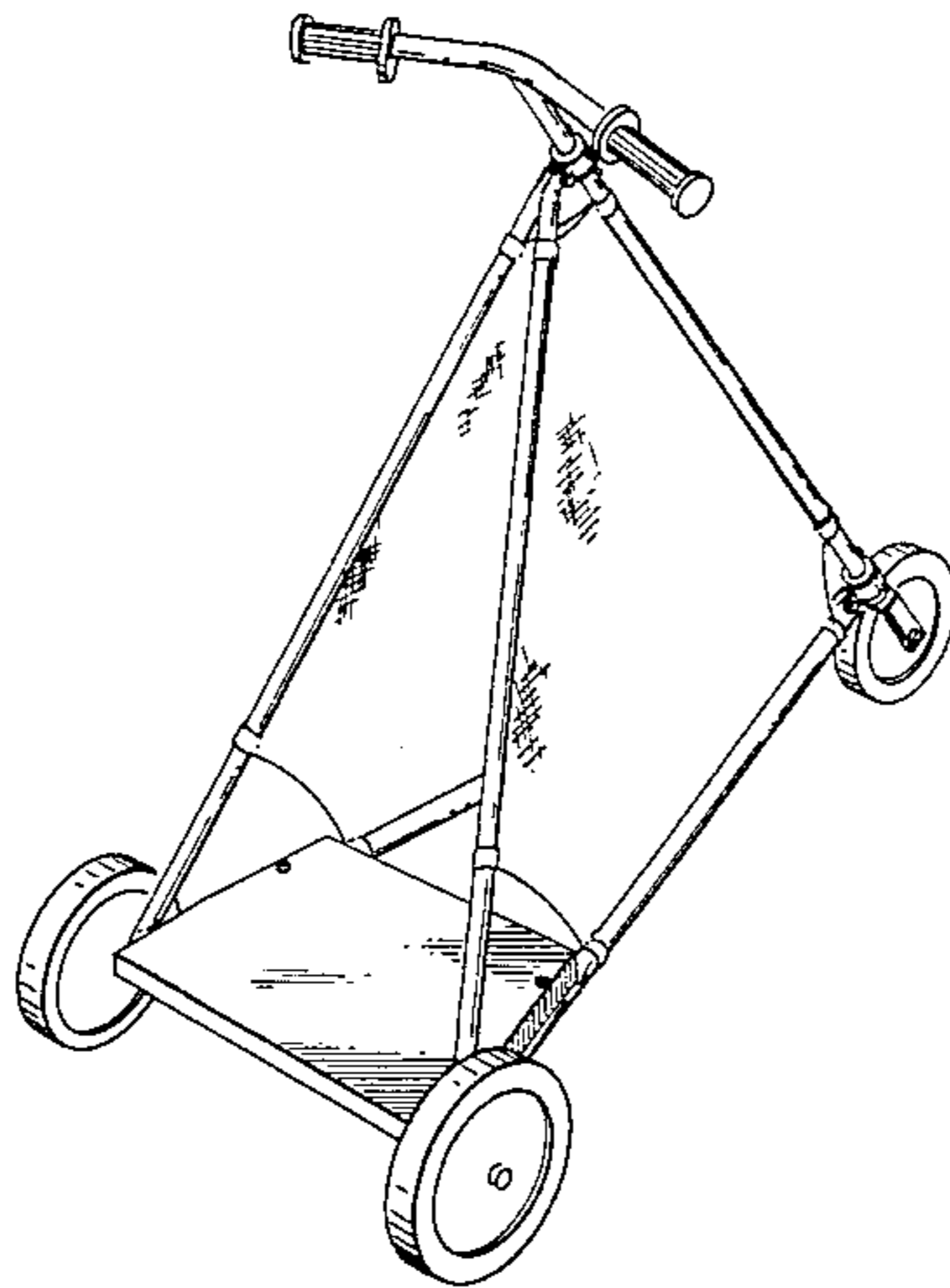

FIG. 1

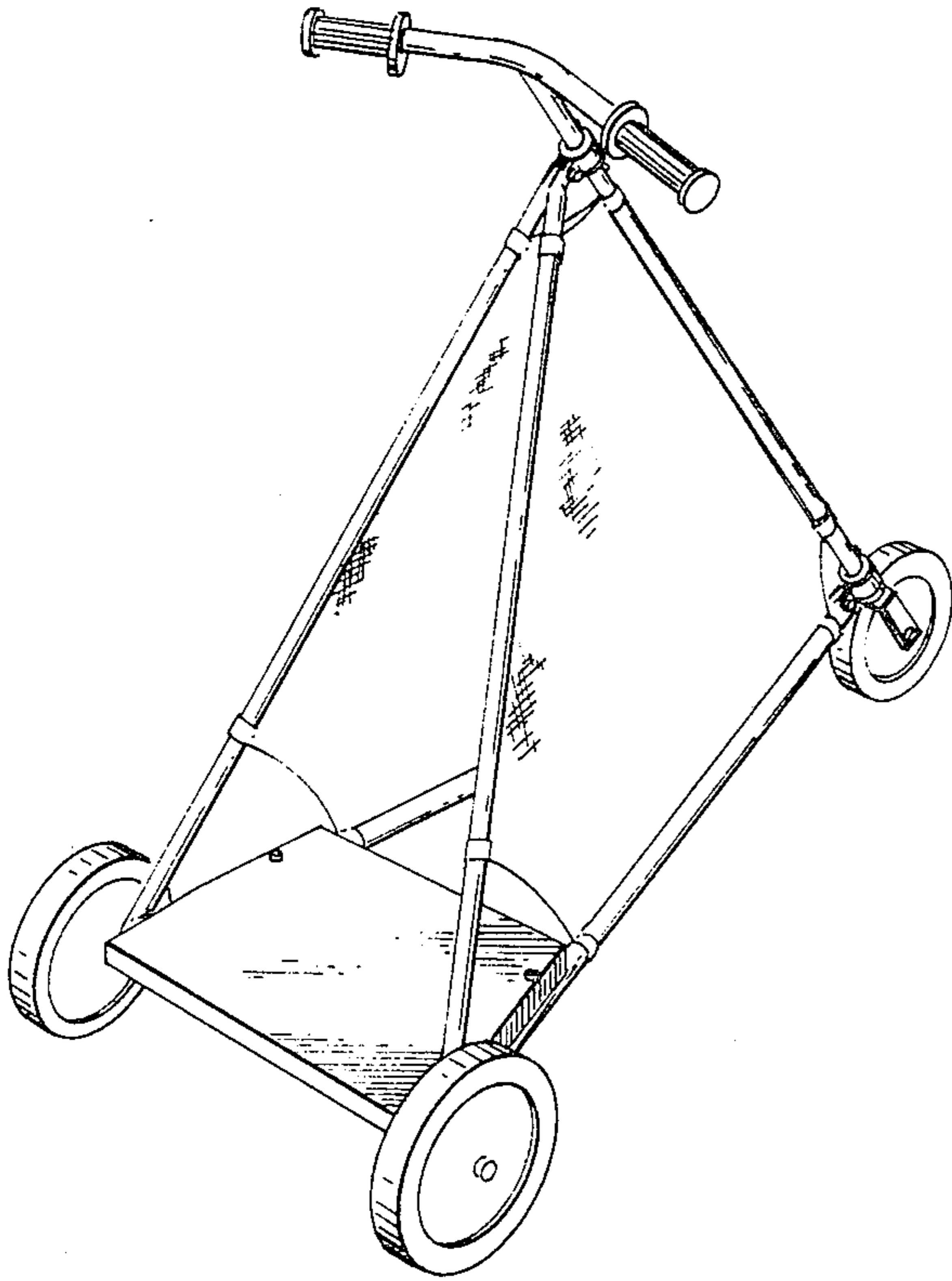

FIG. 2

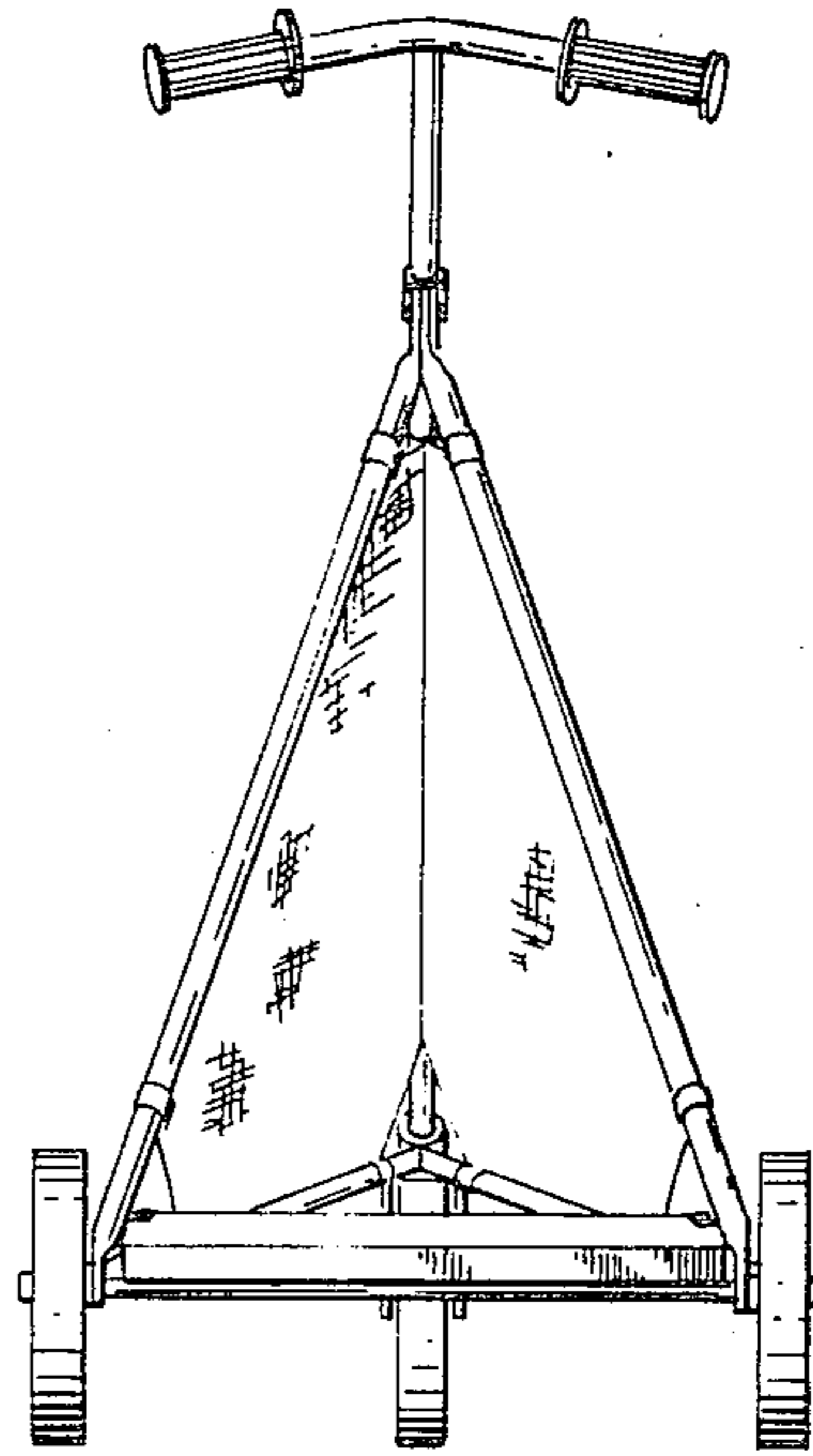

FIG. 3

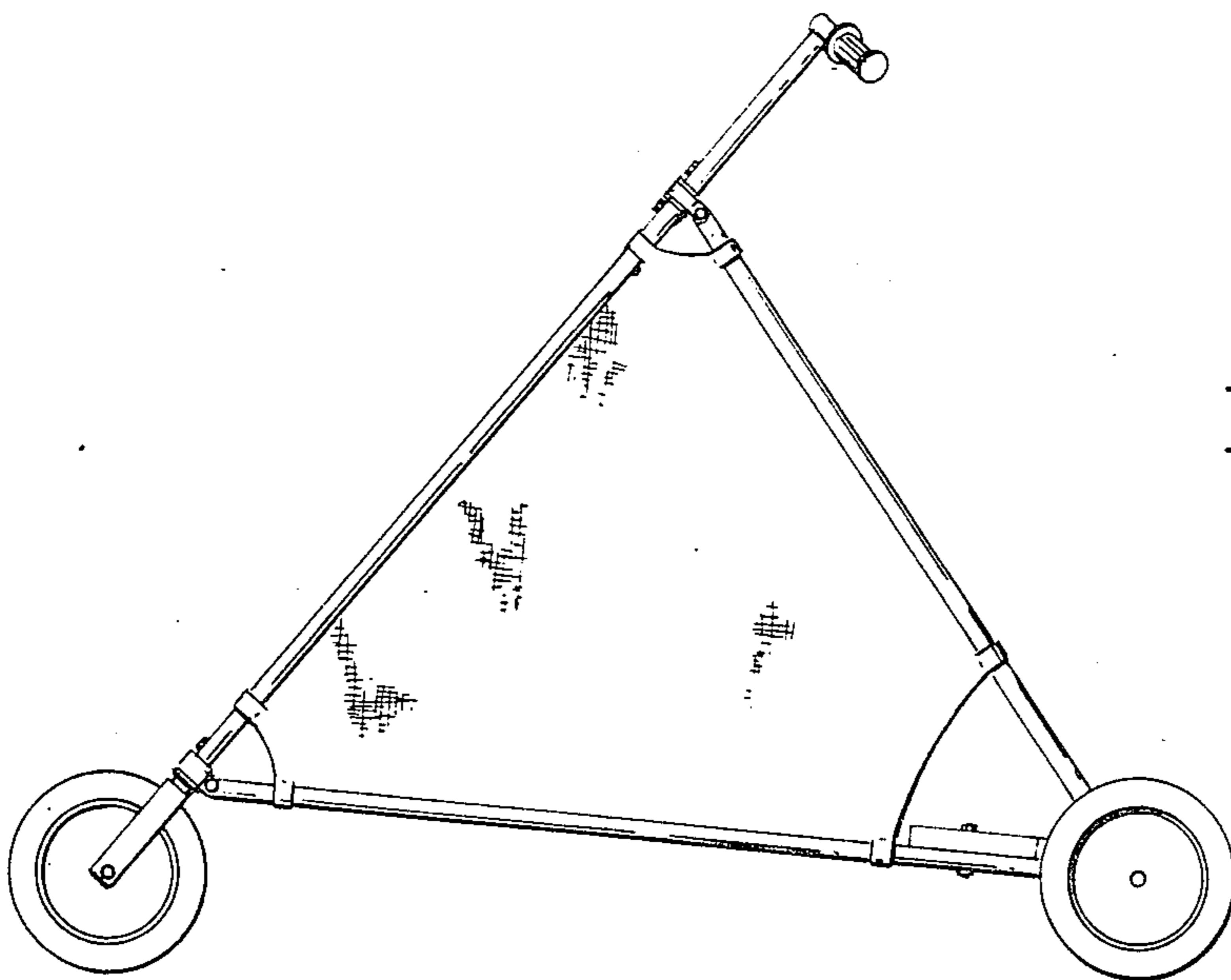

FIG. 4

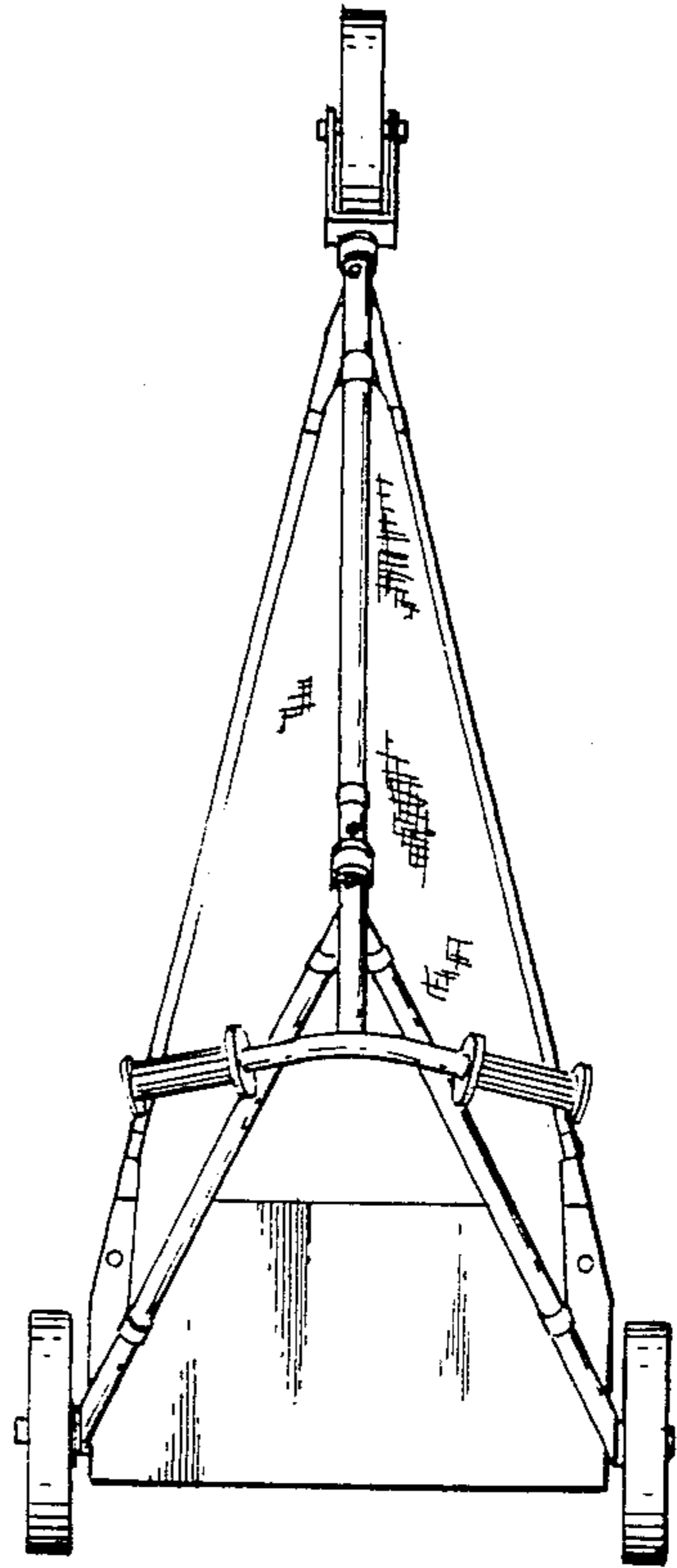

FIG. 5

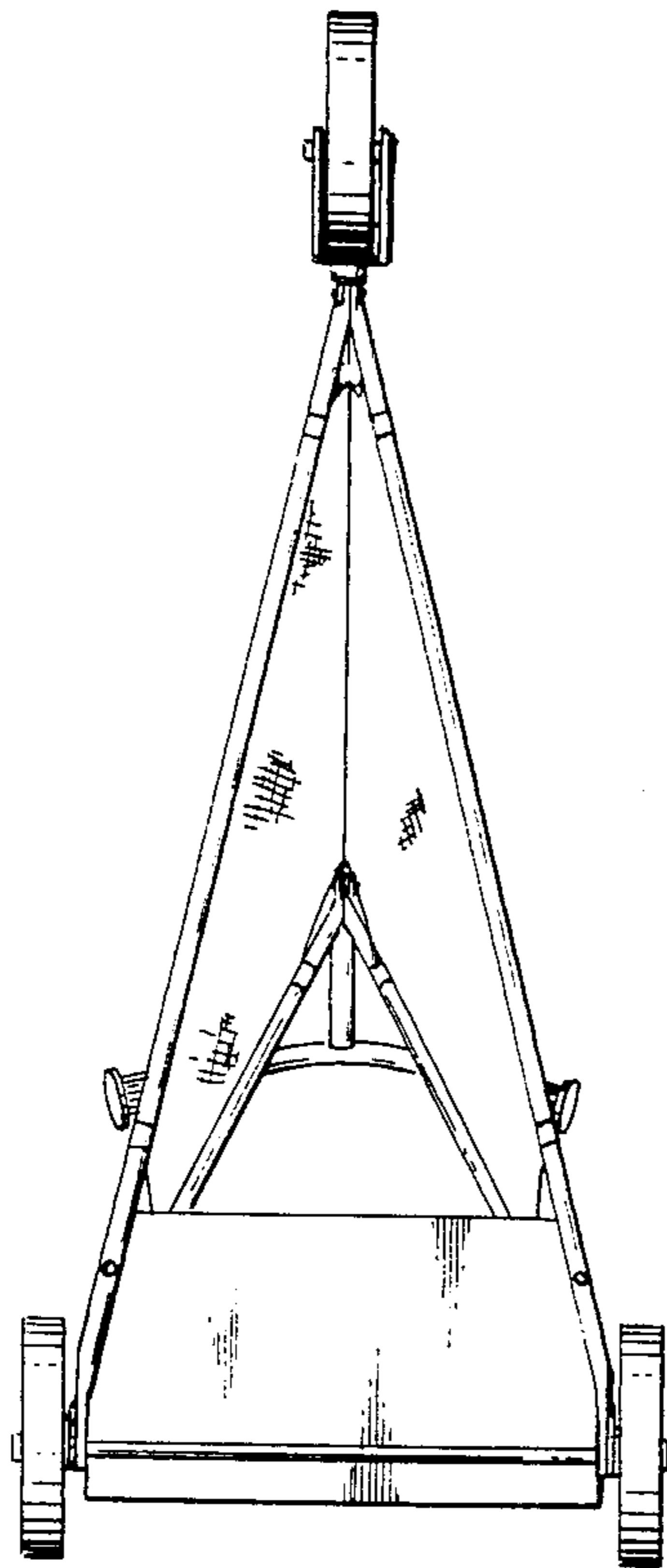

FIG. 6

