

[54] AIRCRAFT

[75] Inventor: Alessandro Mazzoni, Genova, Italy

[73] Assignee: Rinaldo Piaggio S.p.A., Milan, Italy

[\*\*] Term: 14 Years

[21] Appl. No.: 387,022

[22] Filed: Jun. 10, 1982

[30] Foreign Application Priority Data

Jan. 25, 1982 [IT] Italy ..... 20637 B/82

[52] U.S. Cl. .... D12/332; D12/337; D12/341

[58] Field of Search ..... 244/45 R, 45 A, 55, 244/13, 89; D12/319, 320, 322, 324, 327, 331, 333, 335, 334, 337, 349

[56] References Cited

PUBLICATIONS

Interavia, vol. 35 1980 Jul.-Dec. p. 720 in upper right side, EMB-120, Brasilias.

Interavia, vol. 35 1980 Jul.-Dec. p. 721 in upper right side, Aerospatiale.

Interavia, vol. 35 1980 Jul.-Dec. p. 850. I.A.M Rinaldo Piaggio Ad.

Interavia, vol. 35 1980 Jan.-Jun. p. 123, in center, Pratt & Whitney PT7A Turboprop.

Interavia, vol. 35 1980 Jan.-Jun. p. 123, in lower right, Beechcraft's Commuterline.

Aviation Consulting Incorp. Brochure, Oct. 1980.

Primary Examiner—James M. Gandy

Assistant Examiner—Kay H. Chin

Attorney, Agent, or Firm—Robert M. Hessin

[57] CLAIM

The ornamental design for an aircraft, as shown and described.

DESCRIPTION

FIG. 1 is a side elevational view from one side of the aircraft, the opposite side of the aircraft being a mirror image;

FIG. 2 is a top plan view thereof;

FIG. 3 is a front elevational view thereof;

FIG. 4 is a rear elevational view thereof; and

FIG. 5 is a bottom plan view thereof.

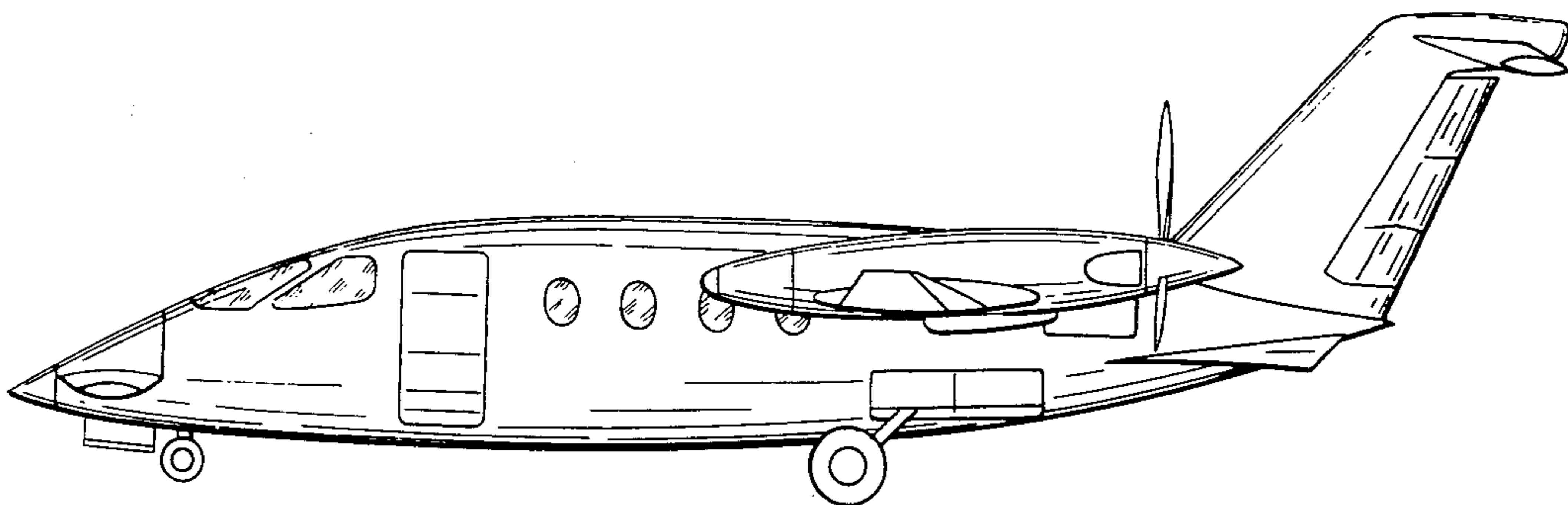

Fig.1

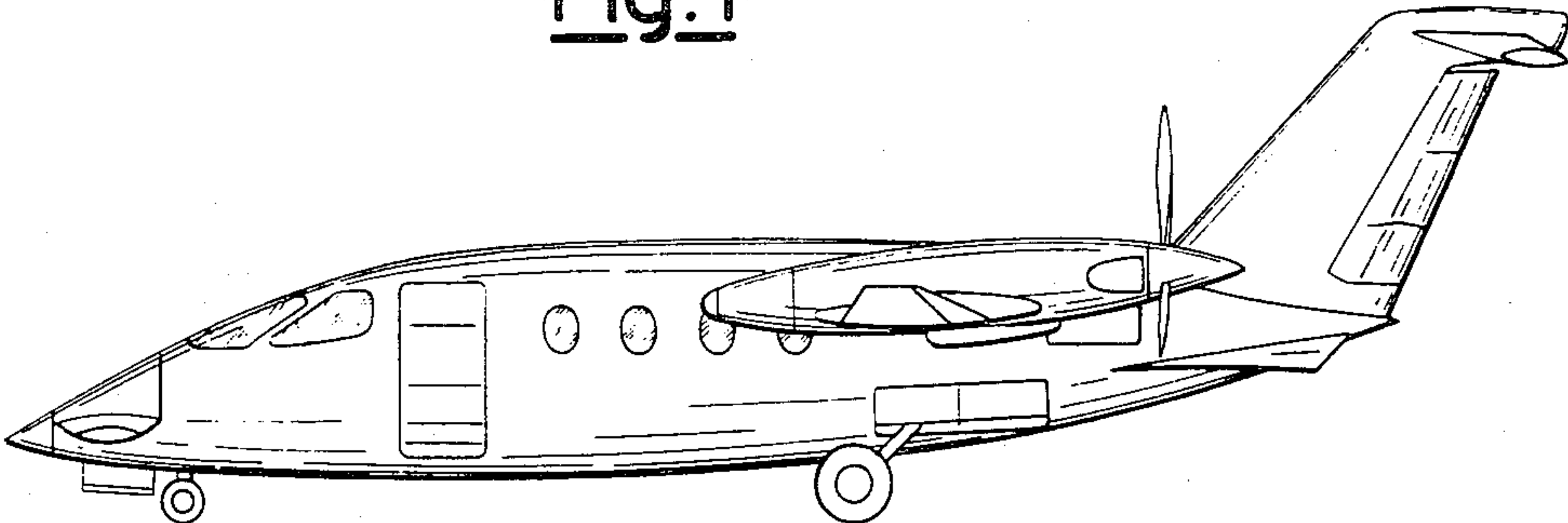

Fig.4

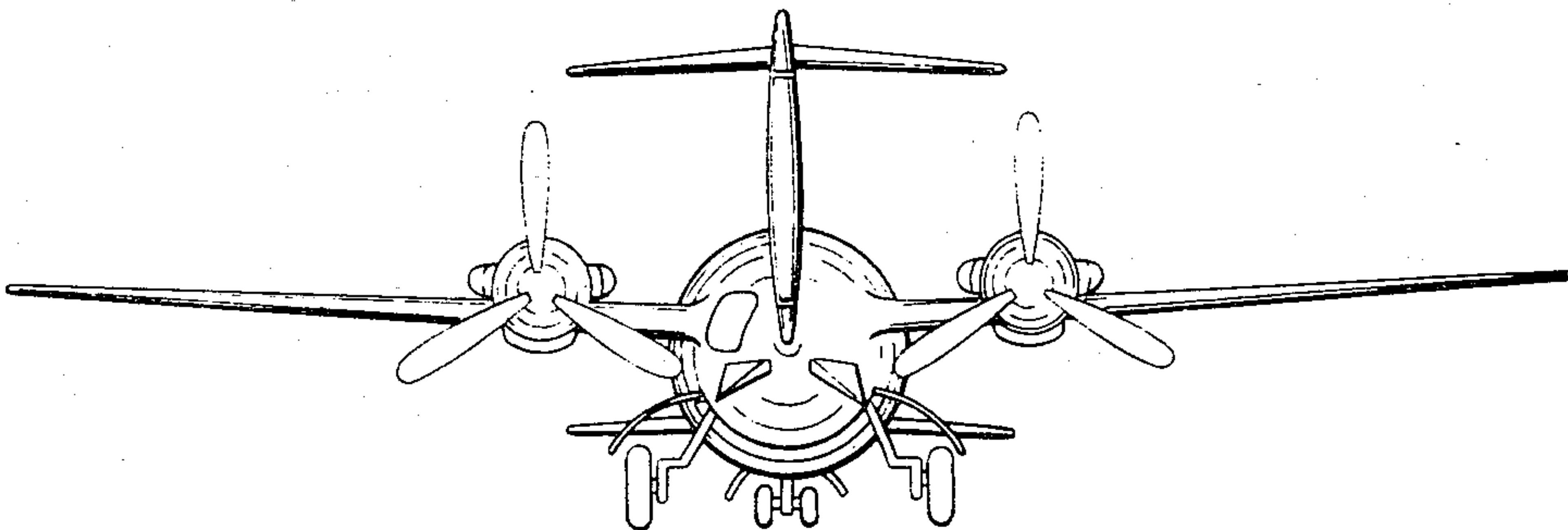

Fig. 2

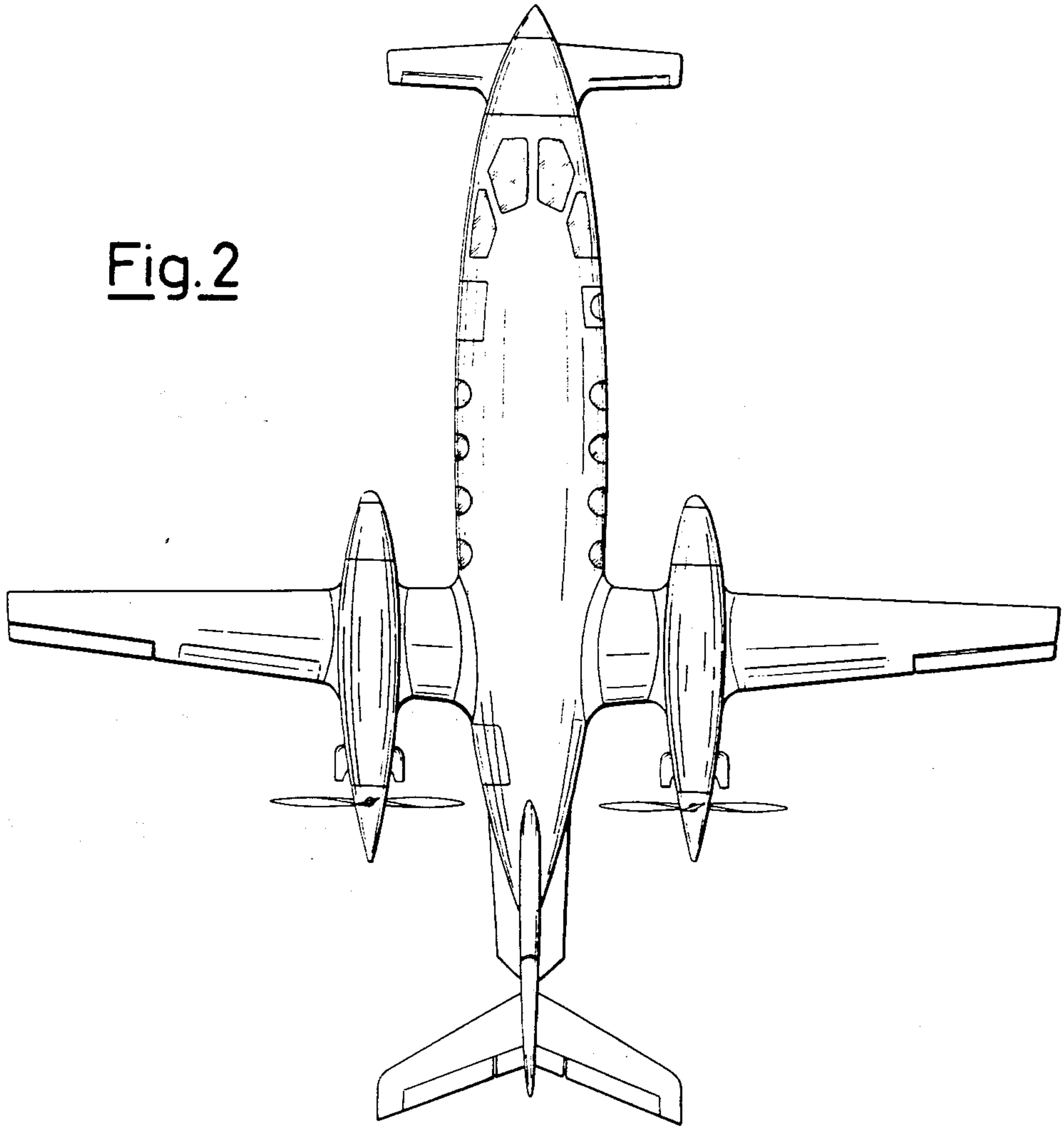

Fig. 3

