

[54] TRICYCLE

[76] Inventors: Robert F. Trudo; Martha J. Trudo, both of 804 Cagle, Harker Heights, Tex. 76543

[**] Term: 14 Years

[21] Appl. No.: 496,965

[22] Filed: May 23, 1983

[52] U.S. Cl. D12/112

[58] Field of Search D12/112, 113; 280/282, 280/259, 202, 204

[56] References Cited

U.S. PATENT DOCUMENTS

D. 150,818	8/1948	Totz	D12/113
D. 159,103	6/1950	Smith	D12/113
D. 162,540	3/1951	Hsu	D12/112
D. 203,757	2/1966	Brettner	D12/113
1,105,731	8/1914	Wells	280/204
1,562,367	11/1925	Sanders	280/202
1,608,439	11/1926	Sheler	280/202
2,158,618	5/1939	Dobrowolski	280/202

Primary Examiner—James M. Gandy
Attorney, Agent, or Firm—W. Kirk McCord

[57] CLAIM

The ornamental design for a tricycle, as shown and described.

DESCRIPTION

FIG. 1 is a perspective view of a first embodiment of our new tricycle design with a seat carrier attached thereto;

FIG. 2 is a top plan view thereof;

FIG. 3 is a left side elevation view thereof;

FIG. 4 is a bottom plan view thereof;

FIG. 5 is a front elevation view thereof;

FIG. 6 is a rear elevation view thereof;

FIG. 7 is a perspective view of a second embodiment of our new tricycle design with a truck bed attached thereto; and

FIG. 8 is a rear elevation view of the second embodiment shown in FIG. 7.

The respective sides of the two embodiments opposite to those shown in FIGS. 1 and 7 are respective mirror images thereof.

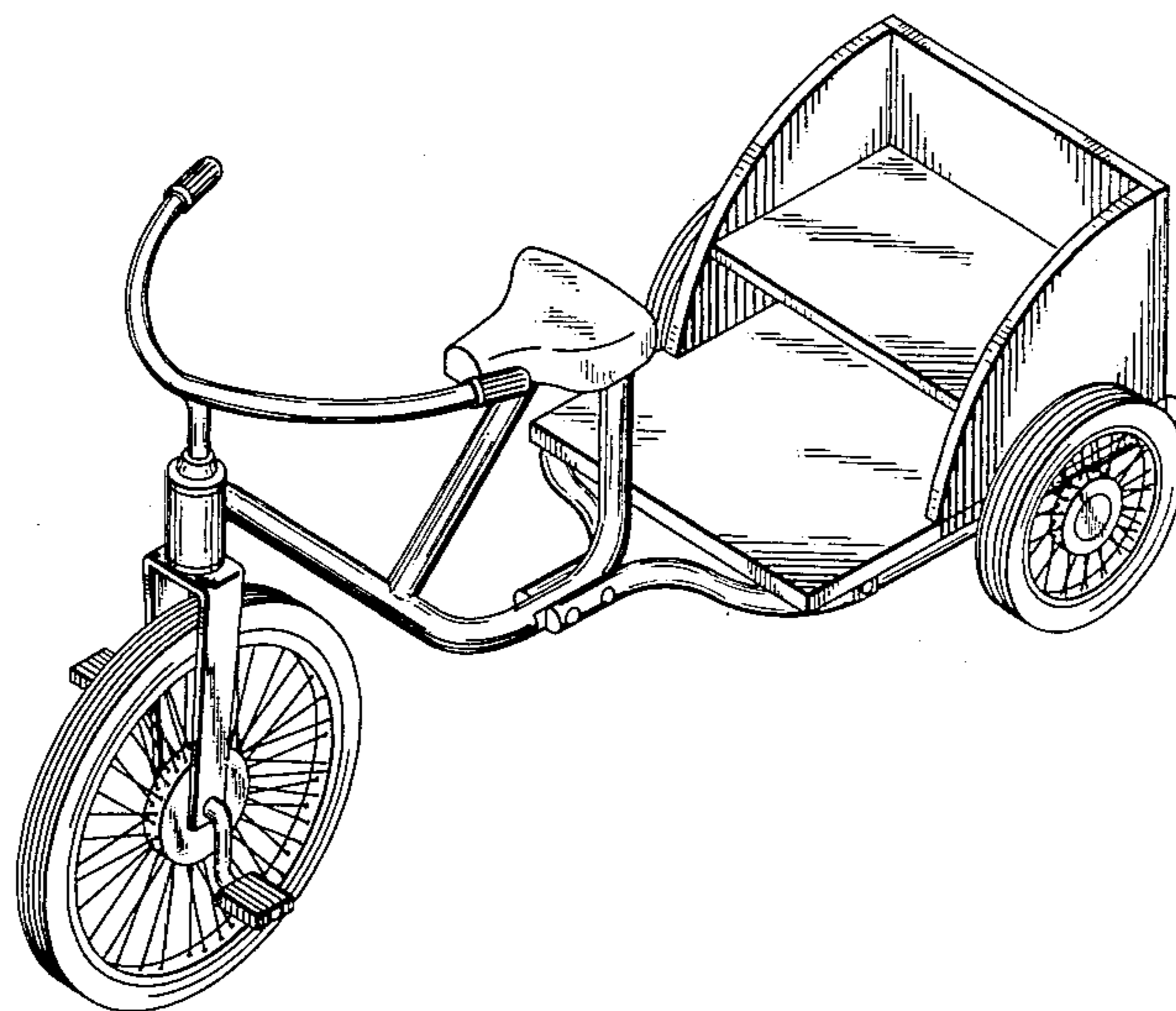

FIG. 1

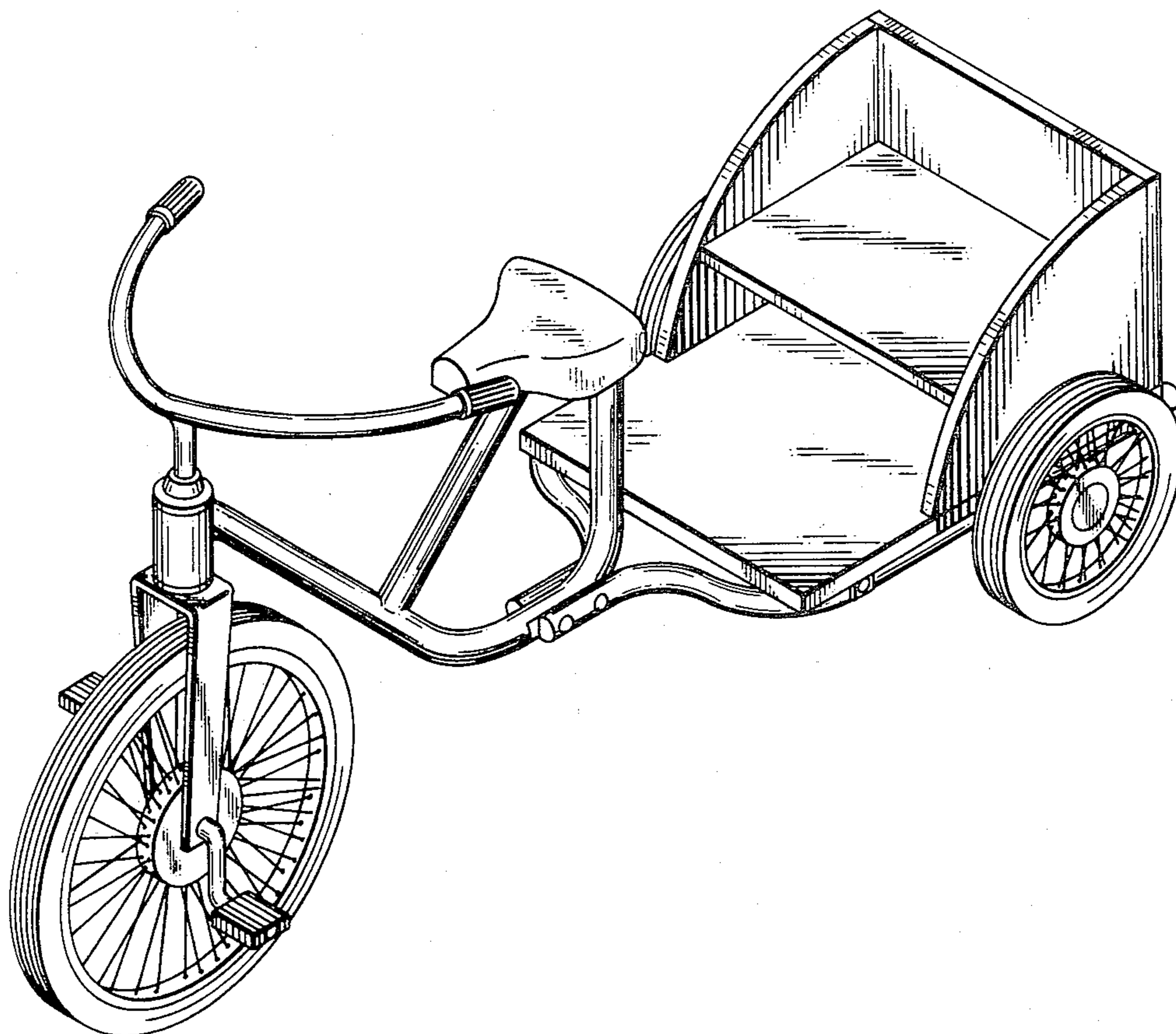

FIG. 2

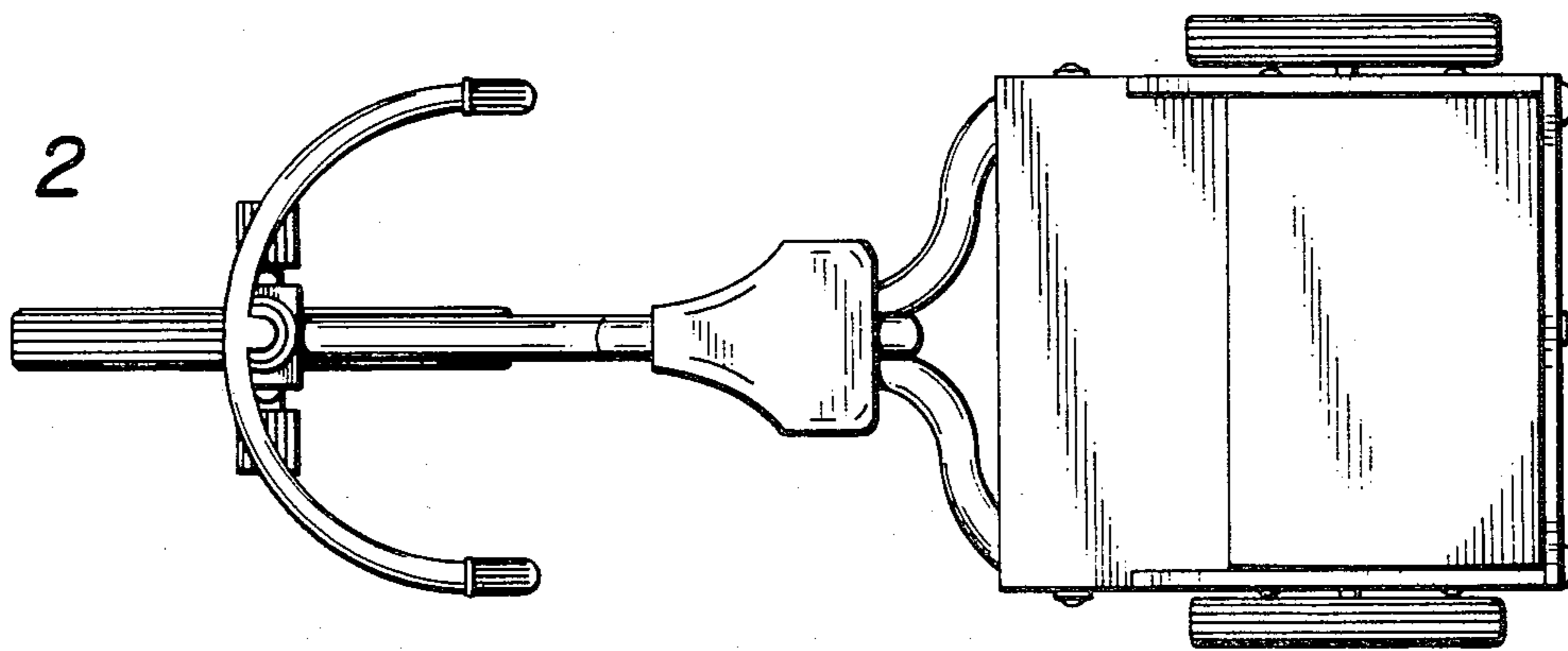
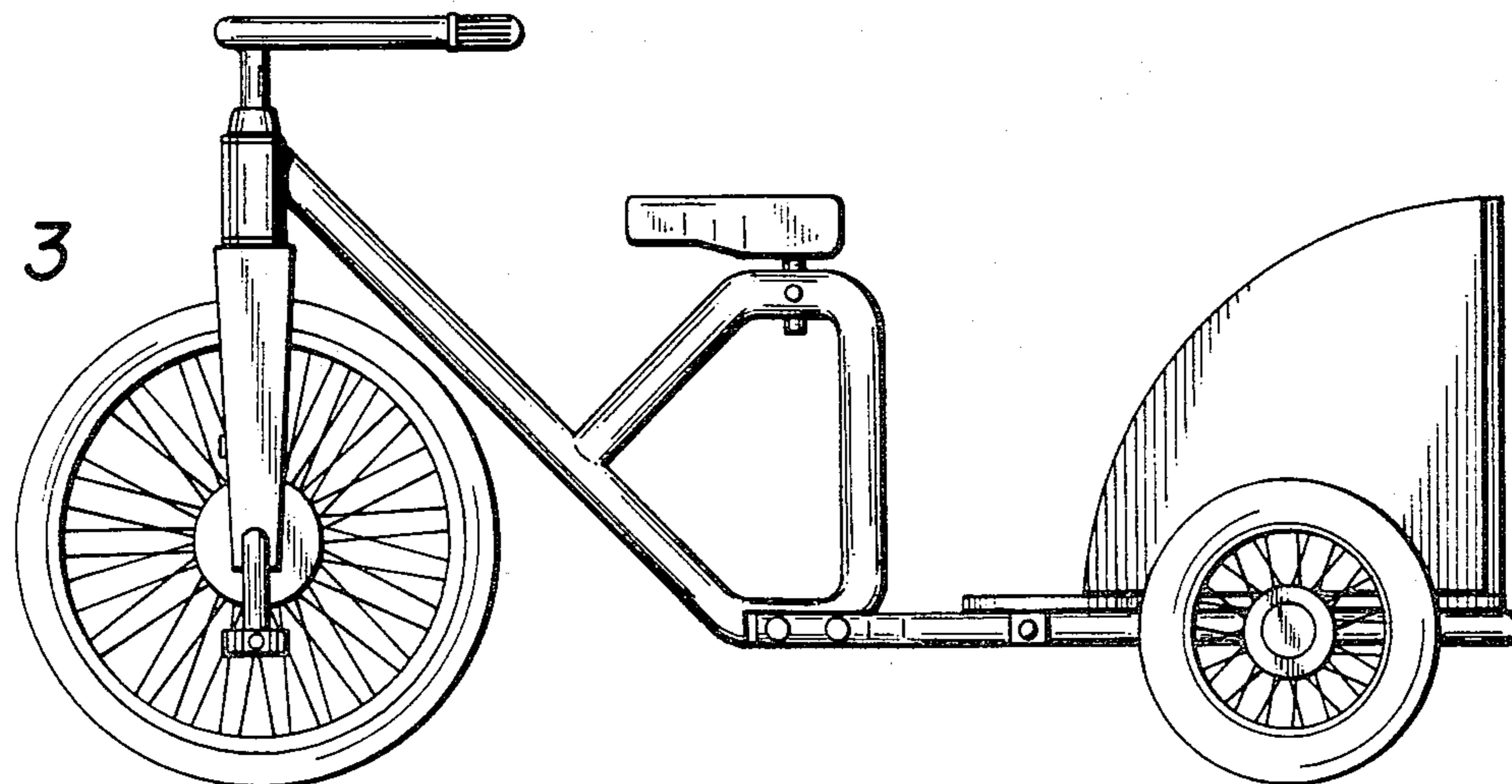

FIG. 3



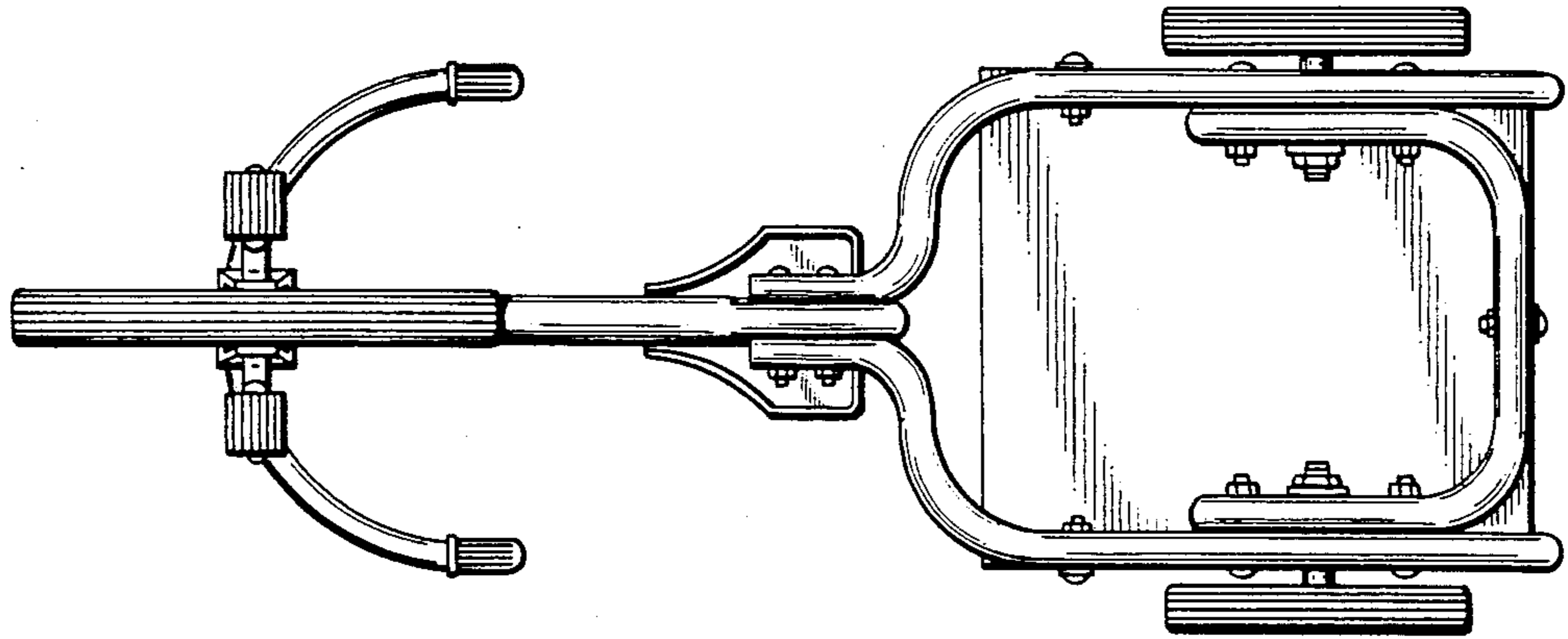

FIG. 4

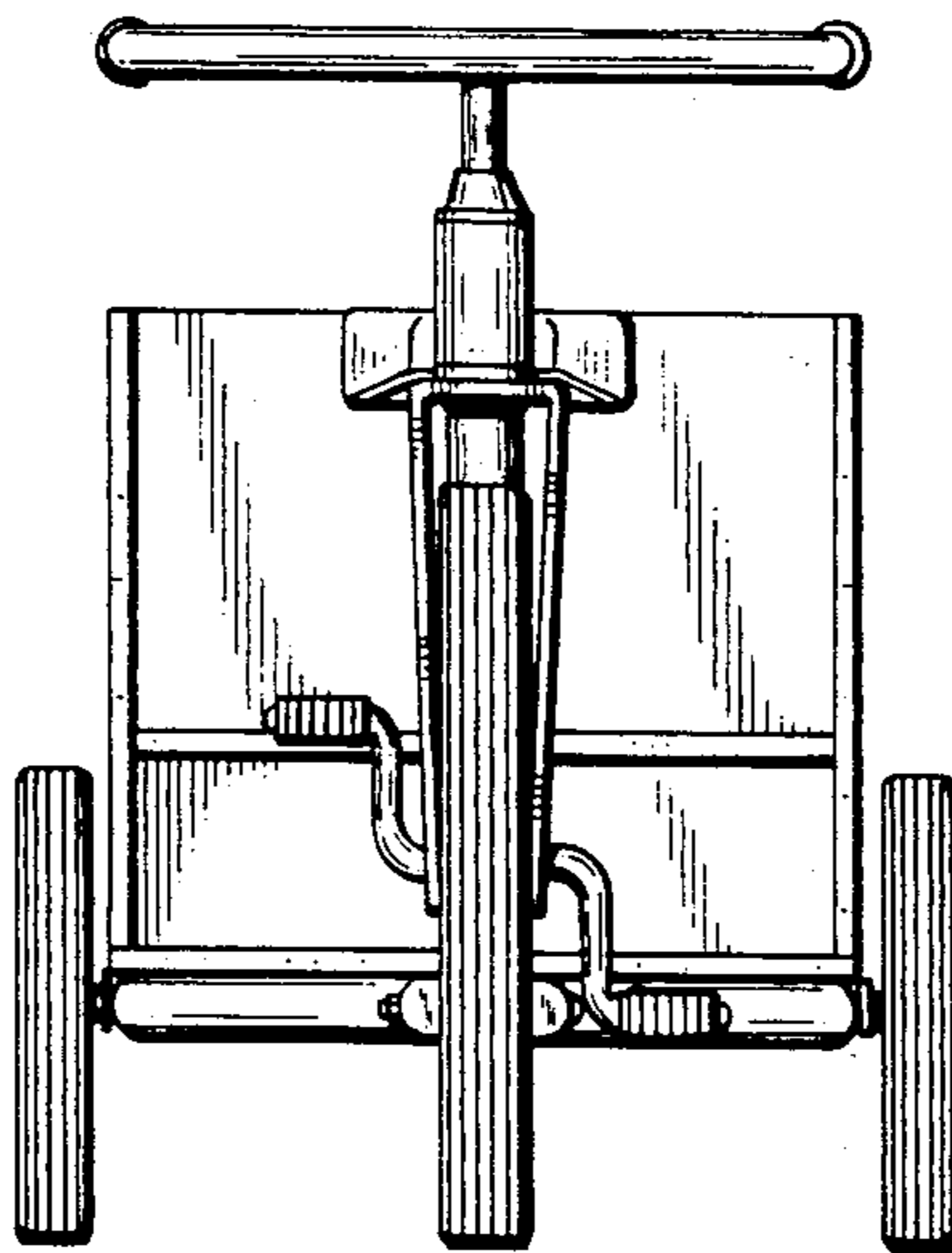

FIG. 5

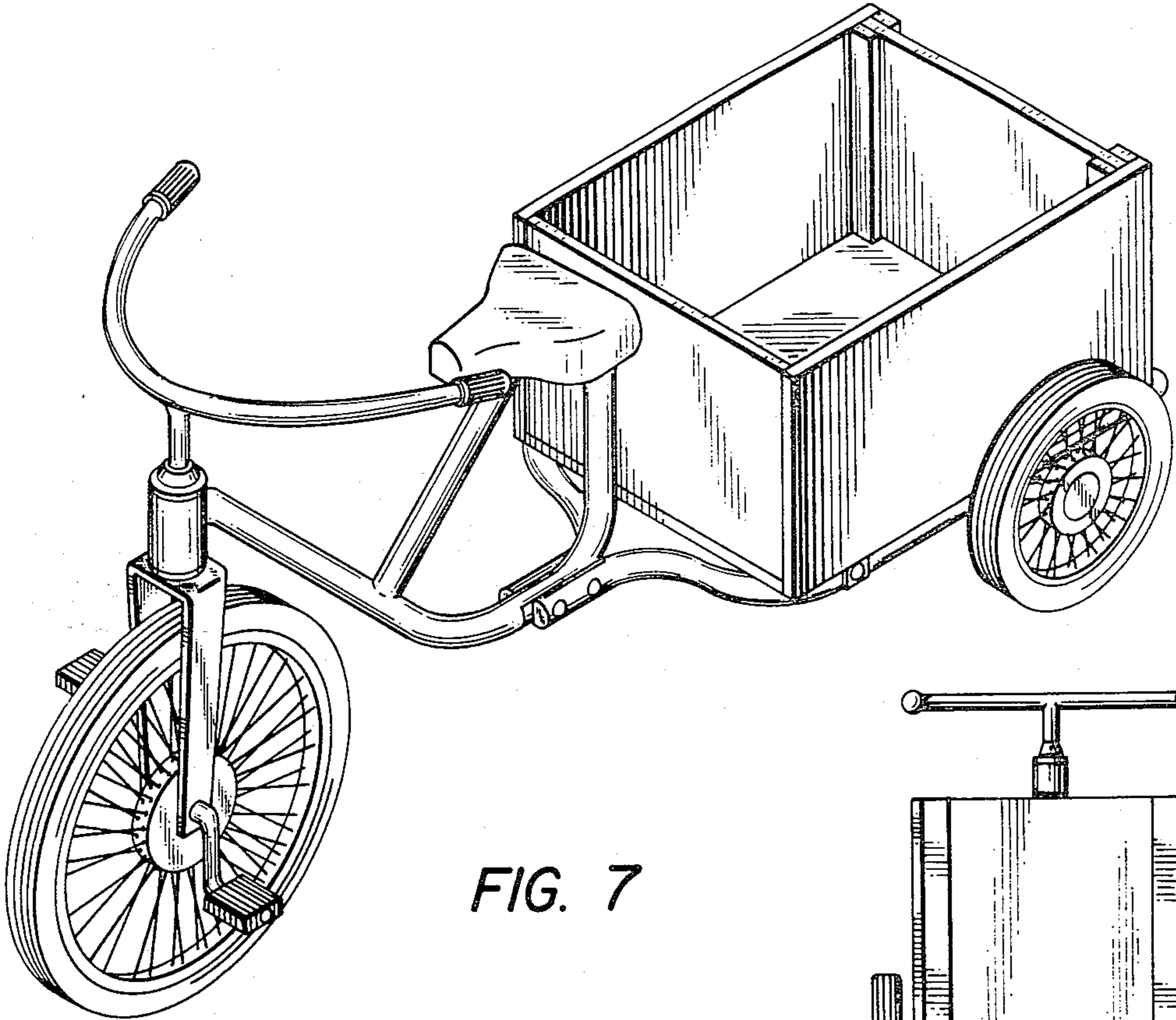

FIG. 7

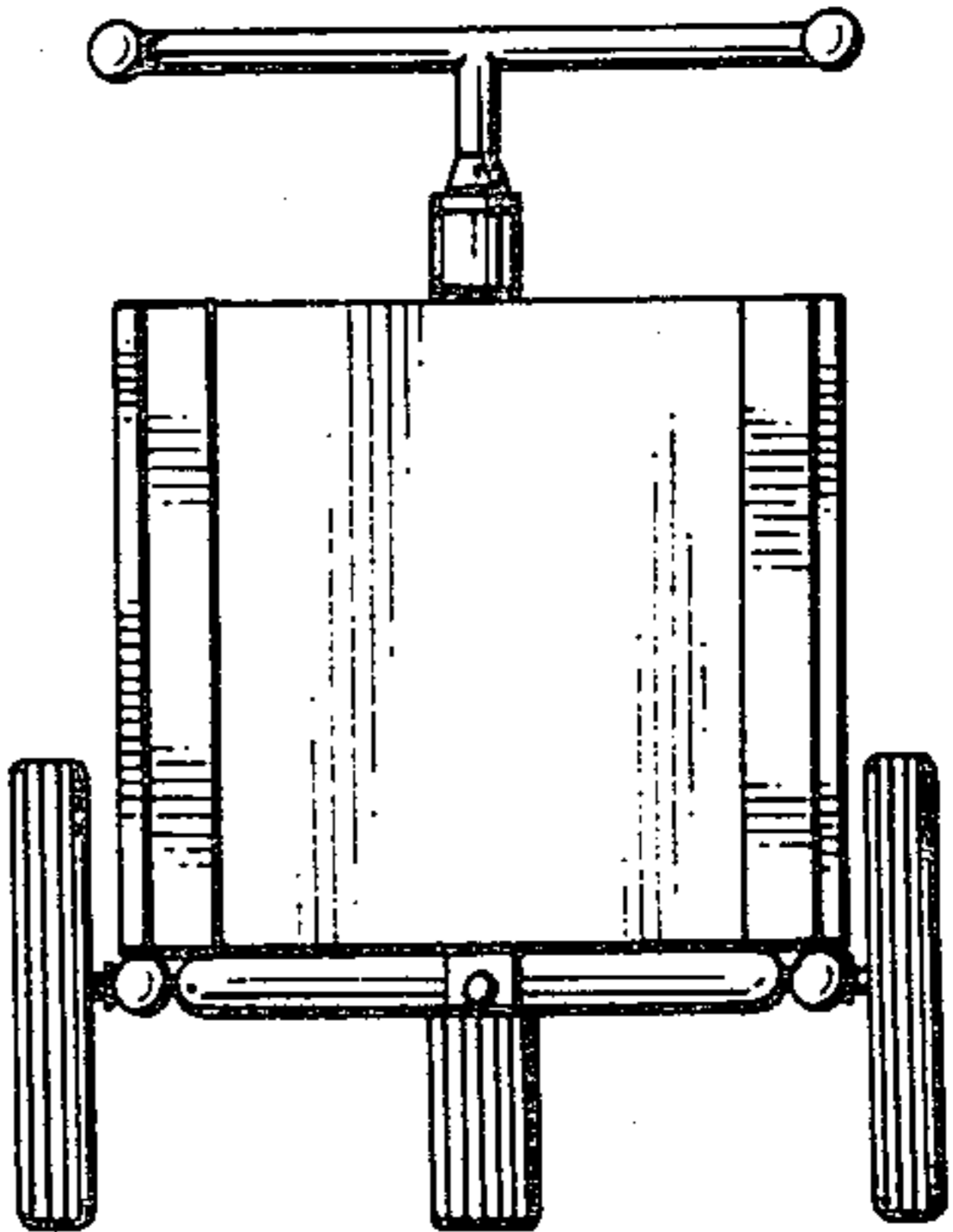

FIG. 8

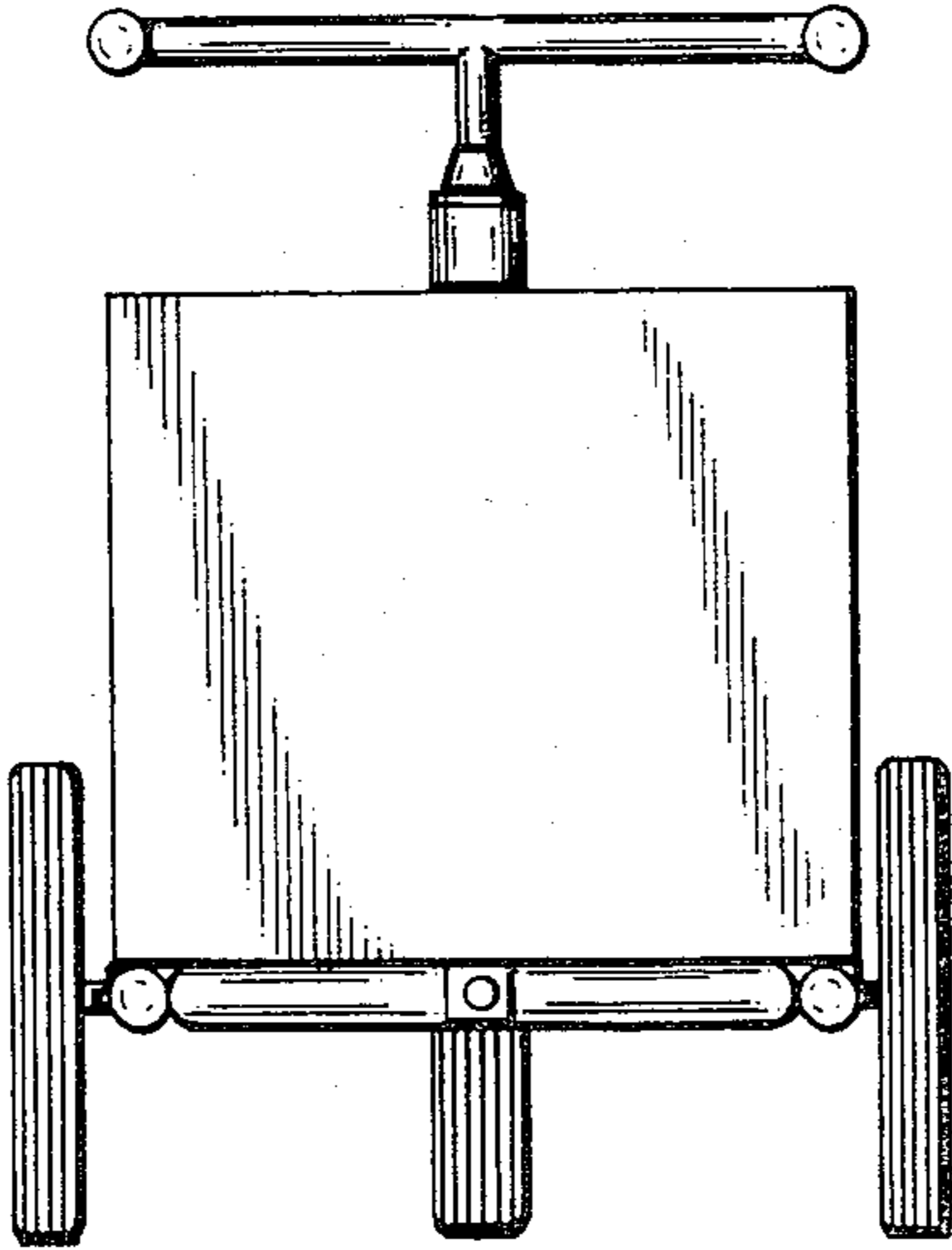

FIG. 6