

[54] **MOTORCYCLE LIGHT INDICATOR**

3,042,797 7/1962 Rubens ..... 362/311

[76] **Inventor: Michael G. Ofield, 1061 Harding St., Long Beach, Calif. 90805**

*Primary Examiner*—Susan J. Lucas  
*Attorney, Agent, or Firm*—Fulwider, Patton, Rieber, Lee & Utecht

[\*\*] **Term: 14 Years**

[21] **Appl. No.: 510,649**

[57] **CLAIM**

The ornamental design for a motorcycle light indicator, substantially as shown and described.

[22] **Filed: Jul. 5, 1983**

[52] **U.S. Cl. .... D26/28**

[58] **Field of Search .... D26/28-37; 362/61, 72, 82, 84, 80, 83, 235, 267, 297, 310, 311, 362**

**DESCRIPTION**

FIG. 1 is a perspective view of a motorcycle light indicator, showing my new design, a portion of the support bracket being omitted as not forming a part of the present design;

FIG. 2 is a right side elevational view thereof;

FIG. 3 is a rear elevational view thereof;

FIG. 4 is a front elevational view thereof;

FIG. 5 is a top plan view thereof;

FIG. 6 is a bottom plan view thereof; and

FIG. 7 is a left side elevational view thereof.

[56] **References Cited**

**U.S. PATENT DOCUMENTS**

1,595,173	8/1926	Stiert .....	362/297 X
1,687,144	10/1928	Ringers .....	362/311
1,696,904	1/1929	Culver .....	362/311
1,903,462	4/1933	Knox .....	362/61 X

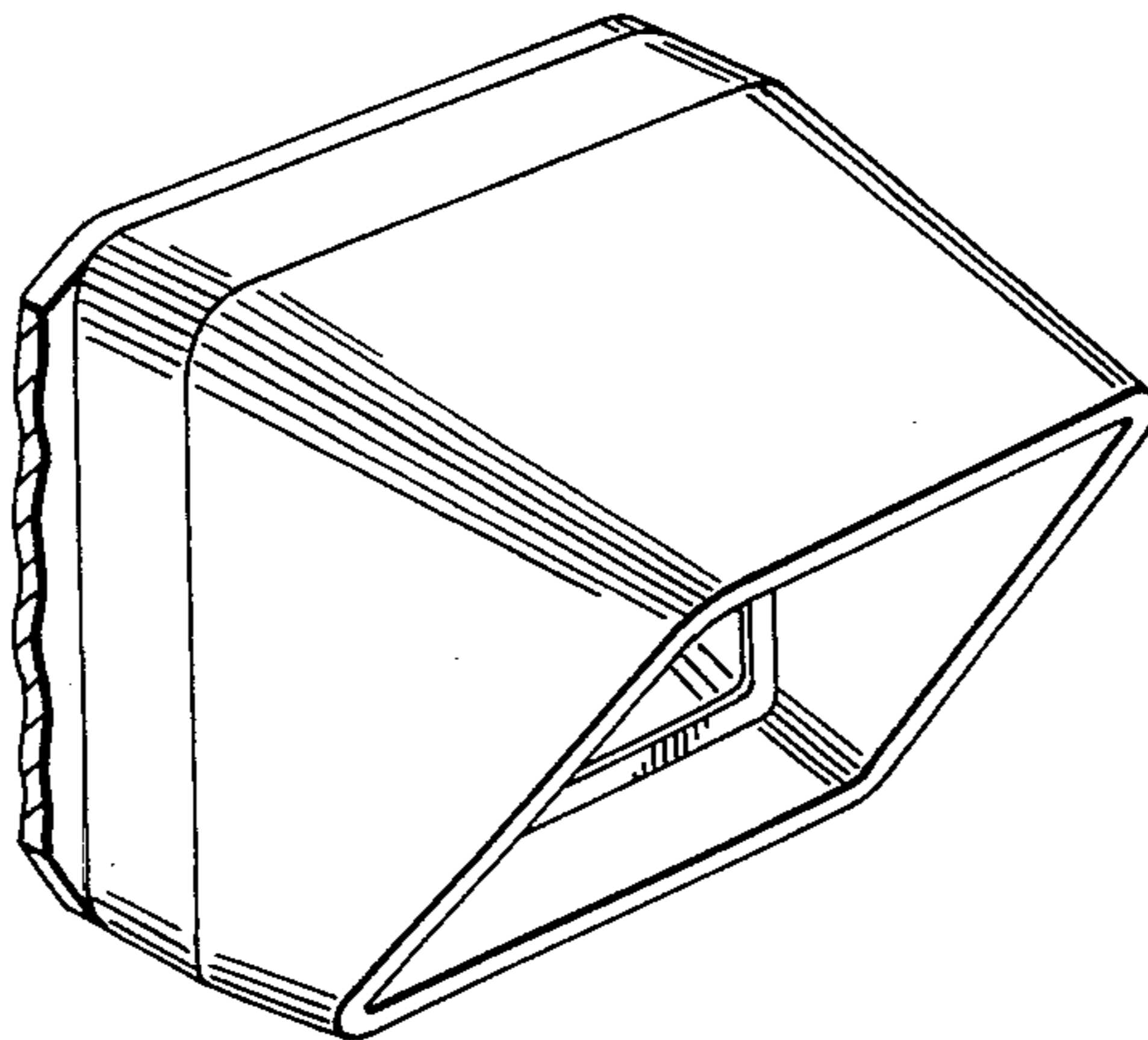

FIG. 1

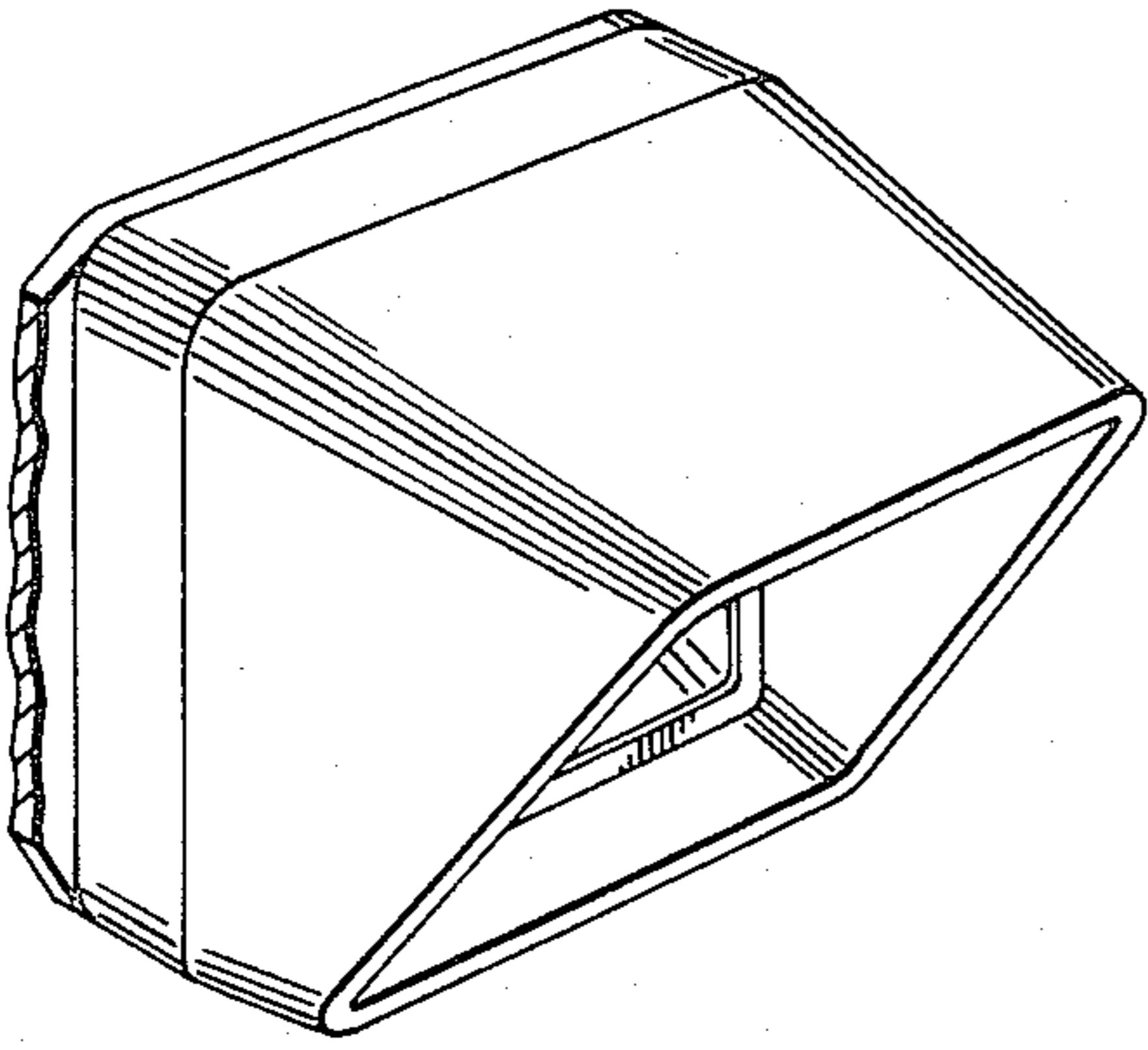

FIG. 2

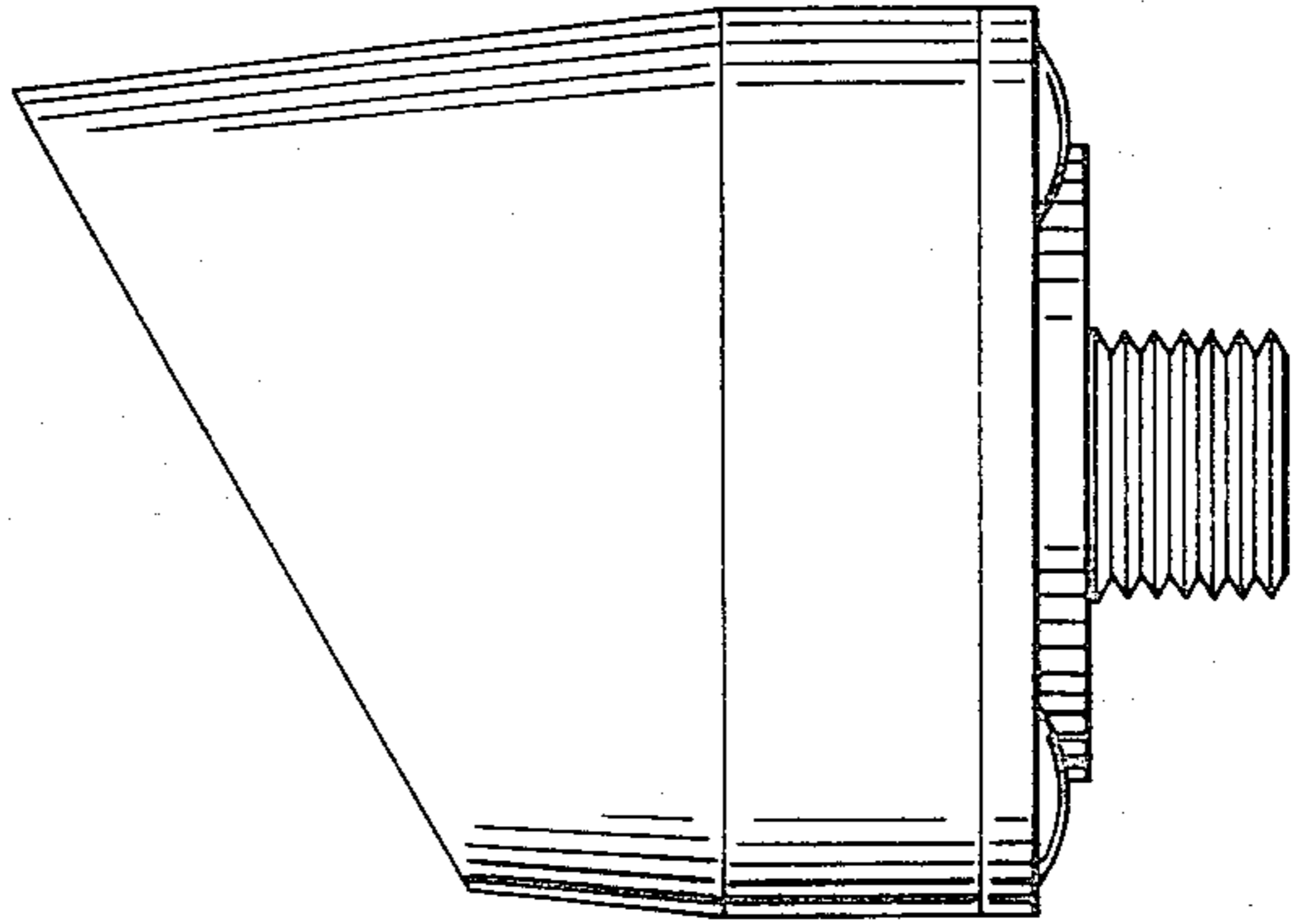

FIG. 3

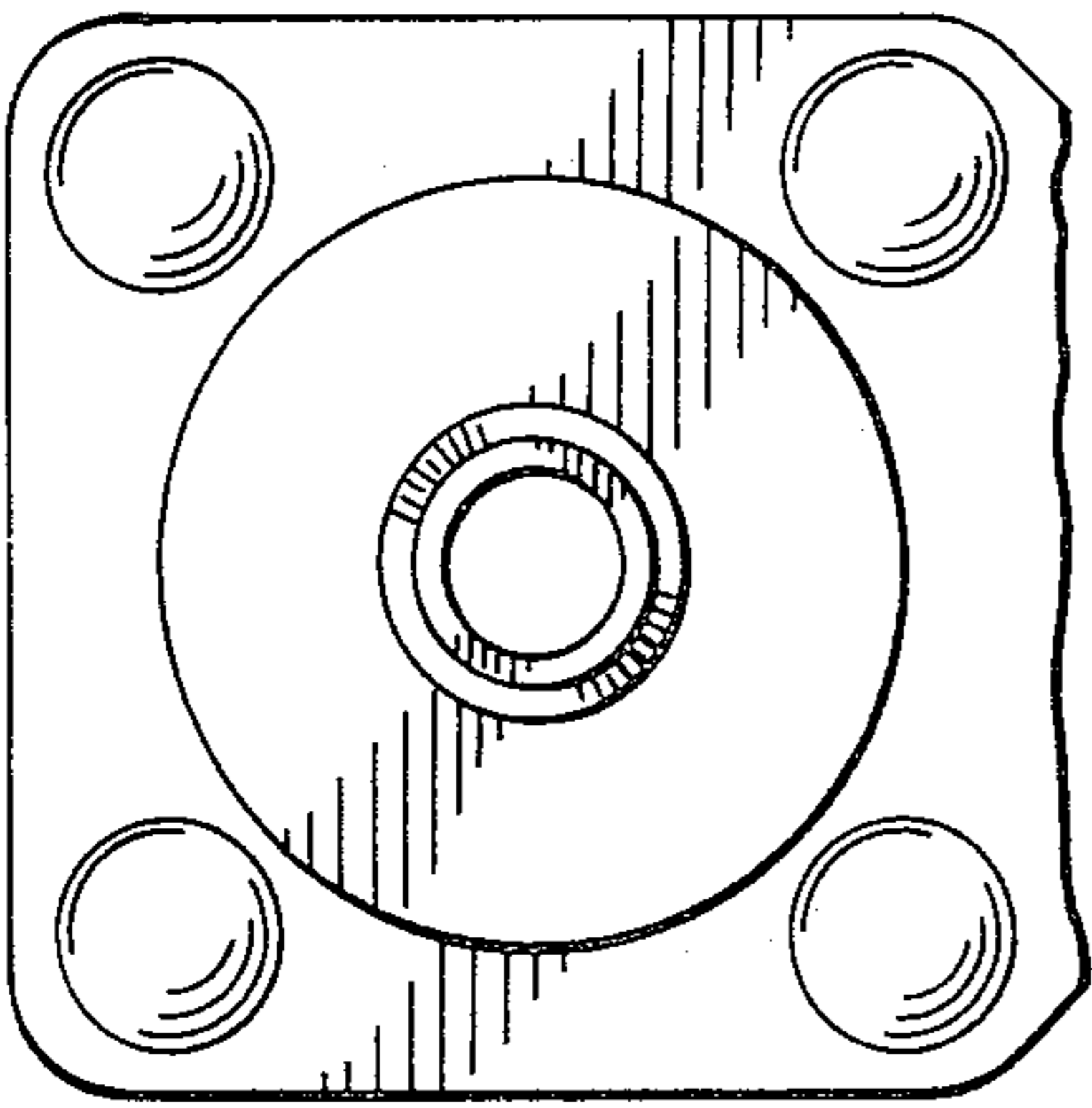

FIG. 4

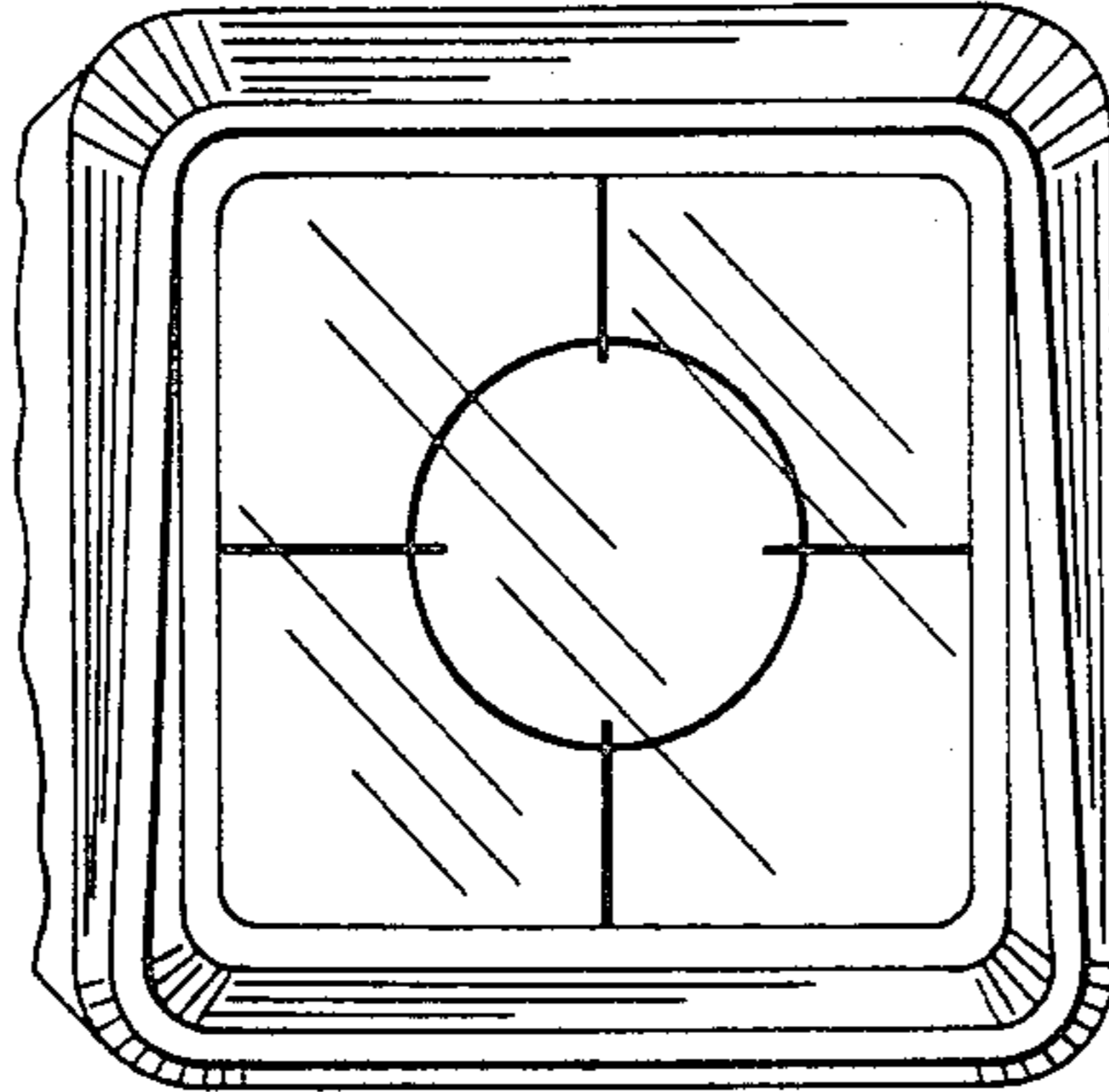

FIG. 5

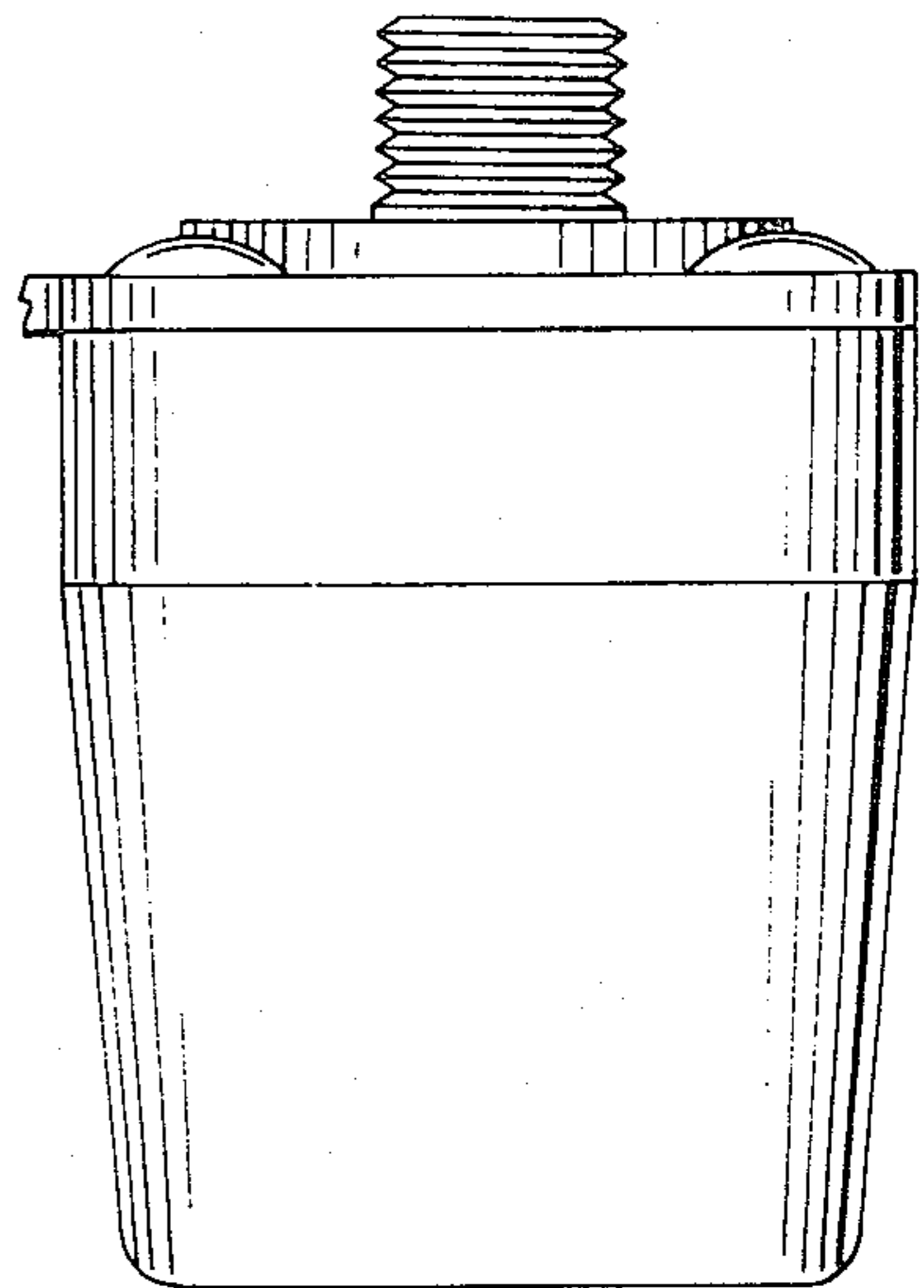

FIG. 6

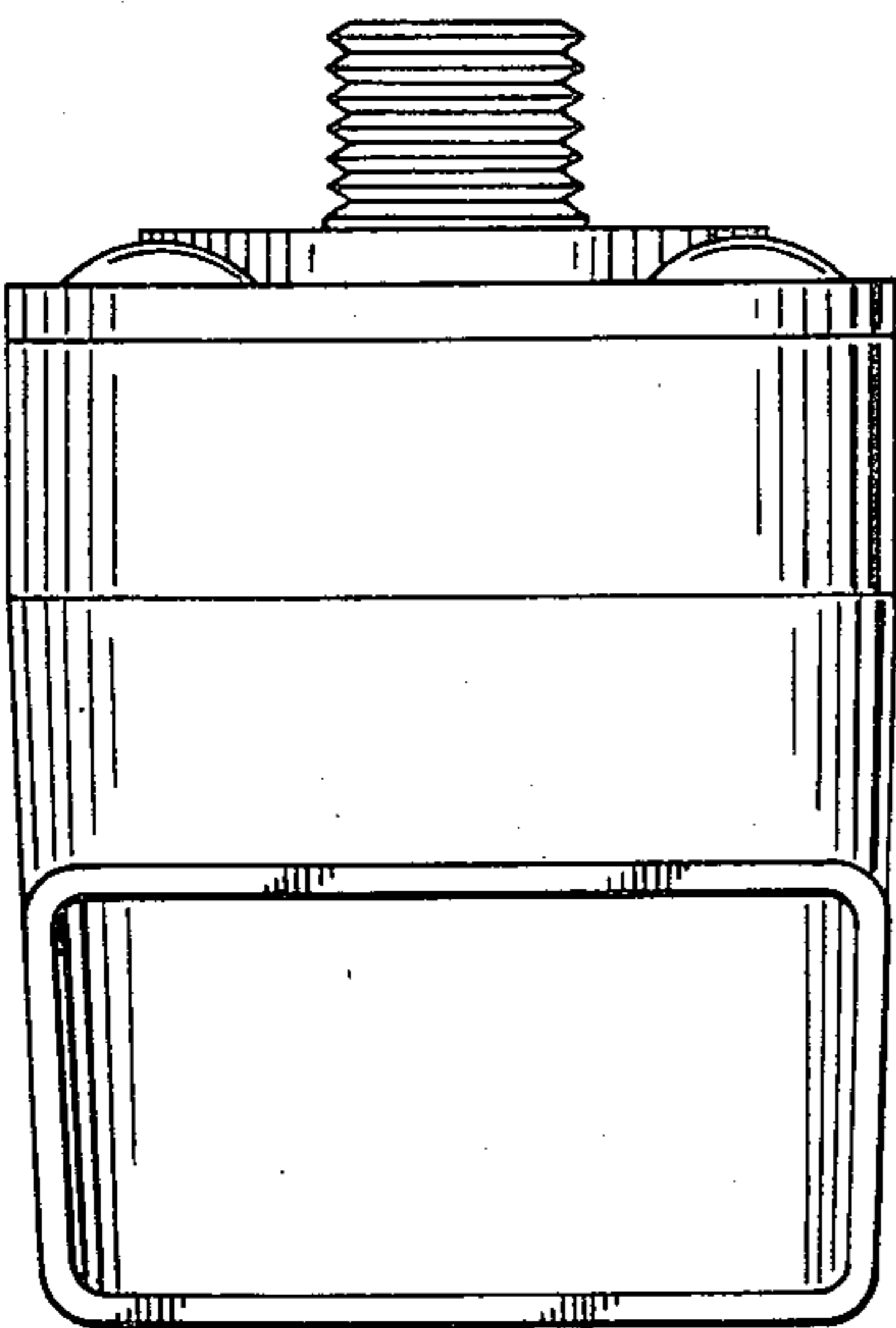

FIG. 7

