

[54] **COMBINED VEHICLE ORNAMENT AND ADVERTISING DEVICE**

[76] Inventor: **Elmar Kaiser**, 6 Route de Meyrin, 1202 Geneva, Switzerland

[\*\*] Term: **14 Years**

[21] Appl. No.: **365,299**

[22] Filed: **Jun. 23, 1982**

[52] U.S. Cl. .... **D12/197**

[58] Field of Search ..... **D12/197; D20/10; D11/131, 157, 164, 141; D21/93; 40/591, 592, 440, 413; 46/47**

[56] **References Cited**

**U.S. PATENT DOCUMENTS**

171,986	1/1876	Burdett	46/47
D. 256,483	8/1980	Kupperman et al.	D21/93
1,435,106	11/1922	Comiskey	D12/197 X
1,588,127	6/1926	Miller	40/413
1,945,789	2/1934	Revis	40/440 X
3,757,730	9/1973	Douglas	40/440 X
3,758,190	9/1973	Douglas	40/440 X

**FOREIGN PATENT DOCUMENTS**

160405	3/1921	United Kingdom	40/413
--------	--------	----------------	--------

**OTHER PUBLICATIONS**

- 1978 Pontiac Catalog, Hood Ornaments on front.
- 1978 Oldsmobile Catalog, Hood Ornament on front.
- 1979 Buick Catalog, Hood Ornament on p. 3.

*Primary Examiner*—Catherine E. Kemper  
*Attorney, Agent, or Firm*—Fleit, Jacobson, Cohn & Price

[57] **CLAIM**

The ornamental design for a combined vehicle ornament and advertising device, as shown.

**DESCRIPTION**

FIG. 1 is a front elevational view of a combined vehicle ornament and advertising device, showing my new design;  
 FIG. 2 is a side elevational view thereof, shown with the central panel rotated;  
 FIG. 3 is a perspective view thereof;  
 FIG. 4 is a top plan view thereof;  
 FIG. 5 is a front elevational view of a second embodi-

ment of a combined vehicle ornament and advertising device;  
 FIG. 6 is a side elevational view thereof, shown with the central panel rotated;  
 FIG. 7 is a perspective view thereof;  
 FIG. 8 is a top plan view thereof;  
 FIG. 9 is a front elevational view of a third embodiment of a combined vehicle ornament and advertising device;  
 FIG. 10 is a side elevational view thereof, shown with the central panel rotated;  
 FIG. 11 is a perspective view thereof;  
 FIG. 30 is a side elevational view thereof, shown with the central panel rotated;  
 FIG. 31 is a perspective view thereof;  
 FIG. 32 is a top plan view thereof;  
 FIG. 33 is a front elevational view of a ninth embodiment of a combined vehicle ornament and advertising device;  
 FIG. 34 is a side elevational view thereof, shown with the central panel rotated;  
 FIG. 35 is a perspective view thereof;  
 FIG. 36 is a top plan view thereof;  
 FIG. 37 is a front elevational view of a tenth embodiment of a combined vehicle ornament and advertising device;  
 FIG. 38 is a side elevational view thereof, shown with the central panel rotated;  
 FIG. 39 is a perspective view thereof;  
 FIG. 40 is a top plan view thereof;  
 FIG. 41 is a front elevational view of an eleventh embodiment of a combined vehicle ornament and advertising device;  
 FIG. 42 is a side elevational view thereof, shown with the central panel rotated;  
 FIG. 43 is a perspective view thereof;  
 FIG. 44 is a top plan view thereof;  
 FIG. 45 is a front elevational view of a twelfth embodiment of a combined vehicle ornament and advertising device;  
 FIG. 46 is a side elevational view thereof, shown with the central panel rotated;  
 FIG. 47 is a perspective view thereof;  
 FIG. 48 is a top plan view thereof;  
 FIG. 49 is a front elevational view of a thirteenth embodiment of a combined vehicle ornament and advertising device;  
 FIG. 50 is a side elevational view thereof, shown with the central panel rotated;

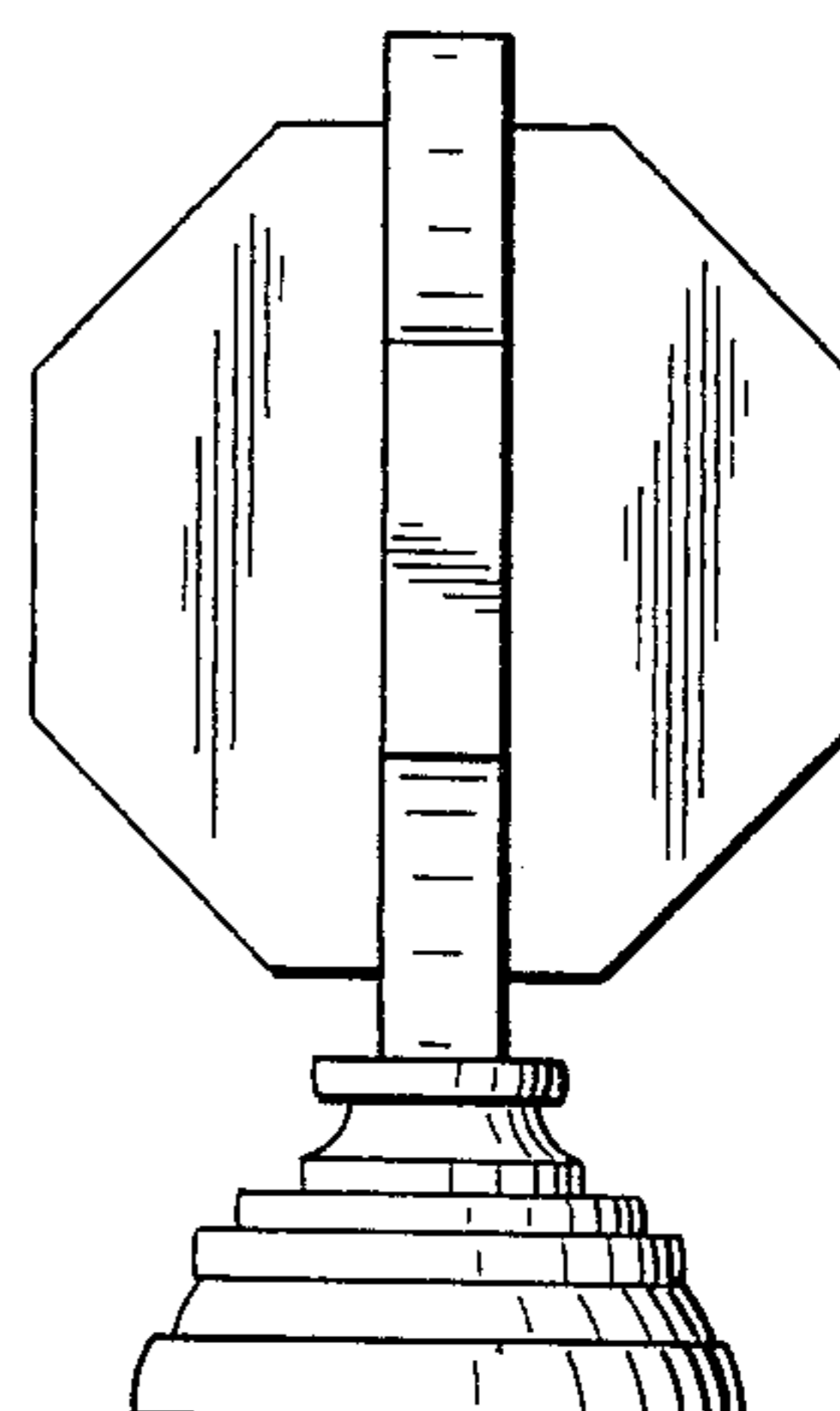
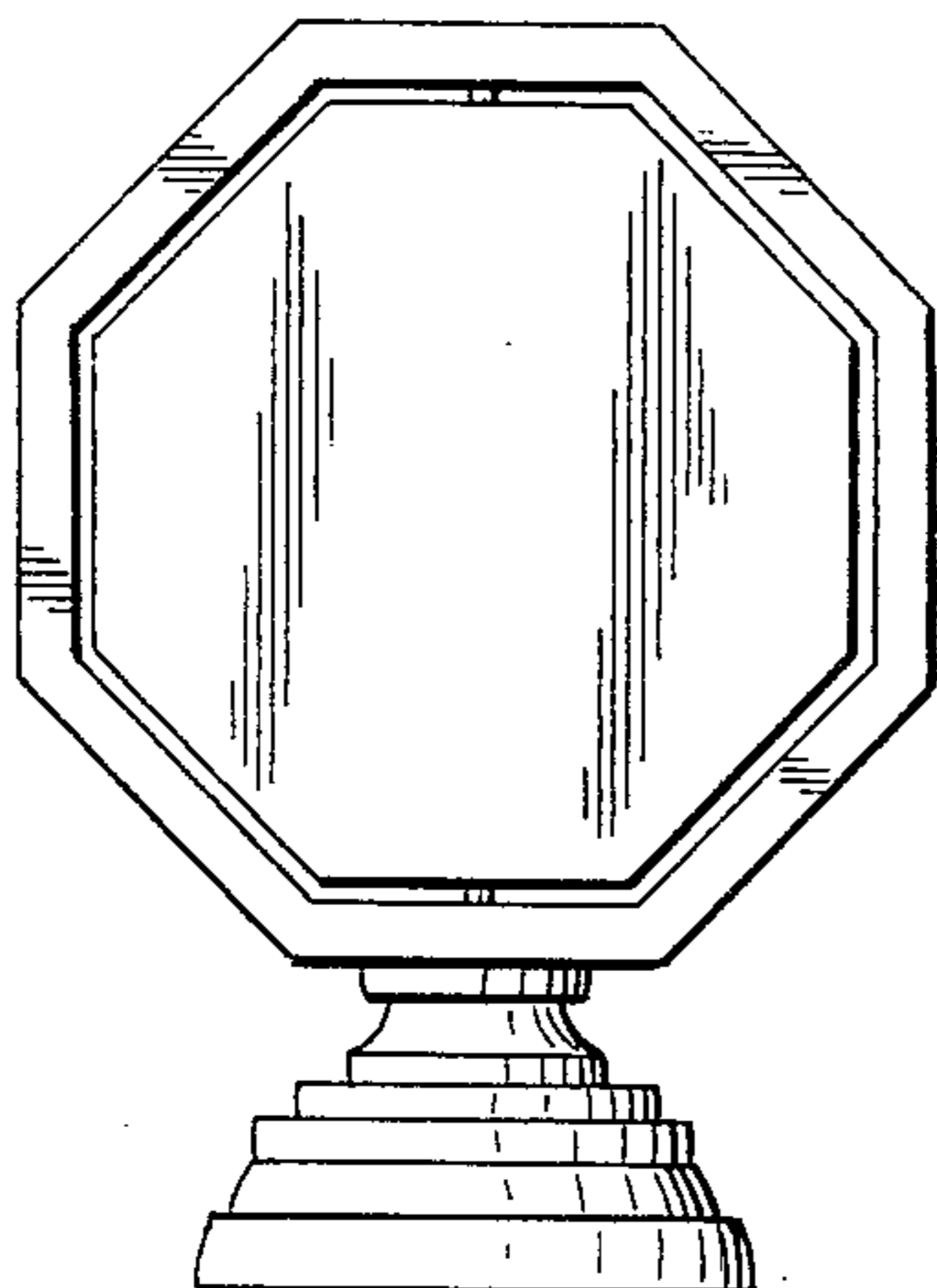

FIG. 1

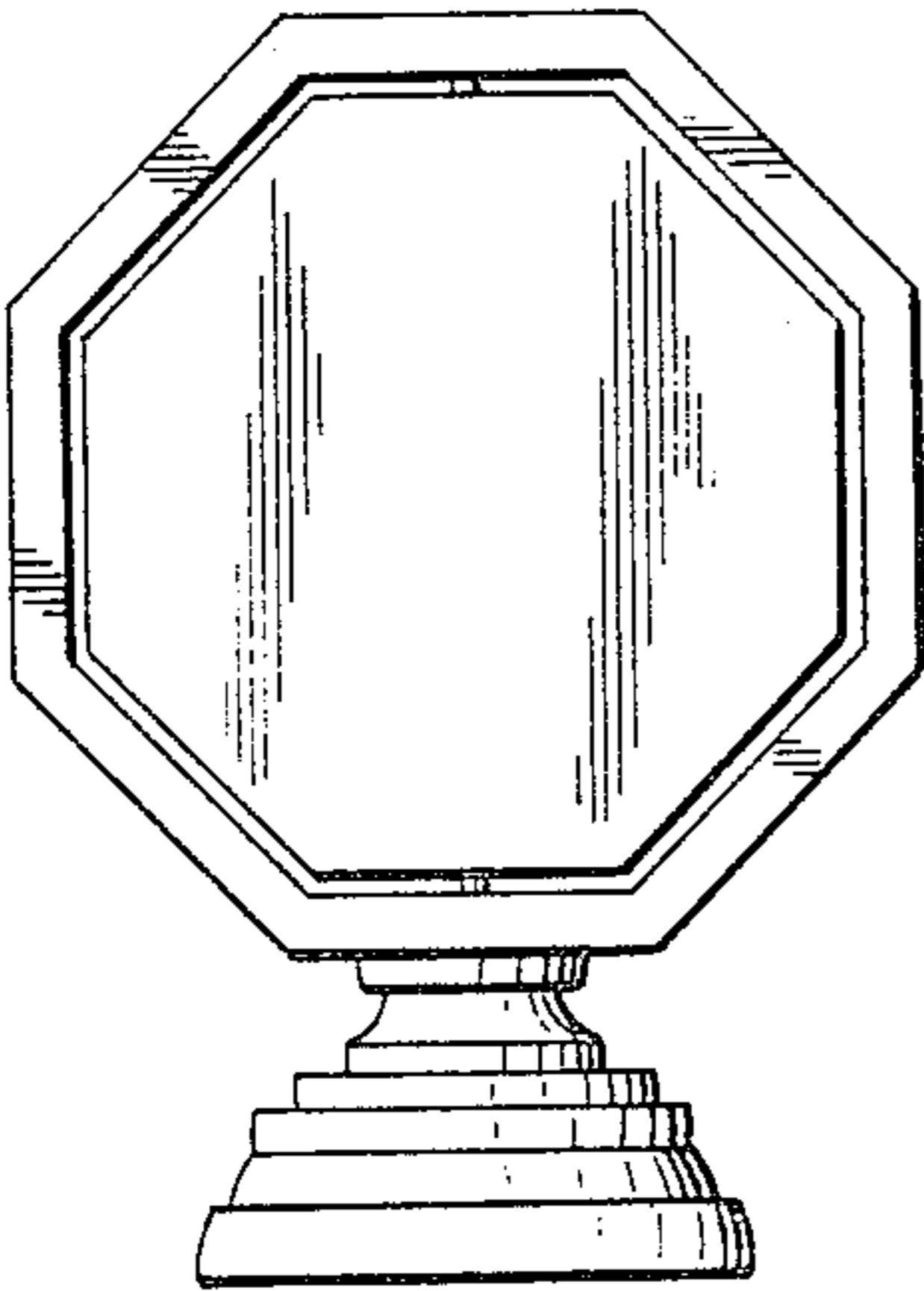

FIG. 2

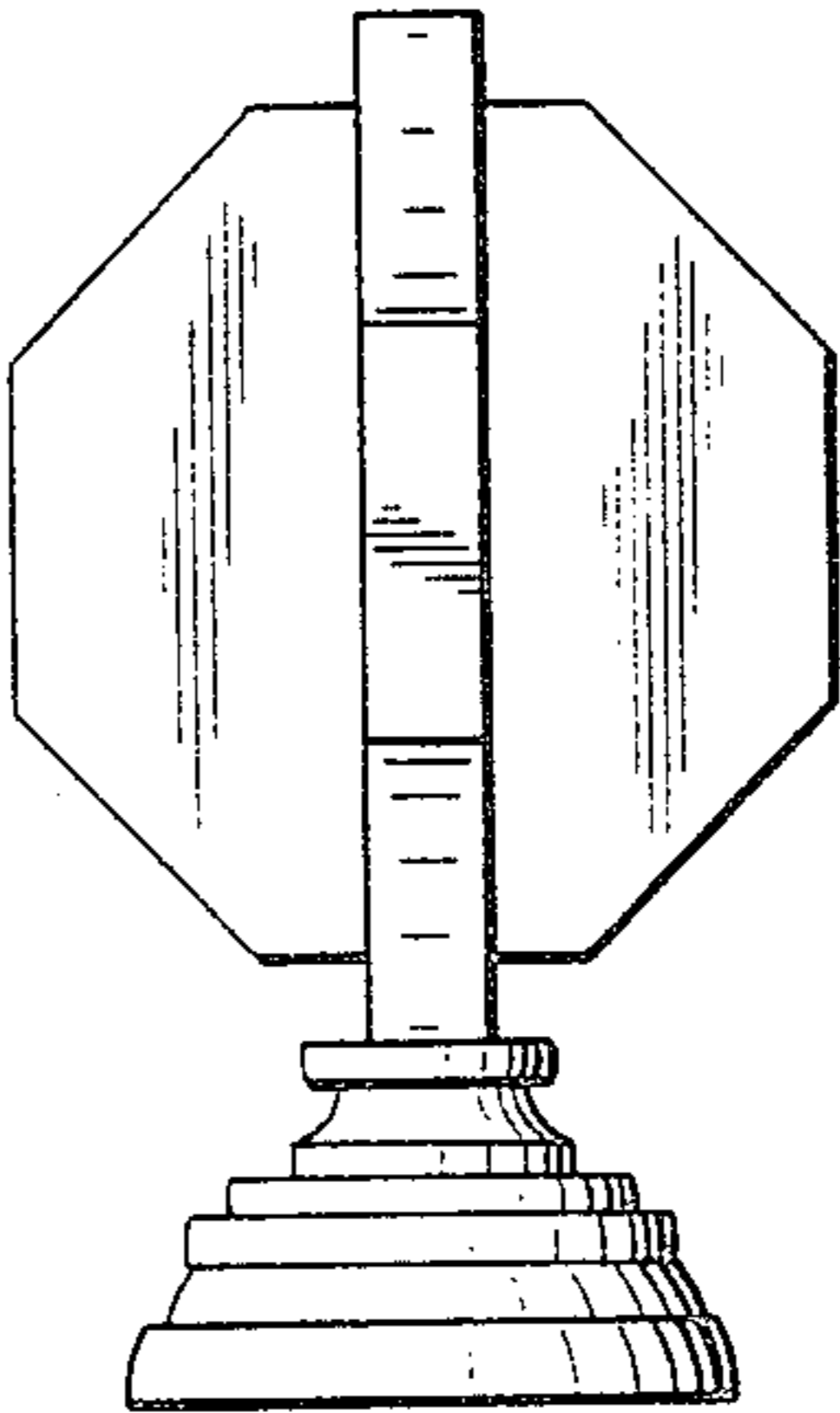

FIG. 3

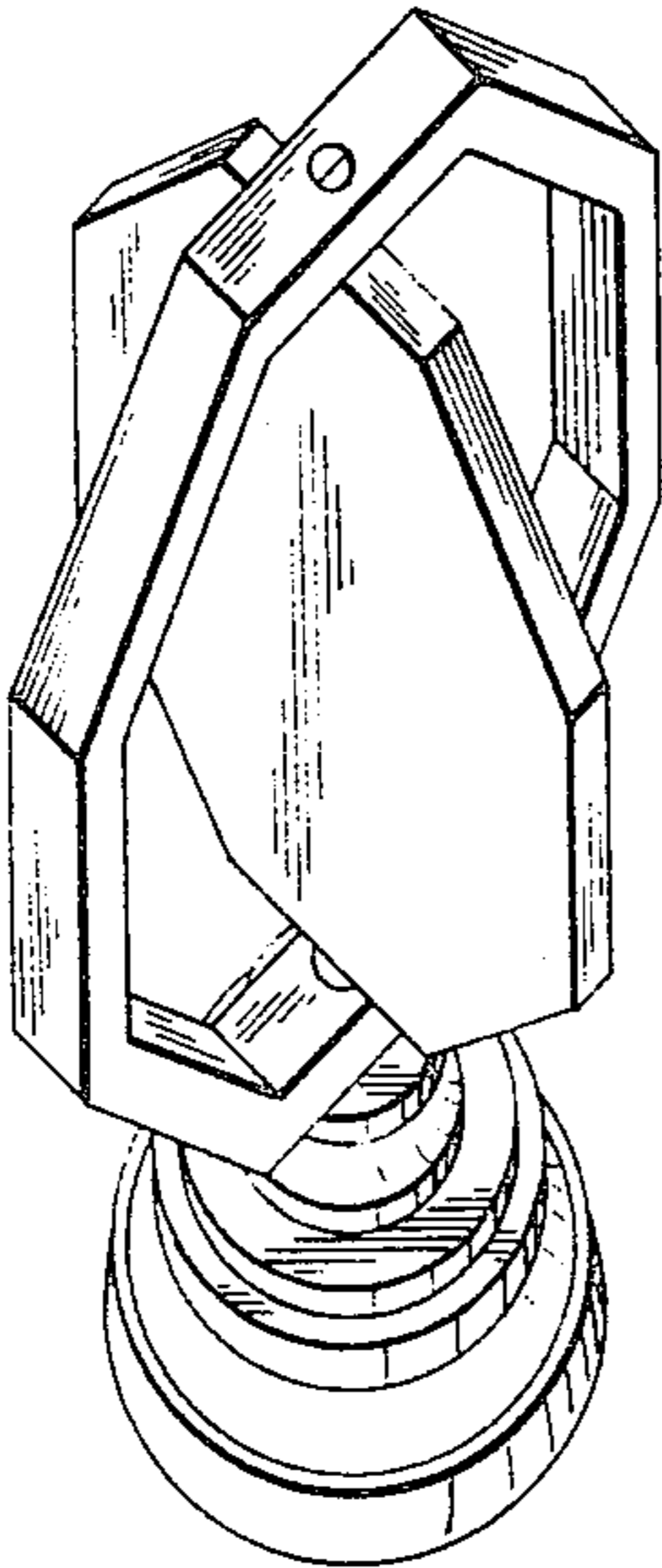

FIG. 4

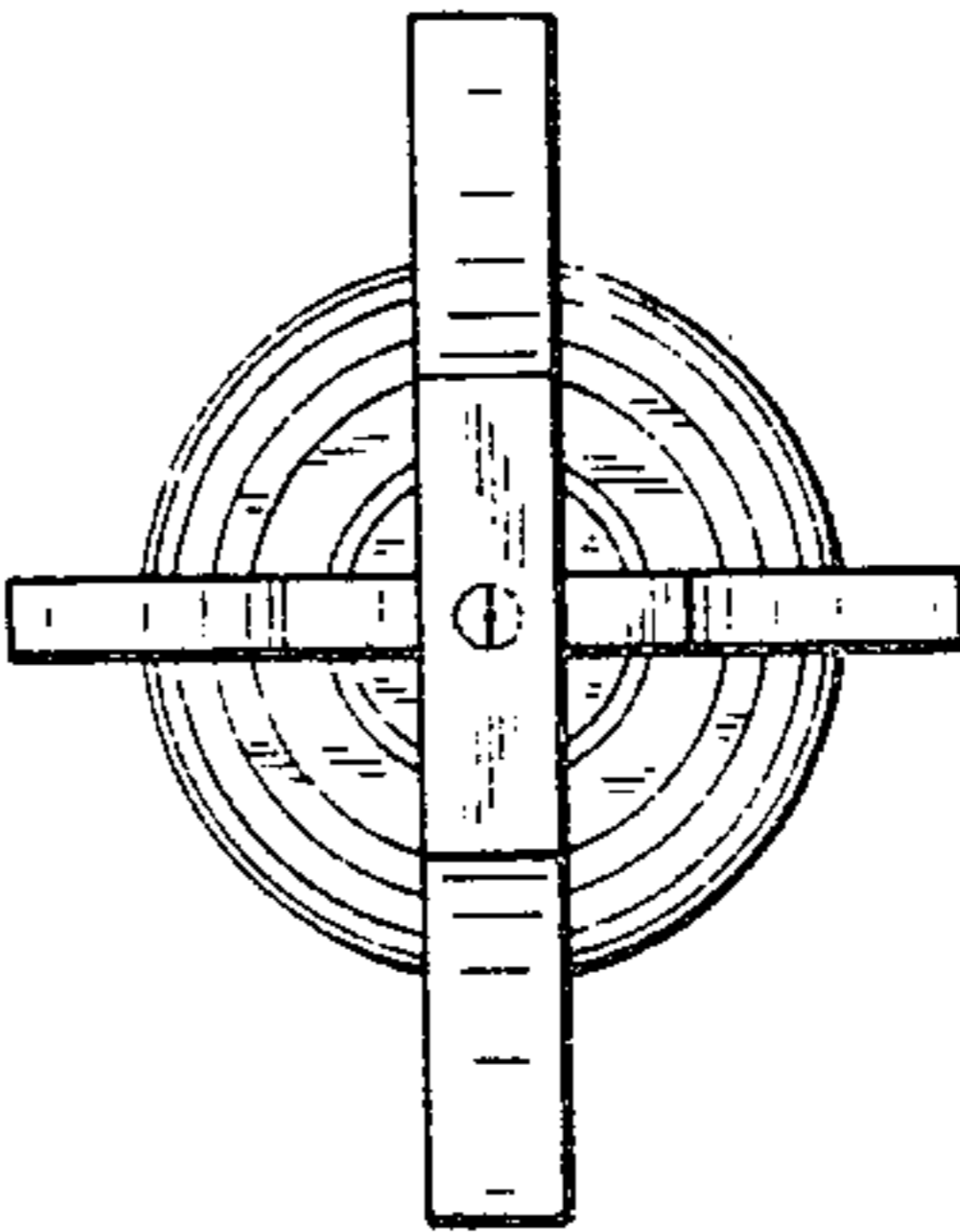

FIG. 5

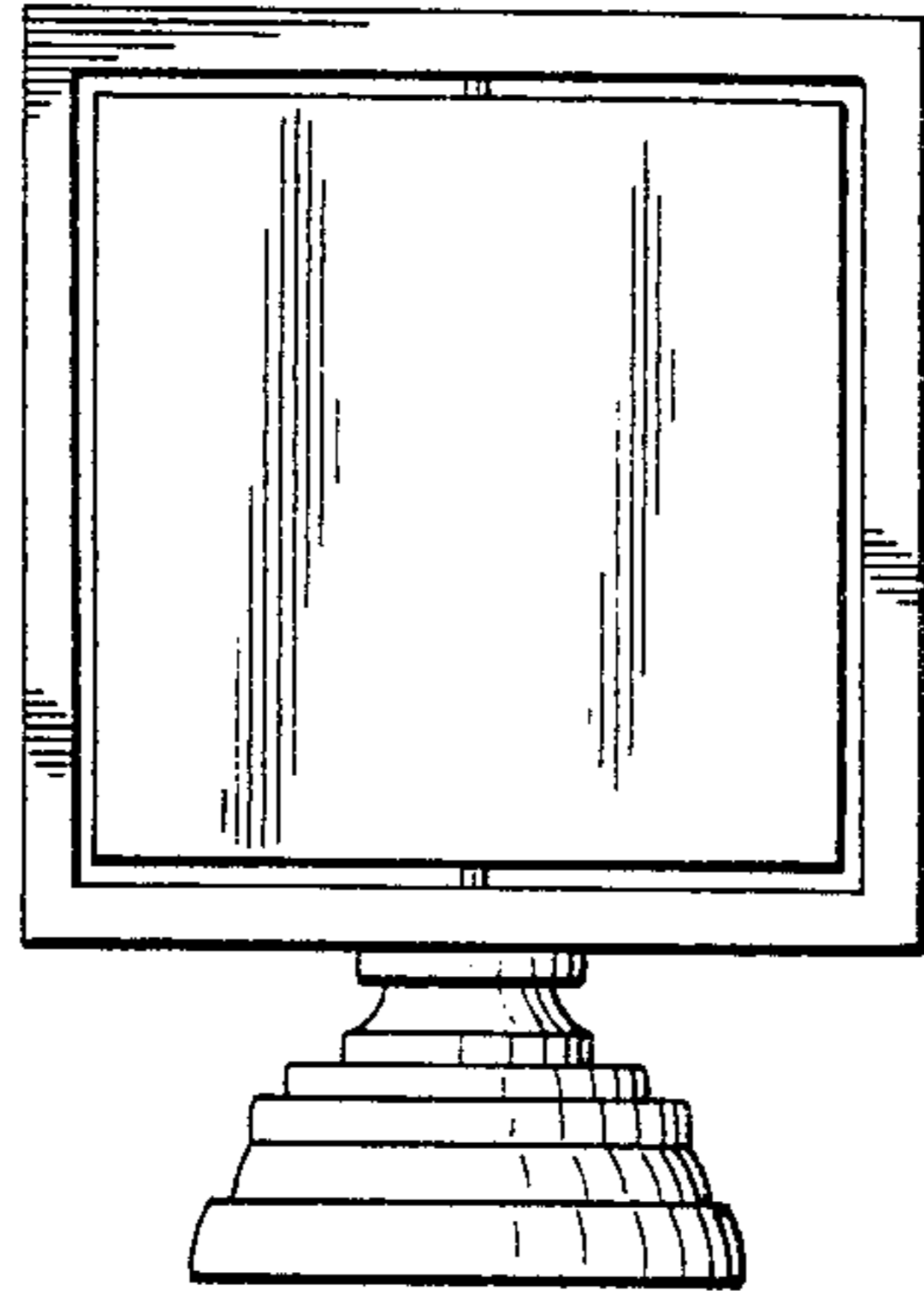

FIG. 6

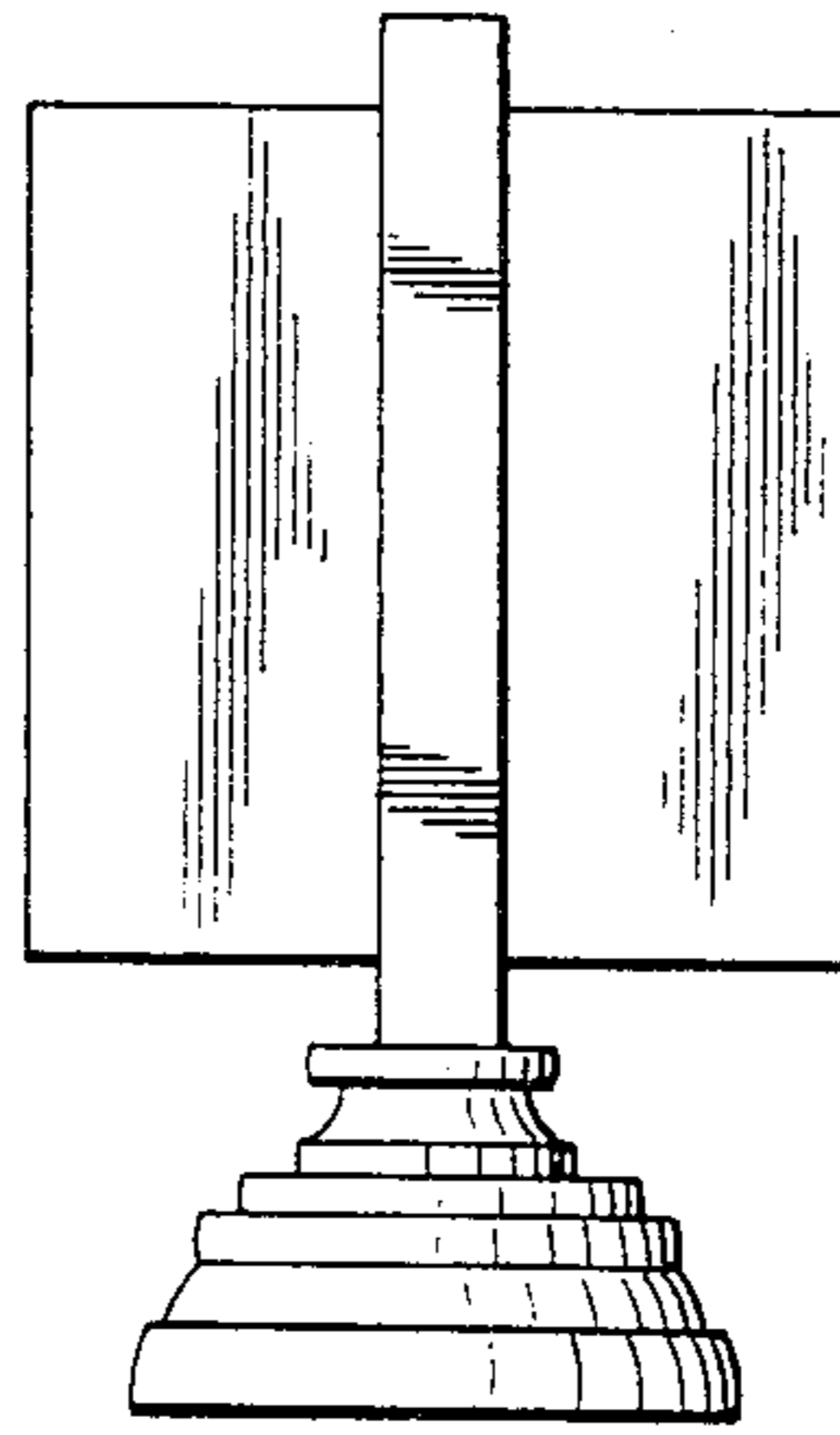

FIG. 7

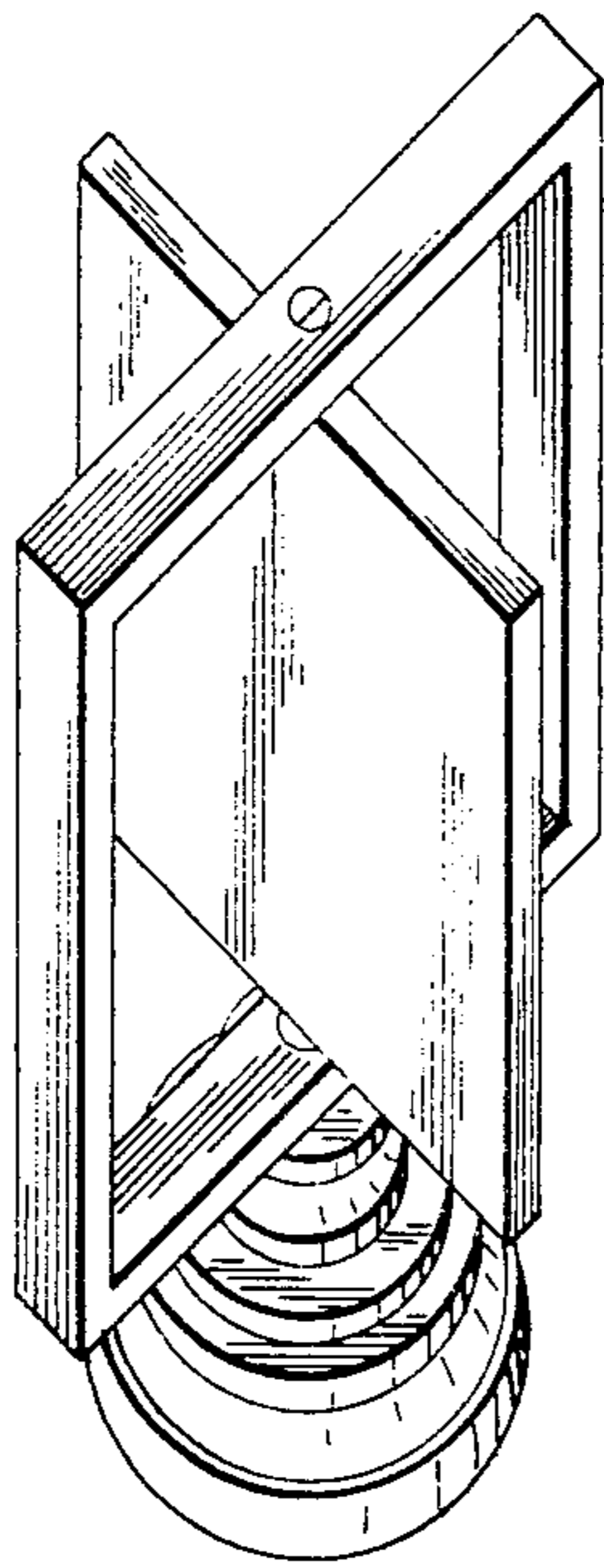
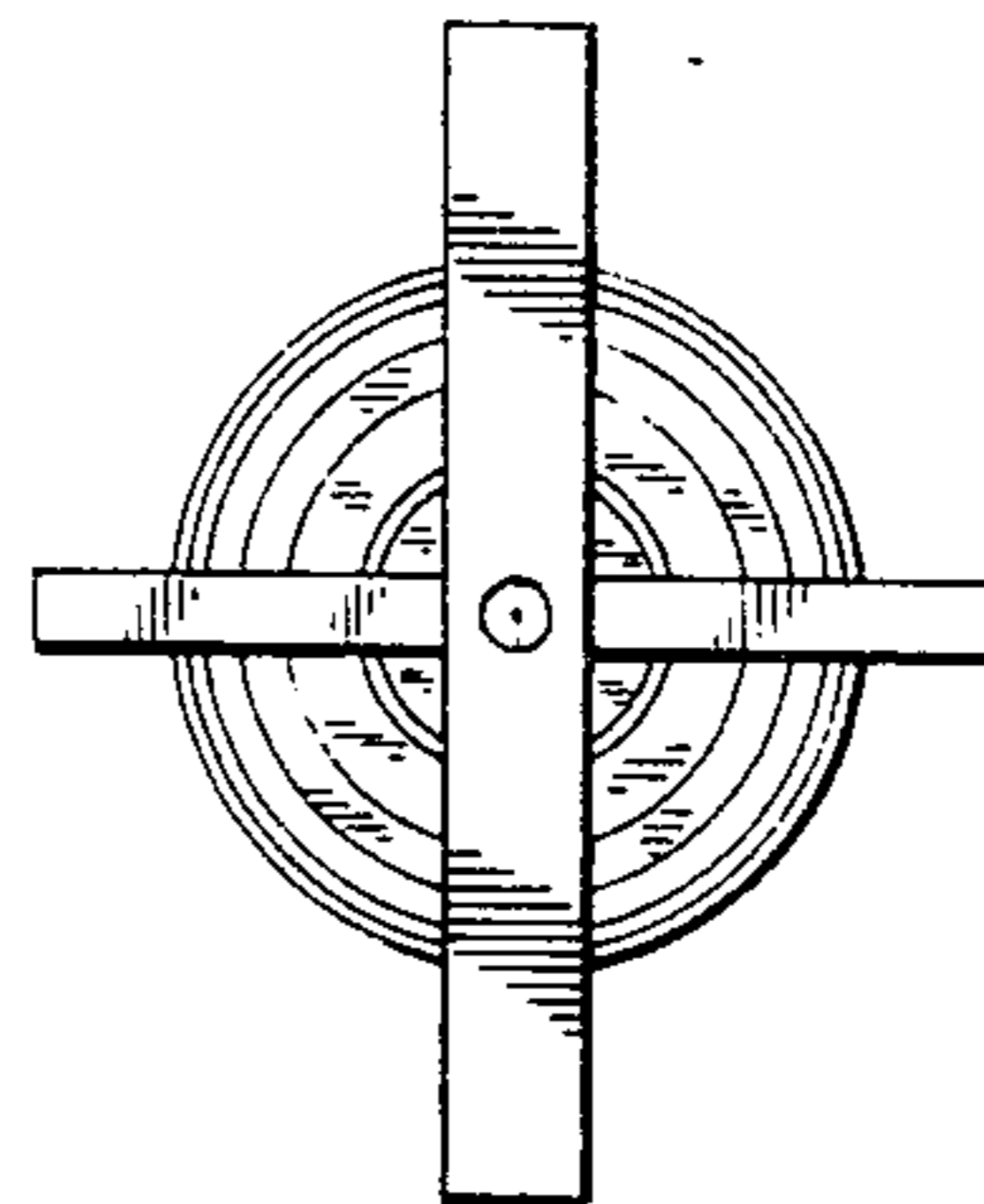

FIG. 8



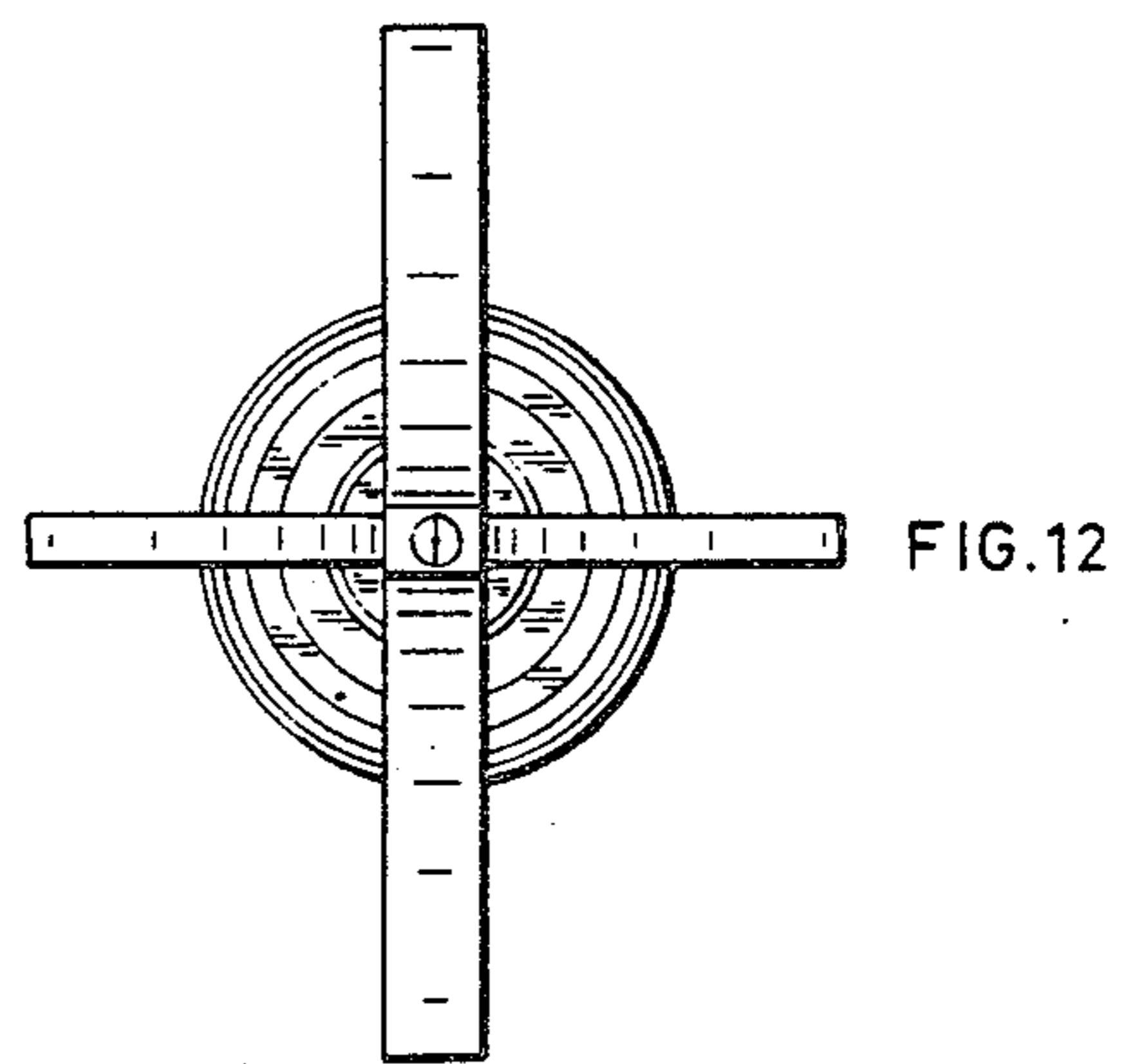
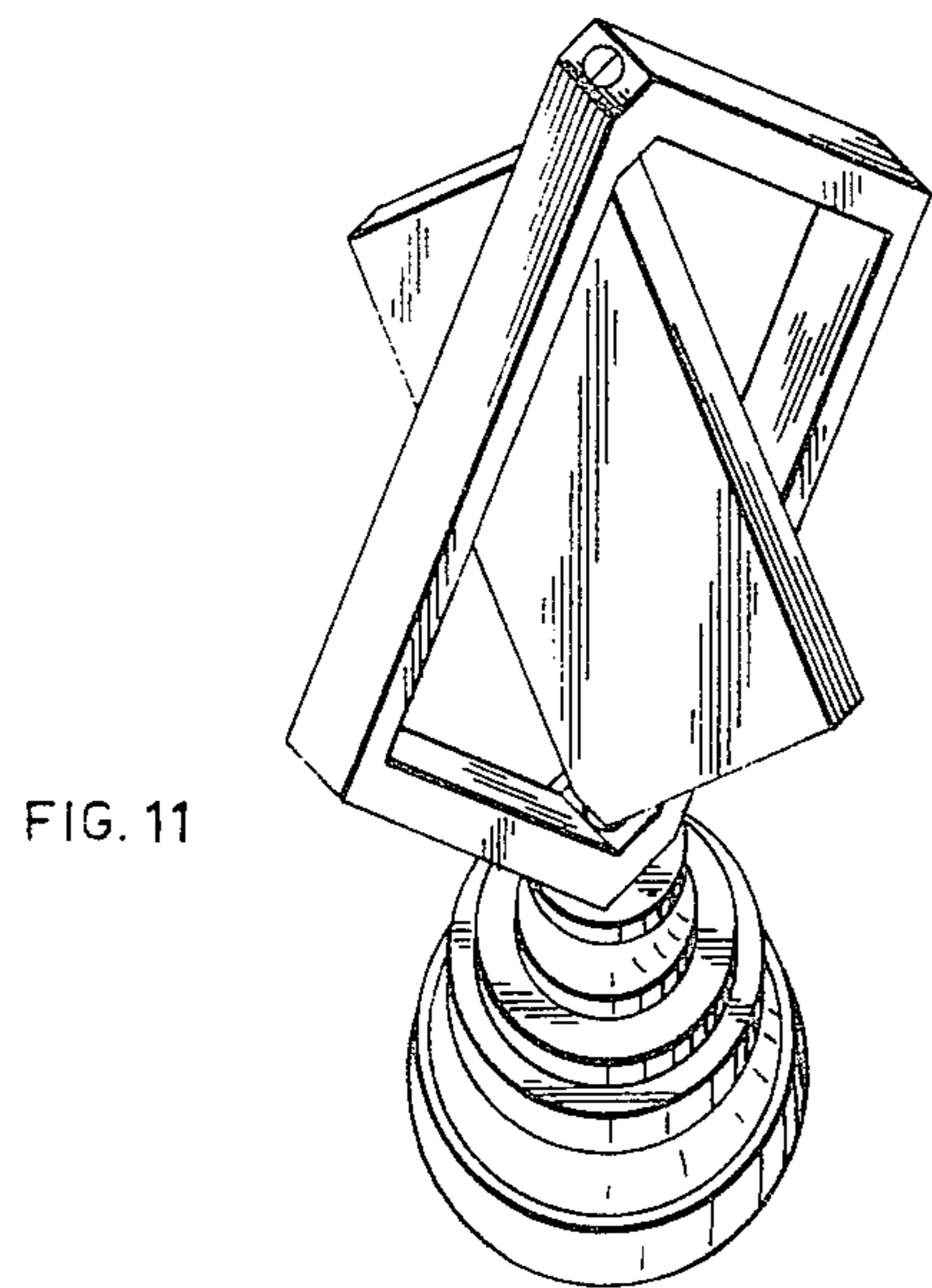
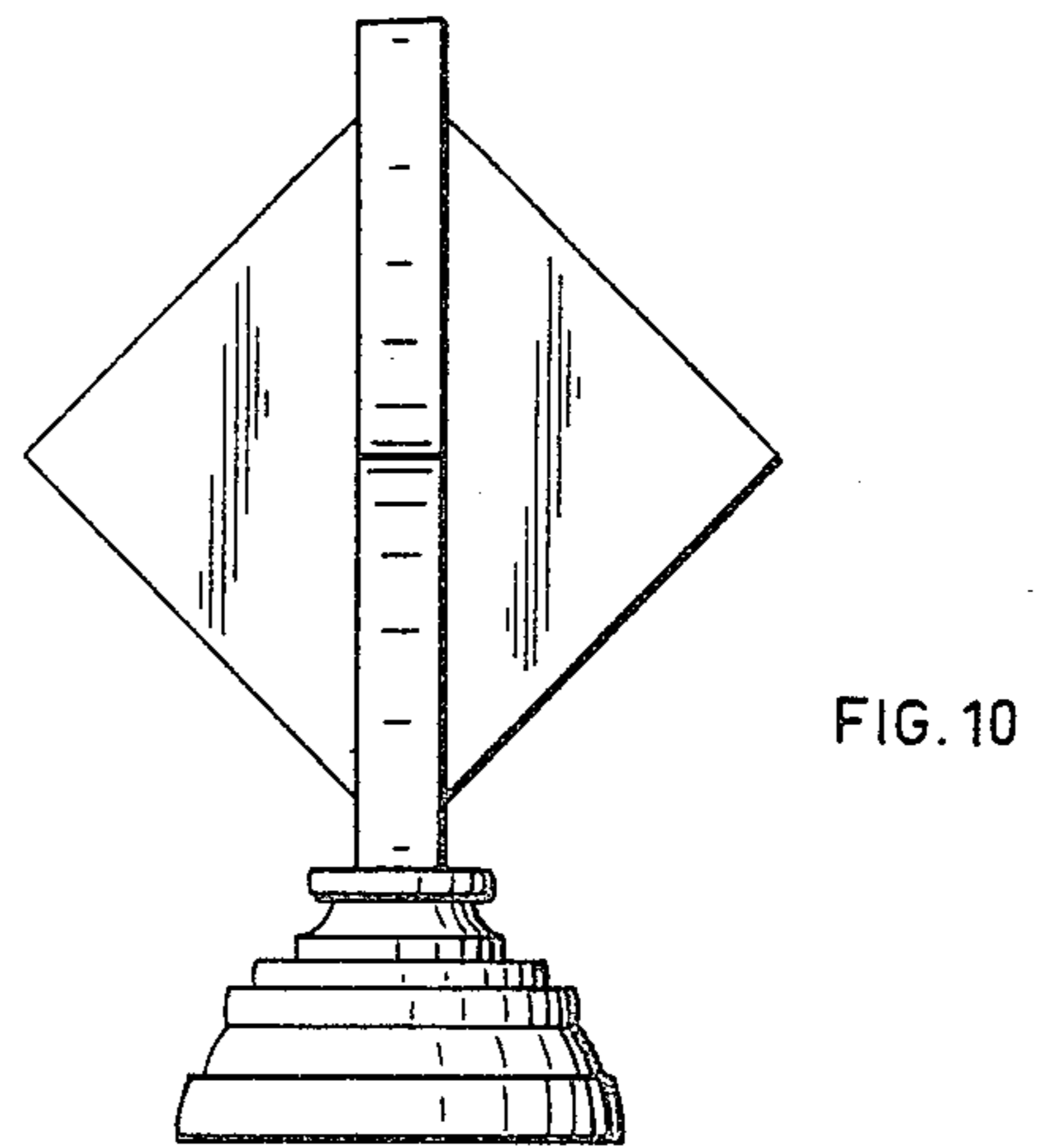
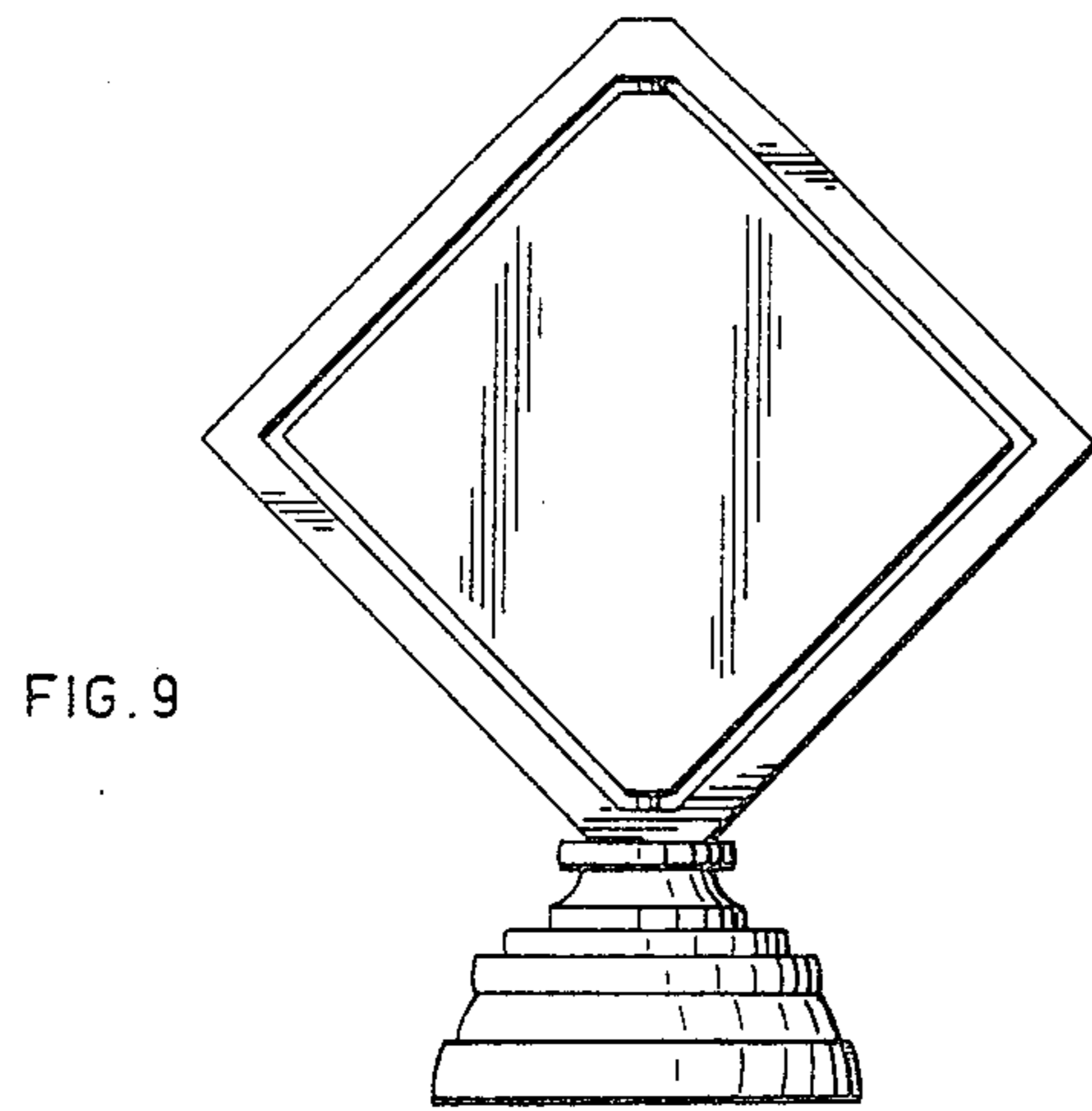

FIG. 13

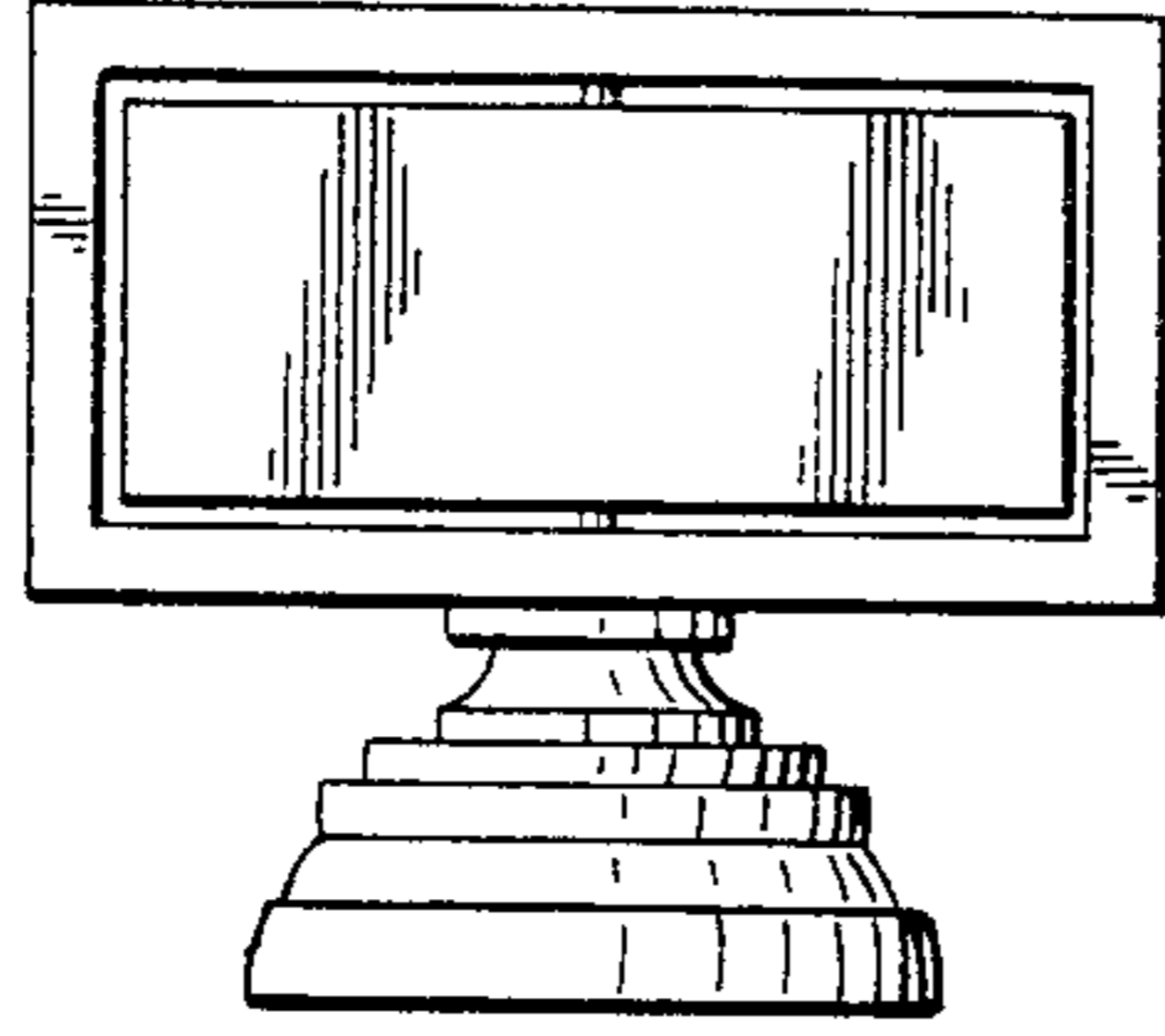

FIG. 14

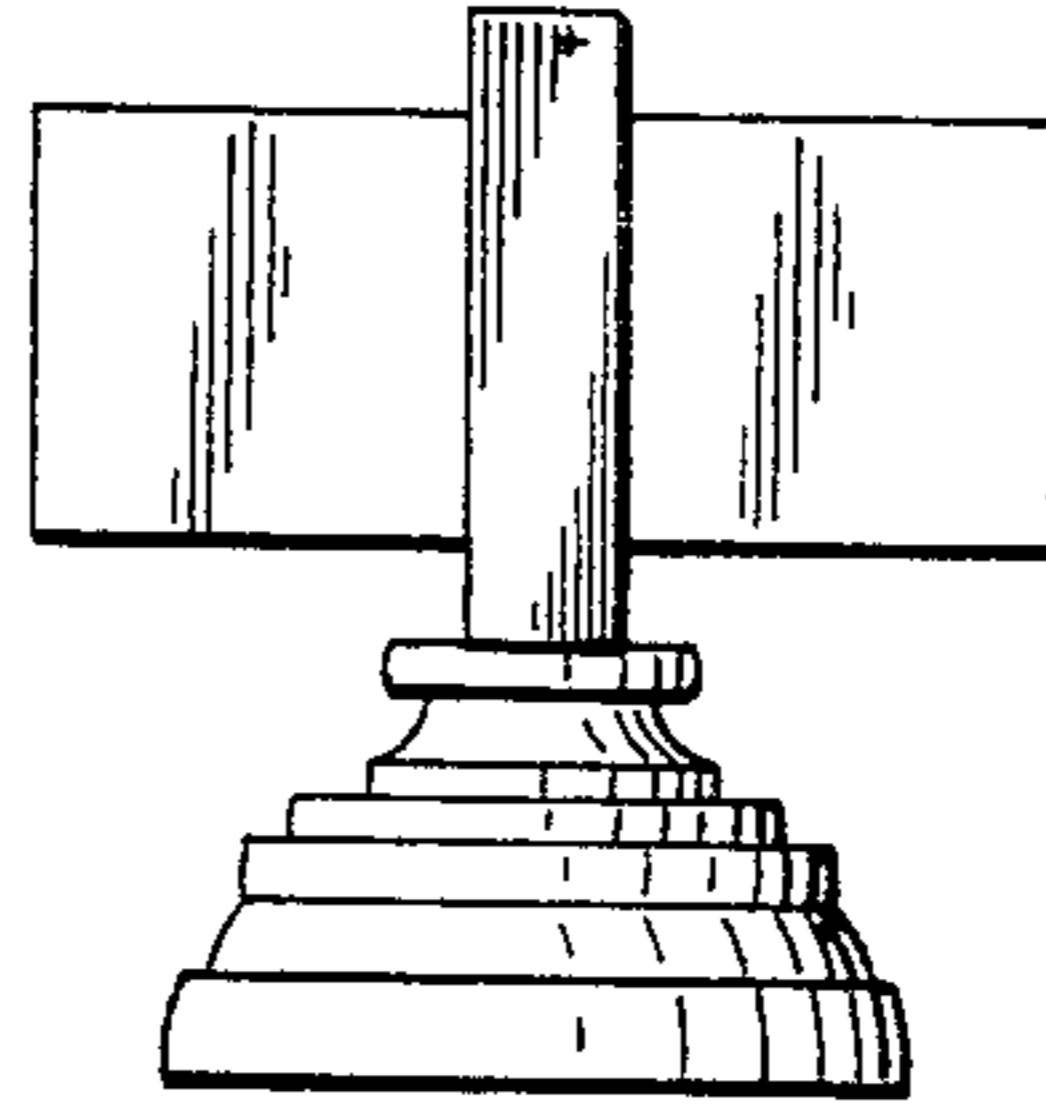

FIG. 15

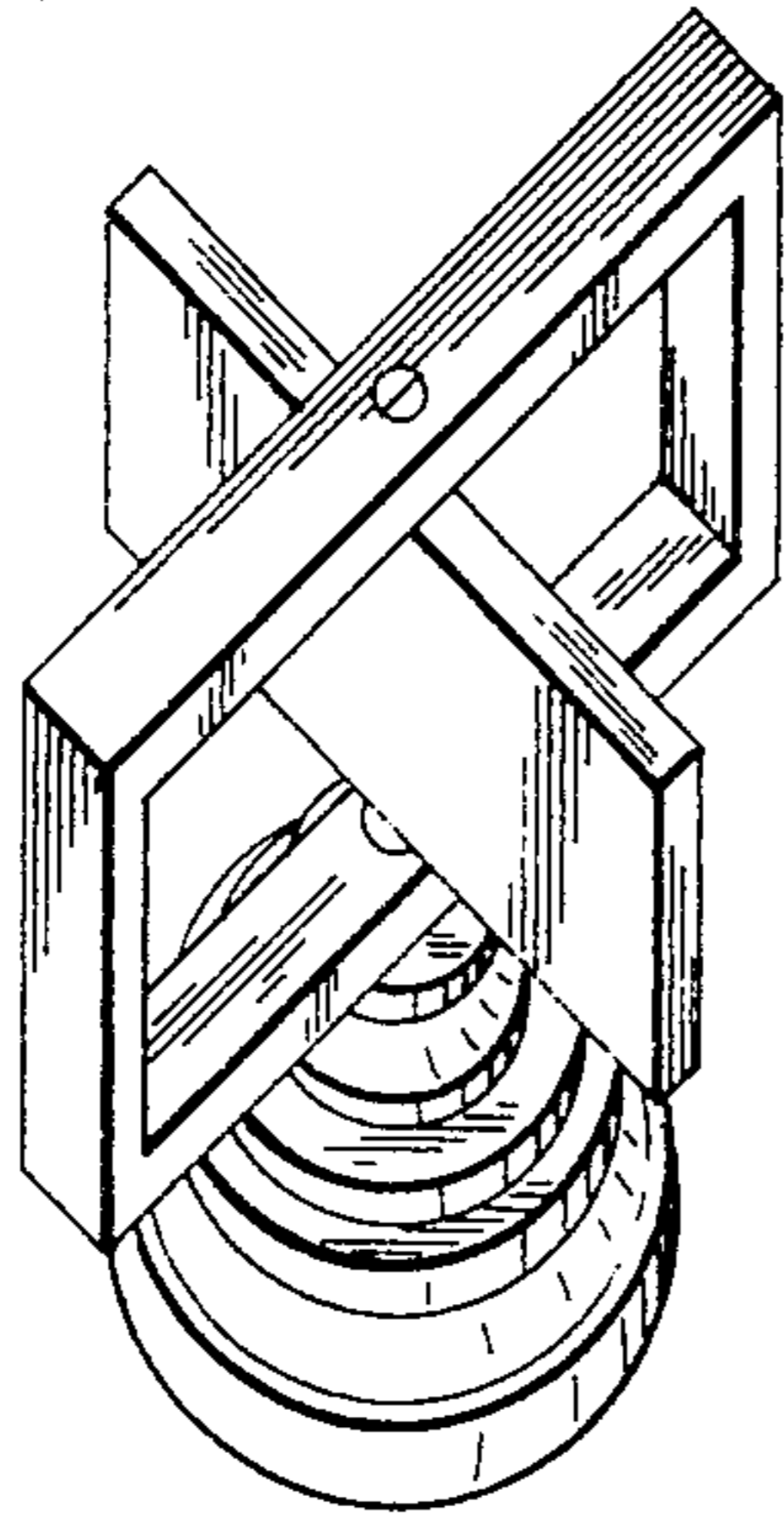

FIG. 16

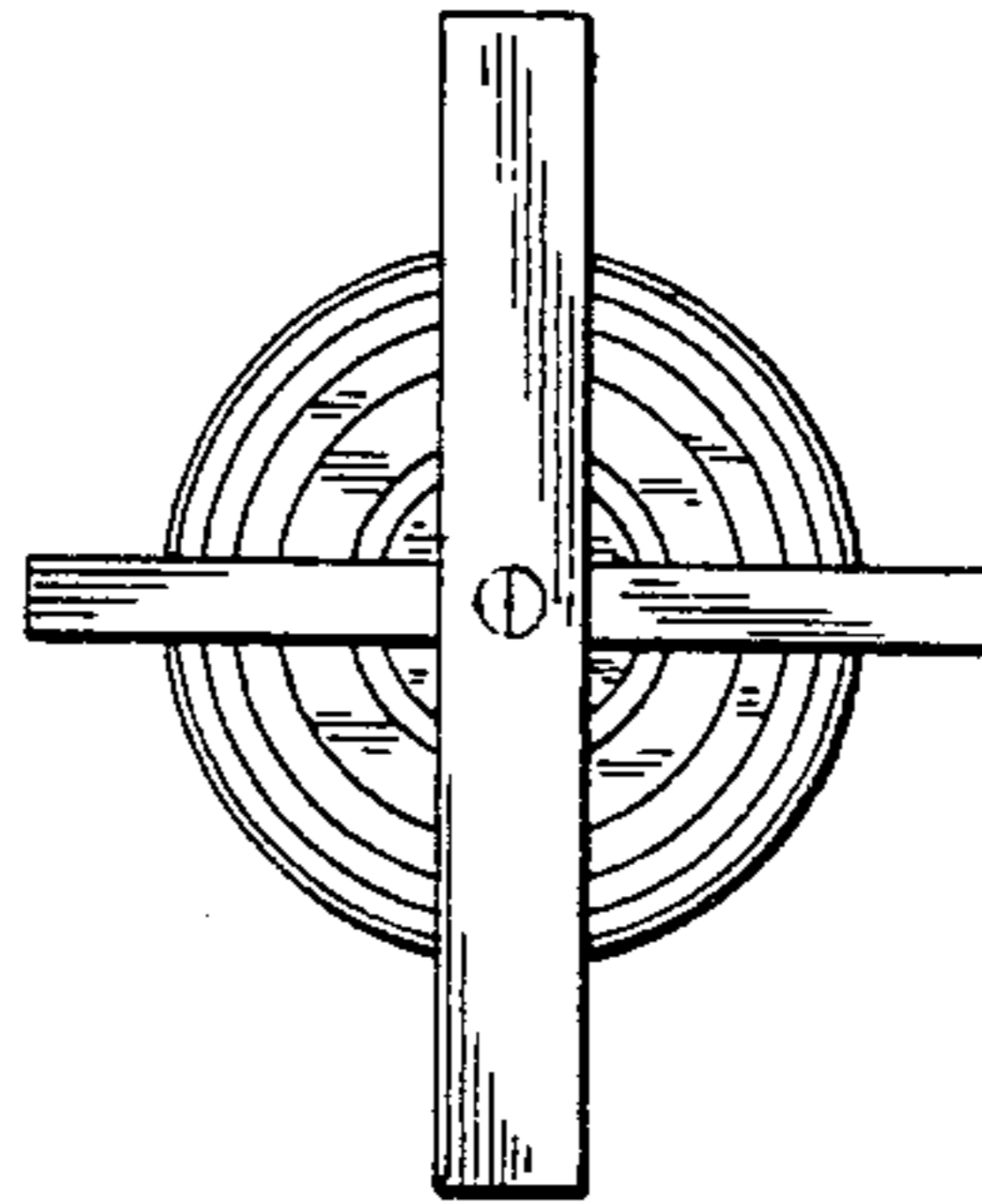

FIG. 17

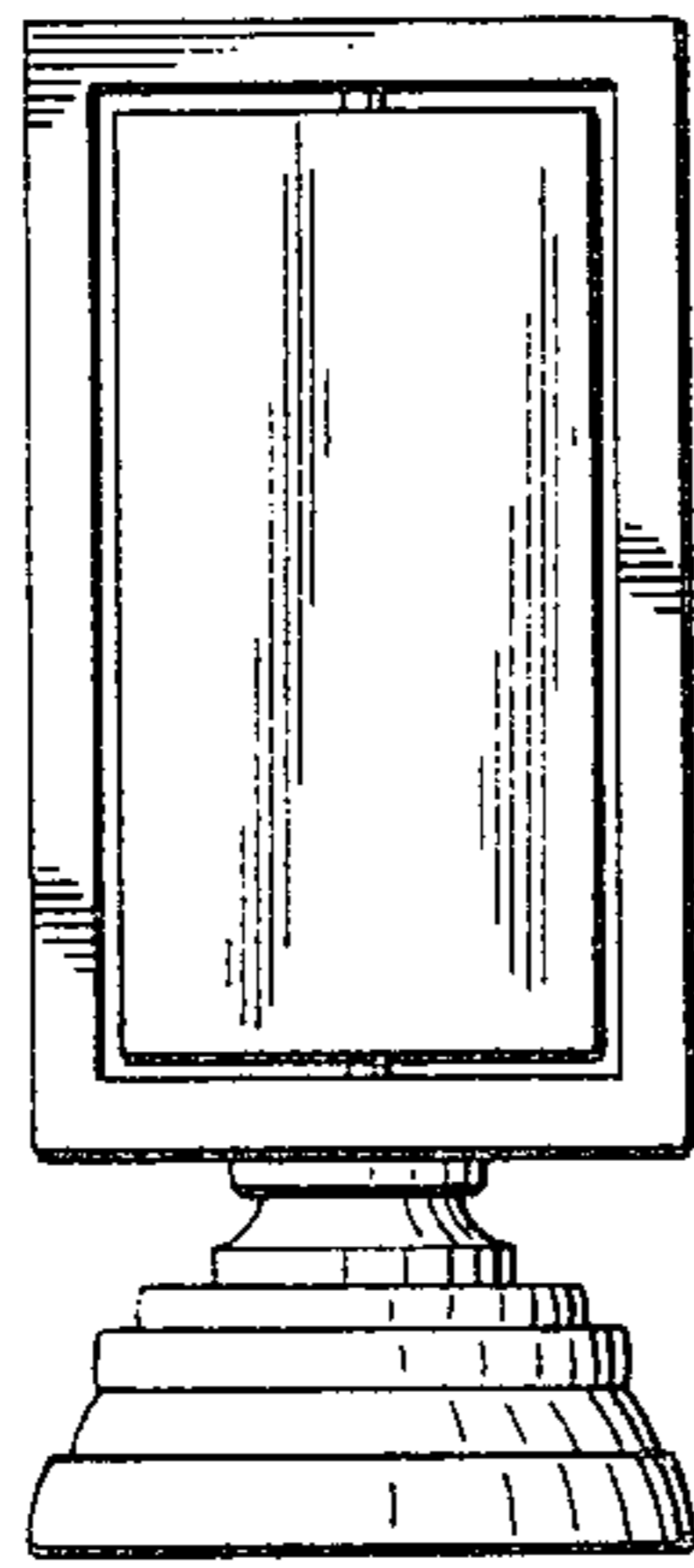

FIG. 18

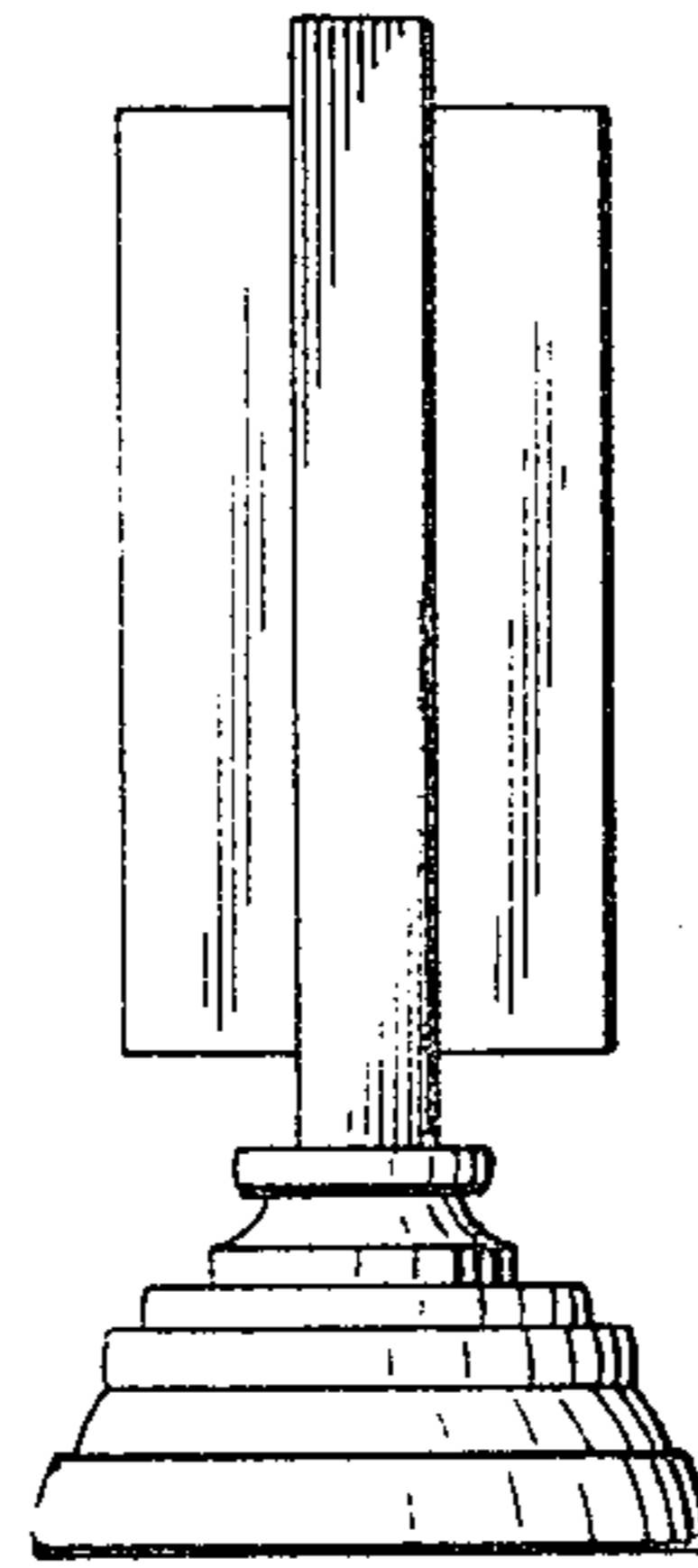

FIG. 19

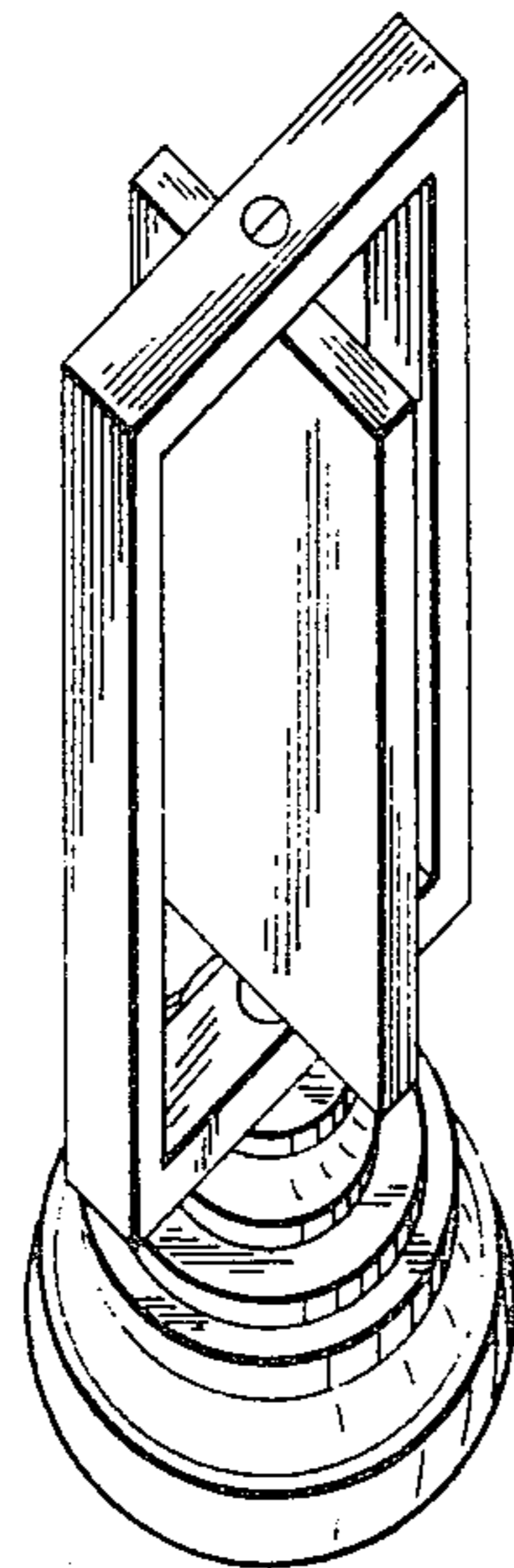

FIG. 20

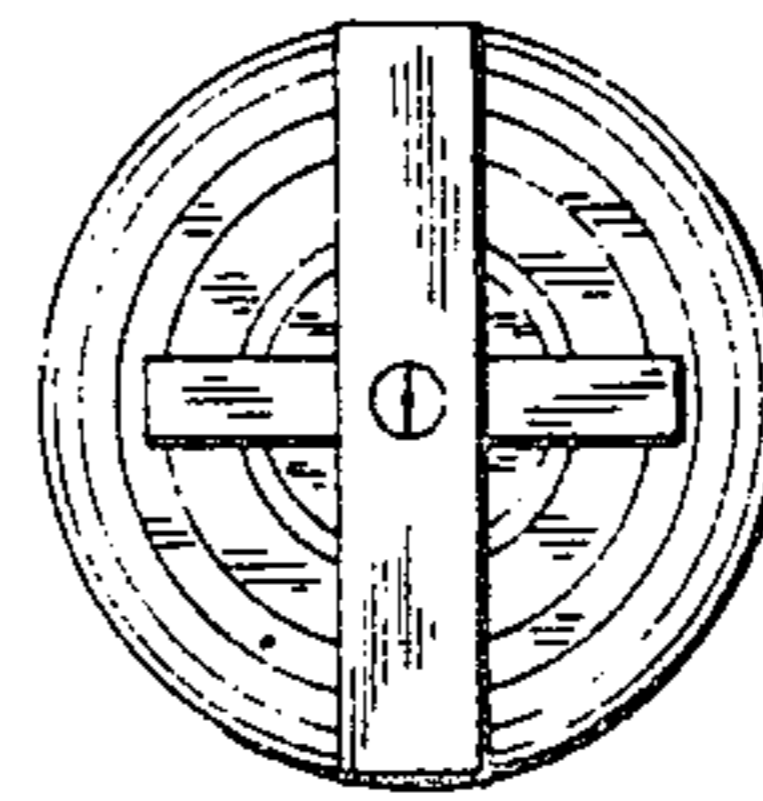

FIG. 21

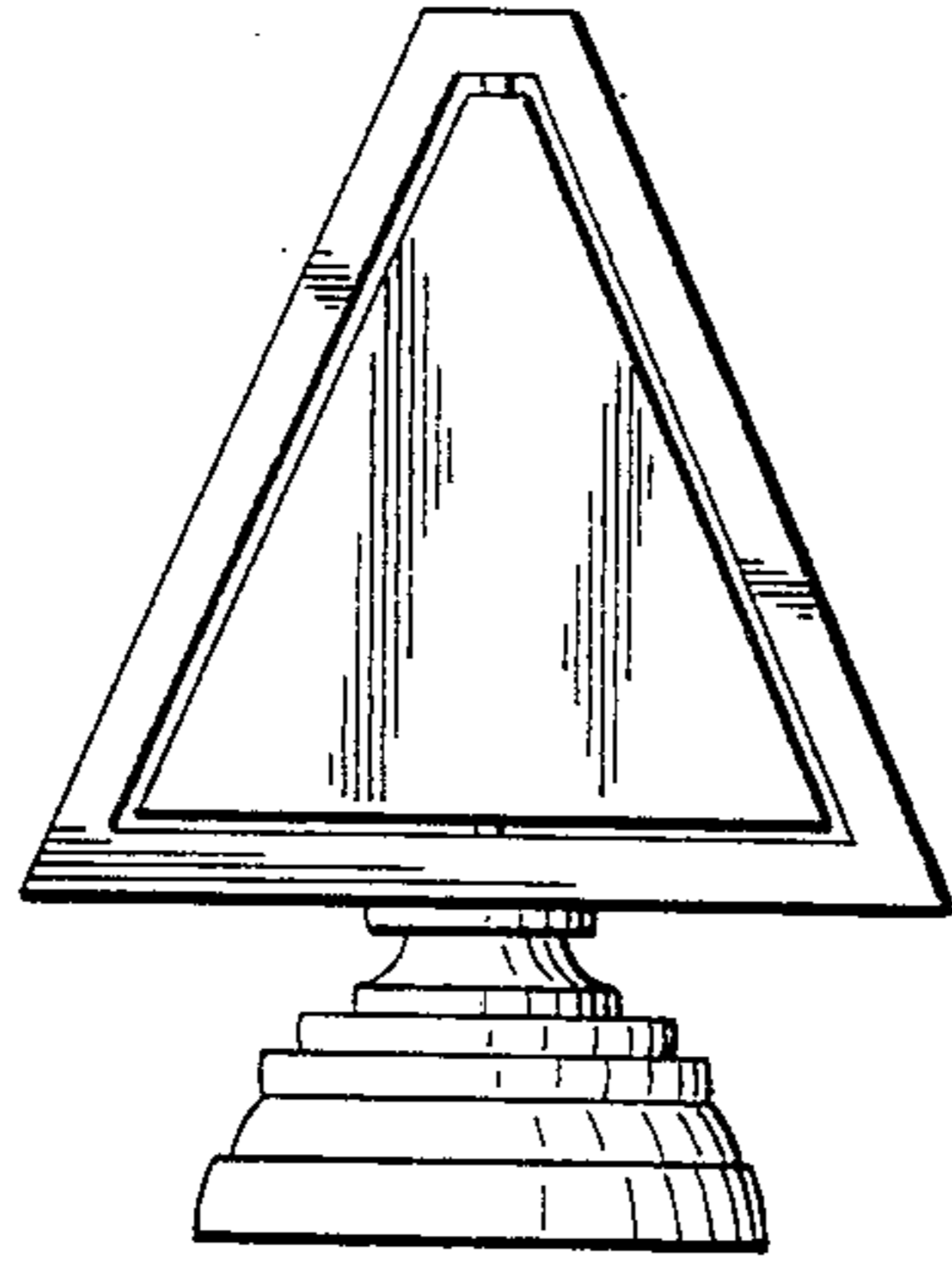

FIG. 22

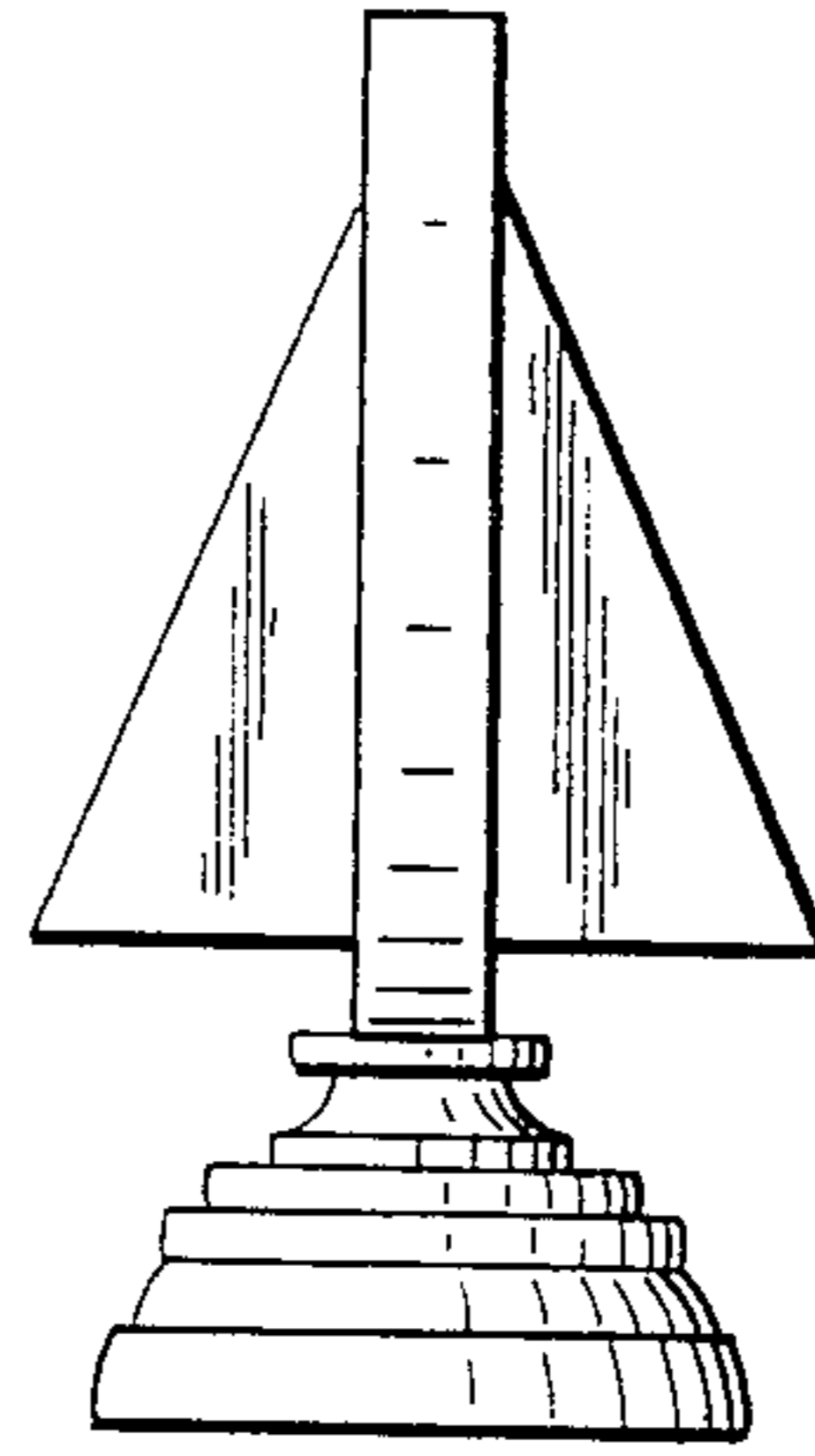

FIG. 23

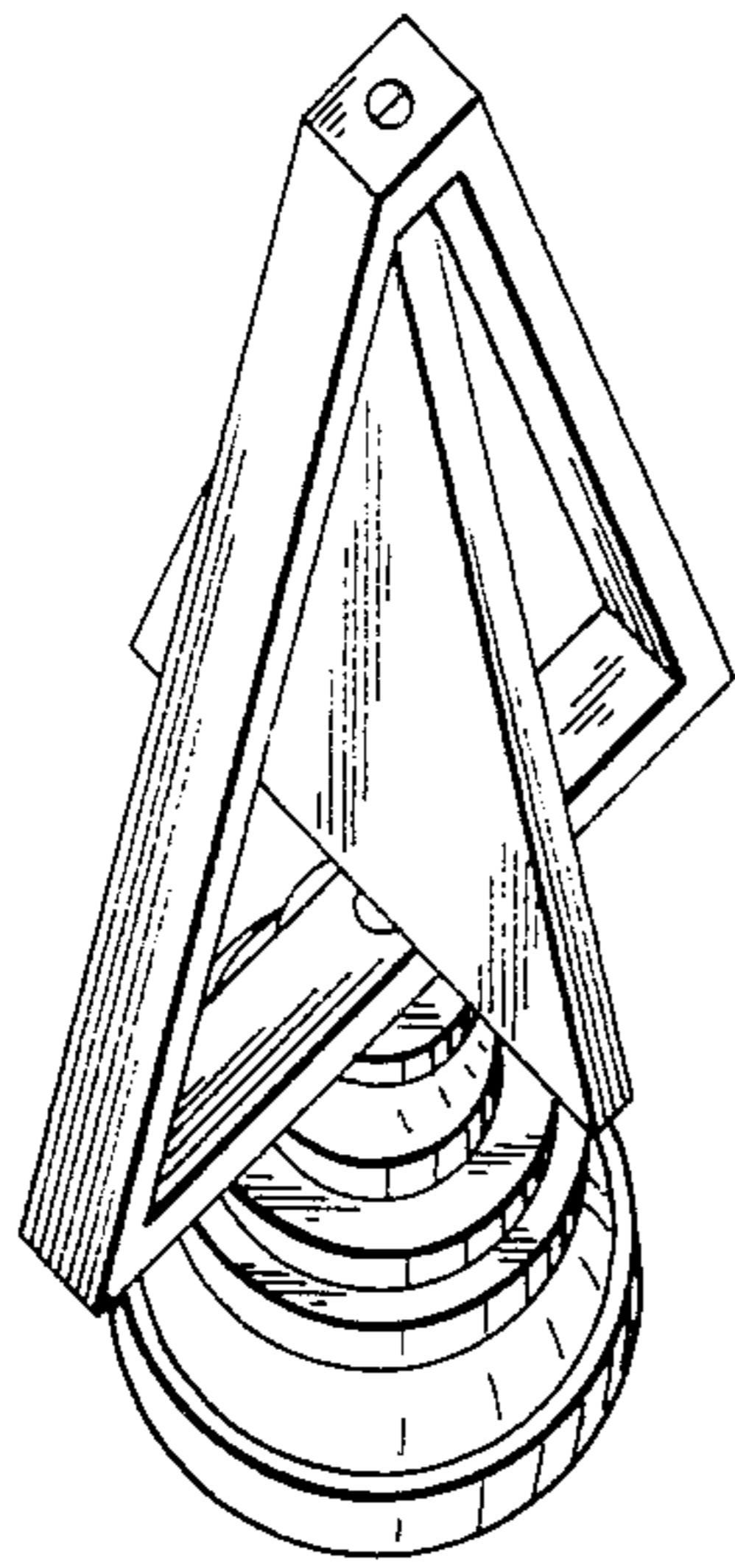

FIG. 24

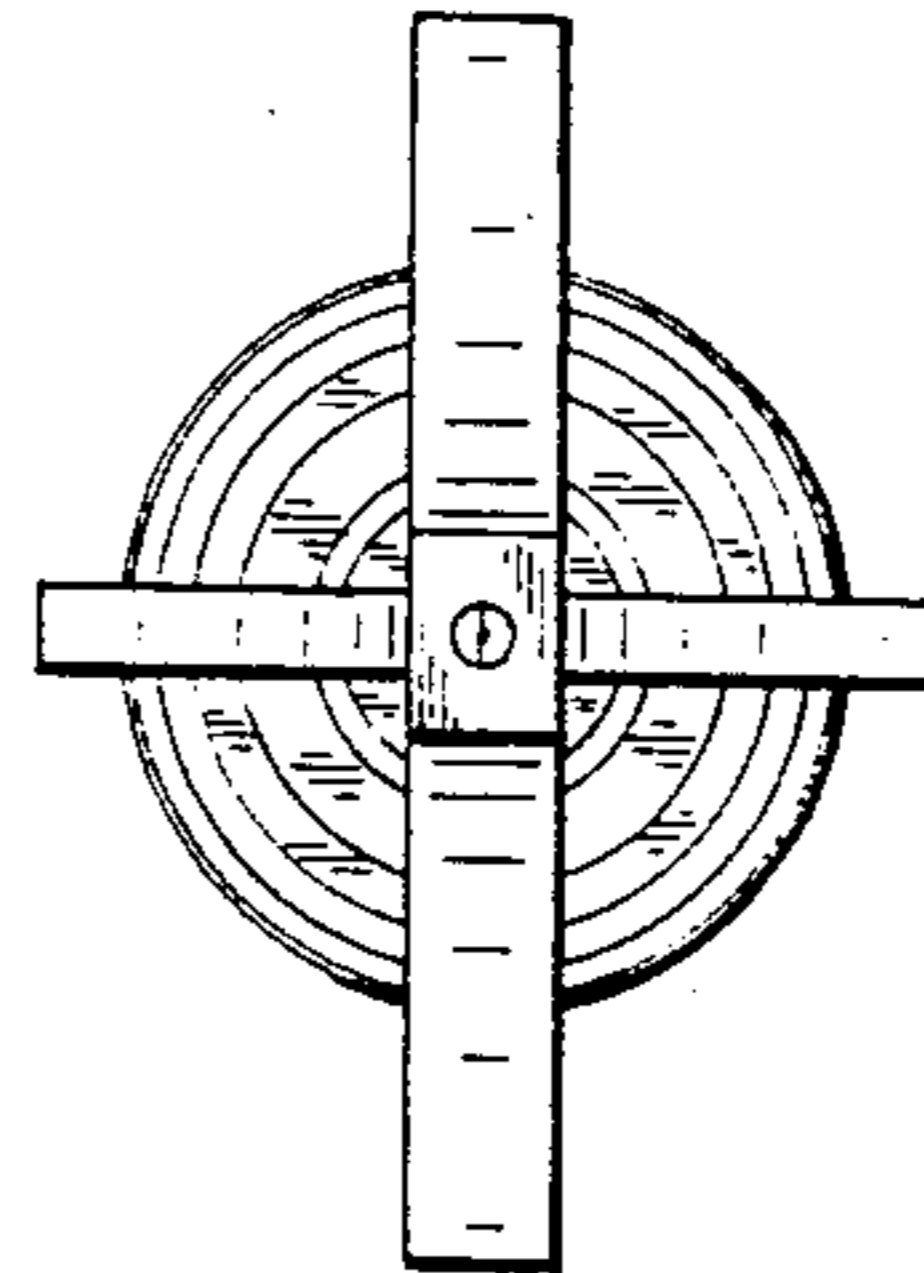

FIG. 25

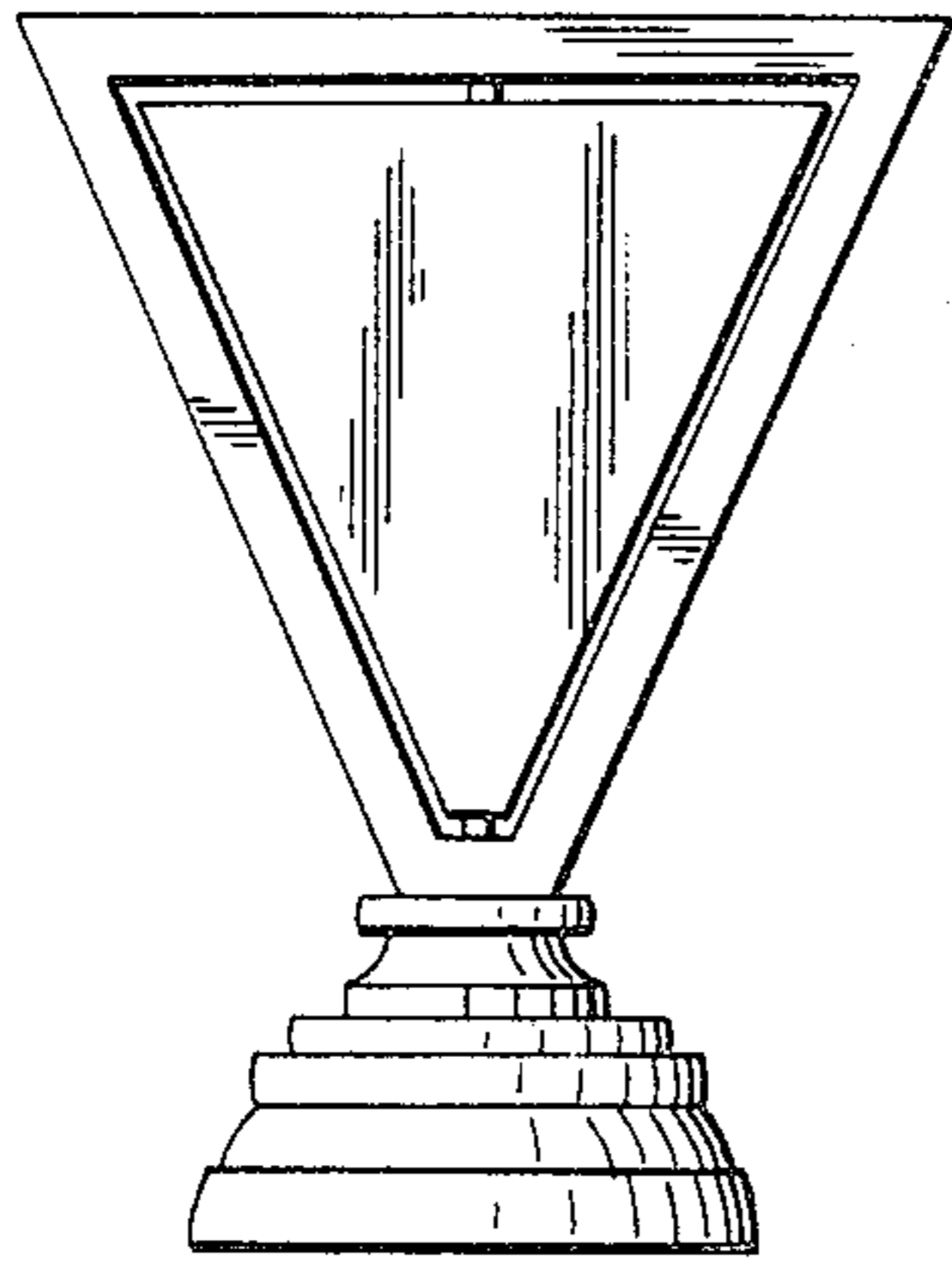

FIG. 26

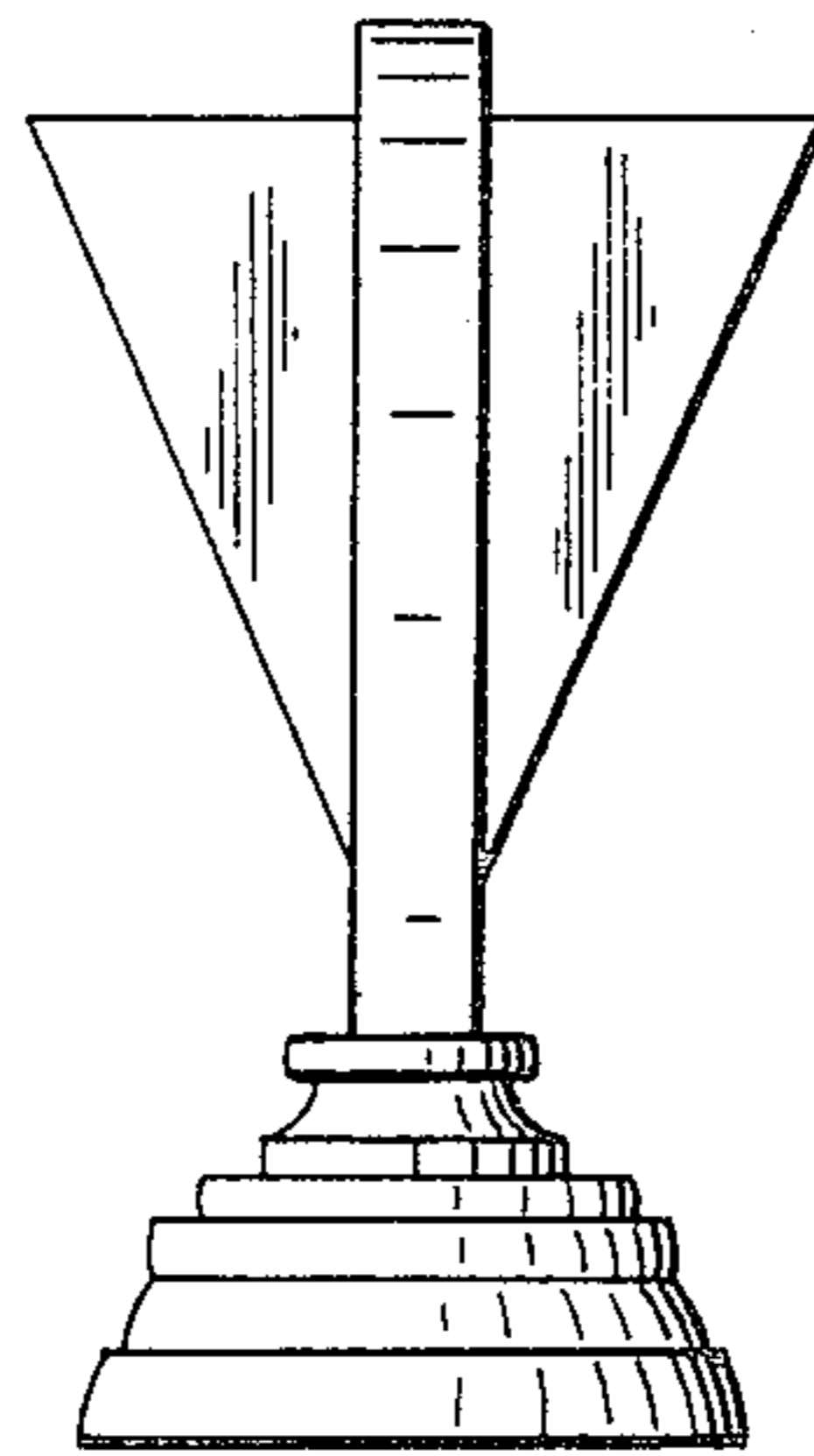

FIG. 27

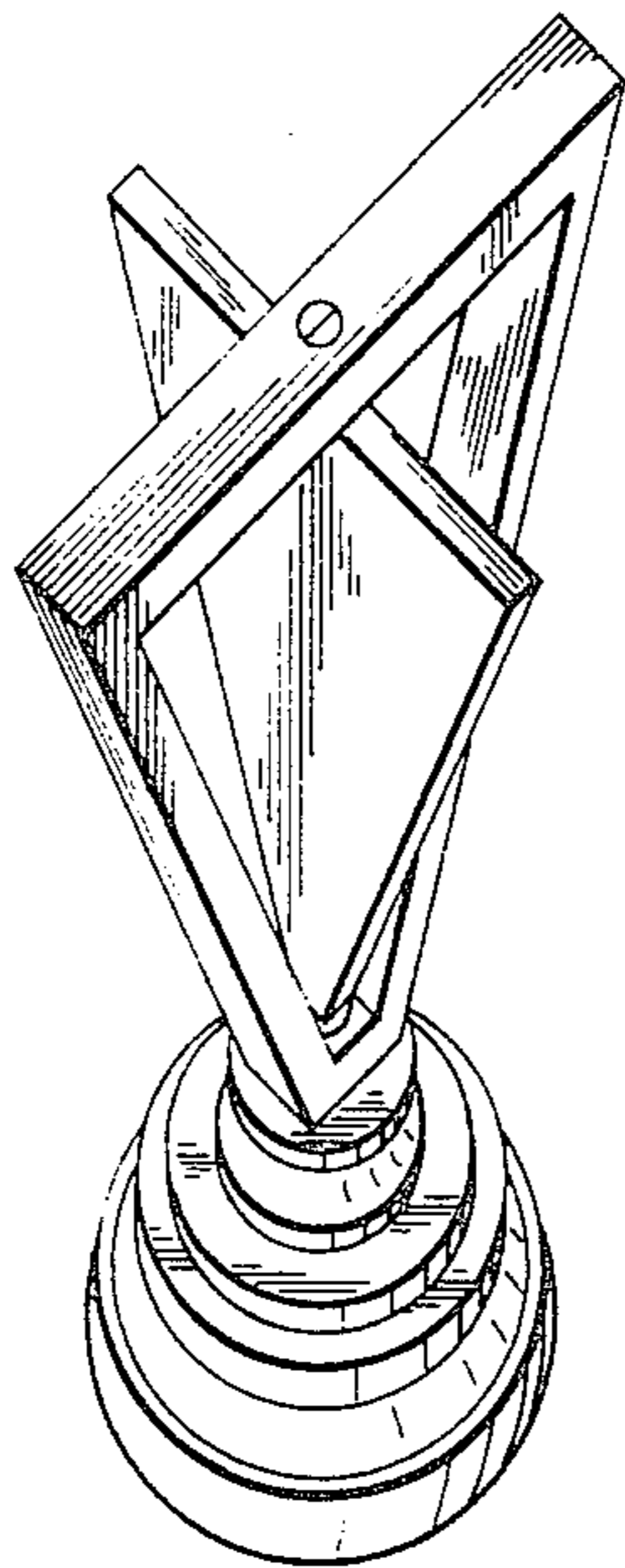

FIG. 28

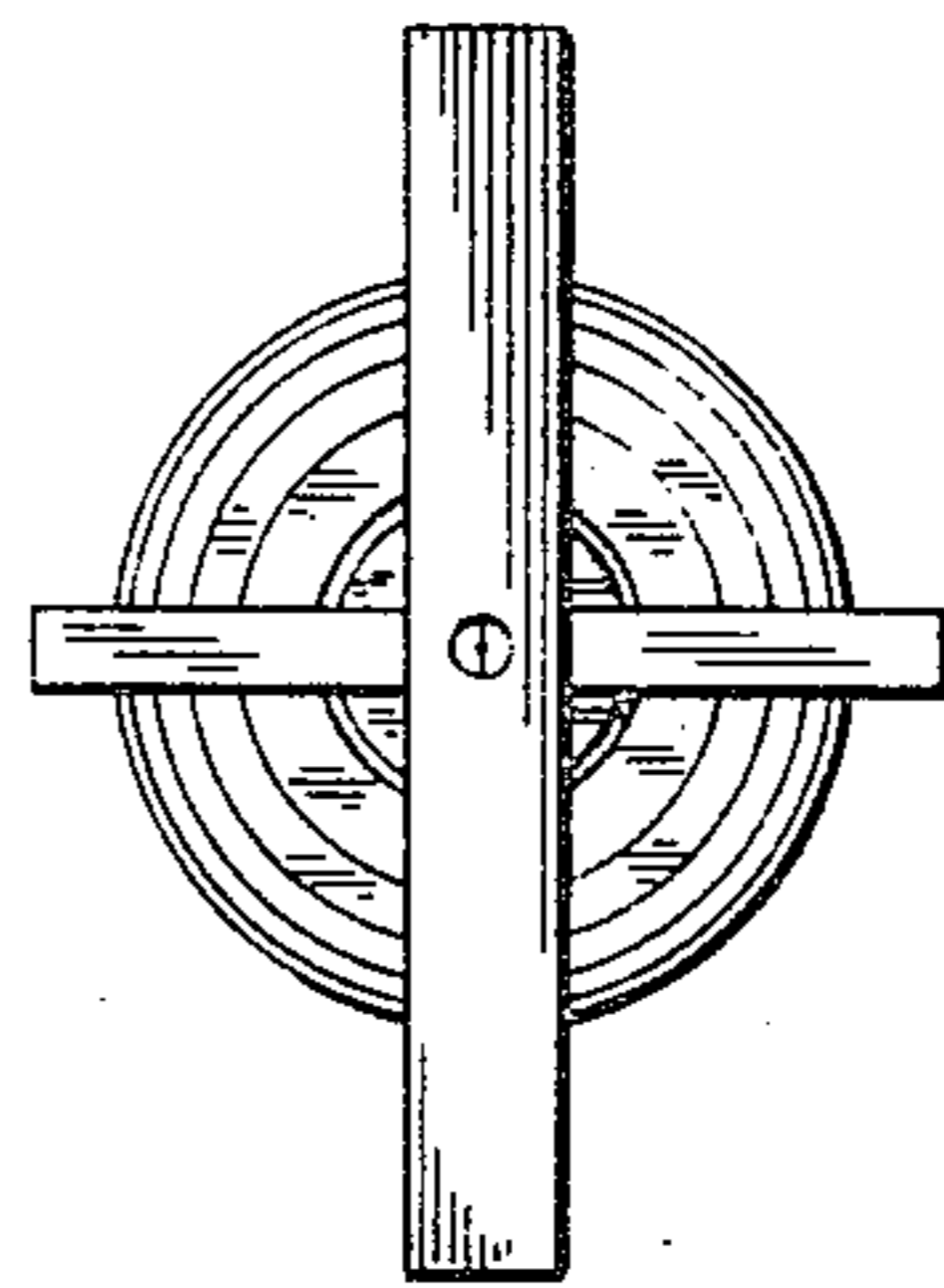



FIG. 29

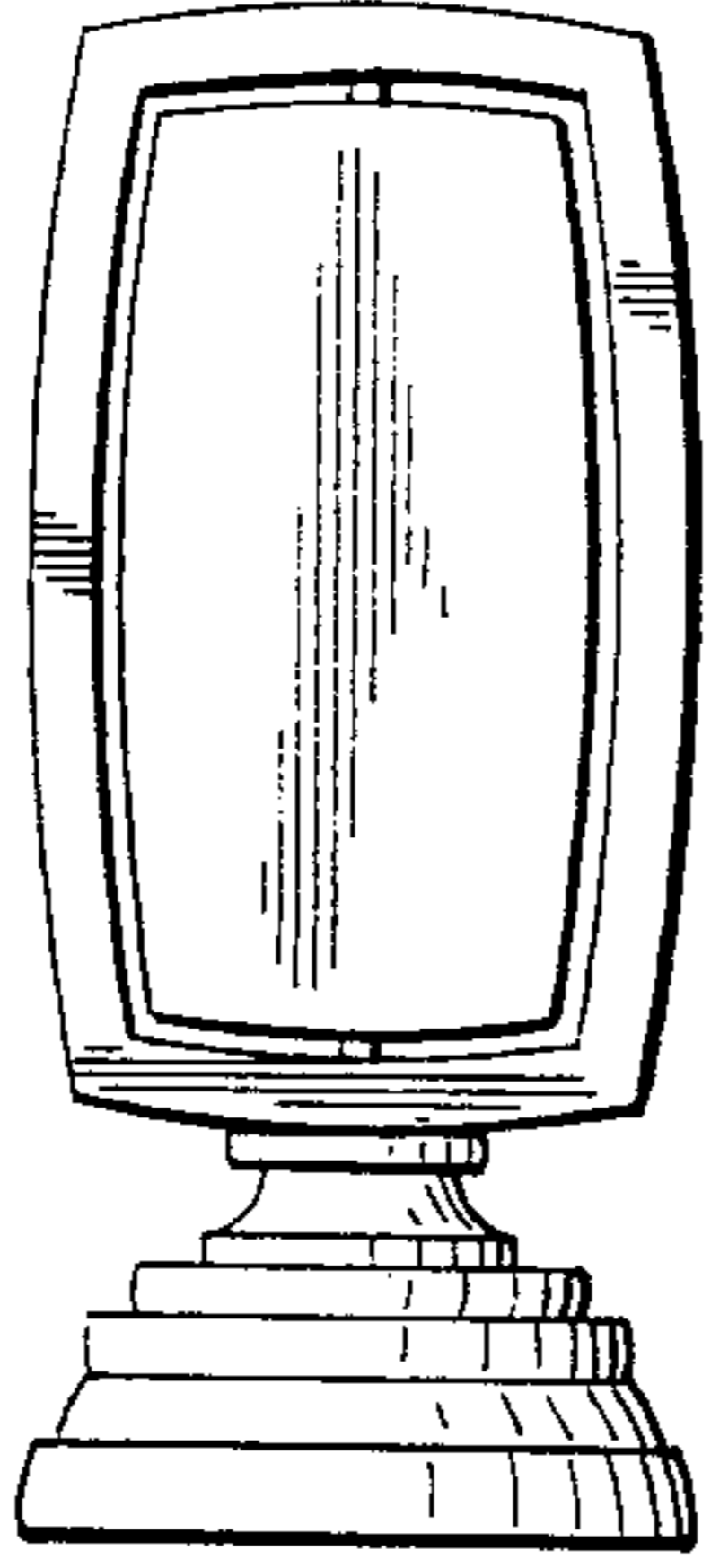

FIG. 30

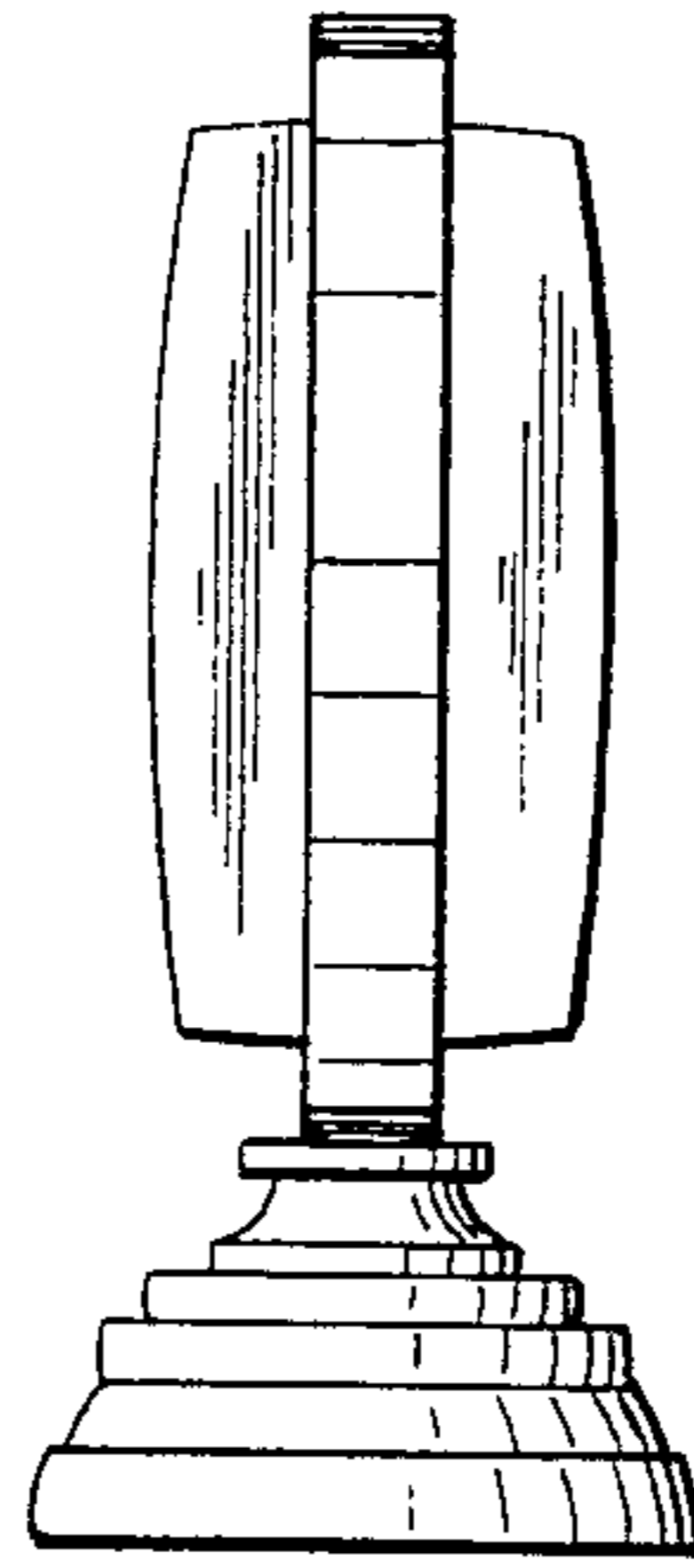

FIG. 31

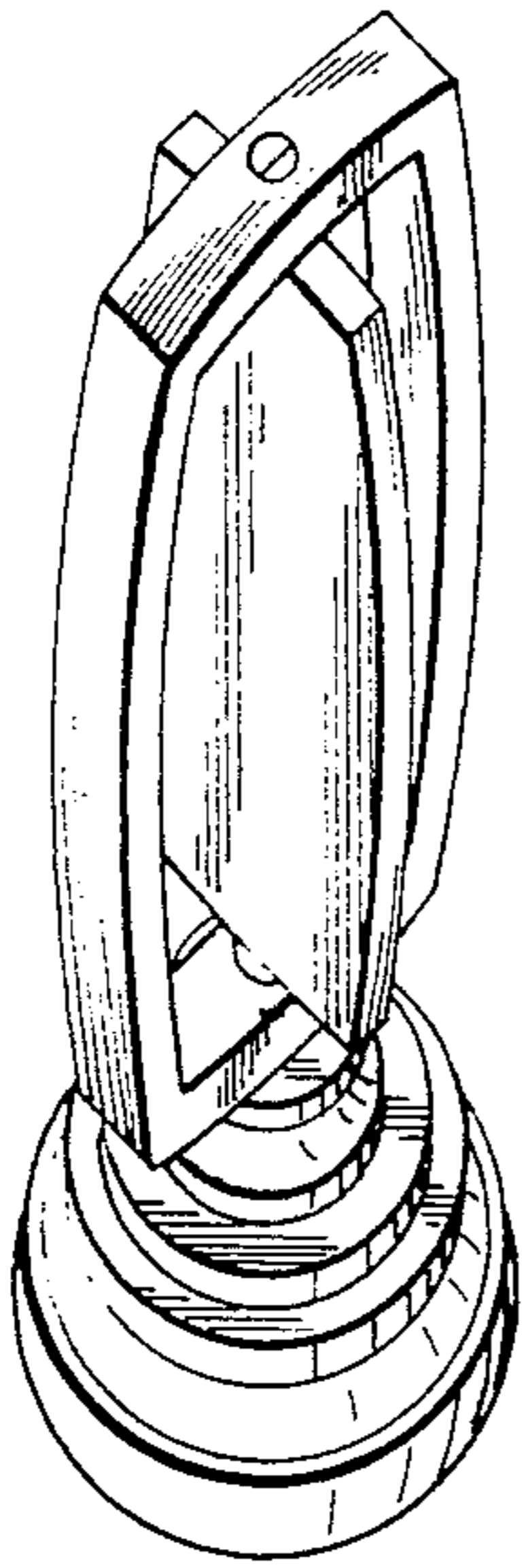

FIG. 32

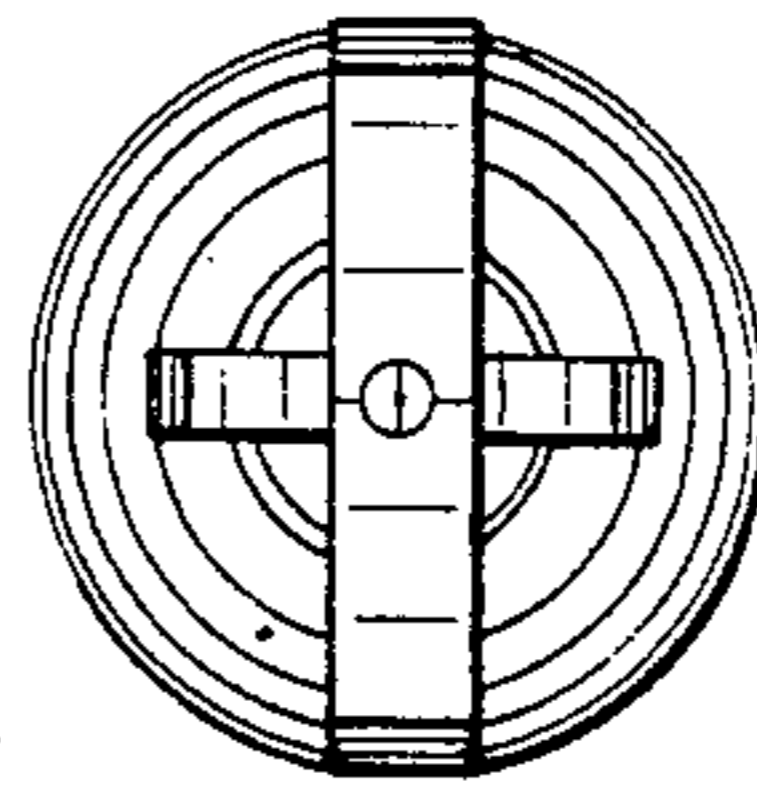

FIG. 33

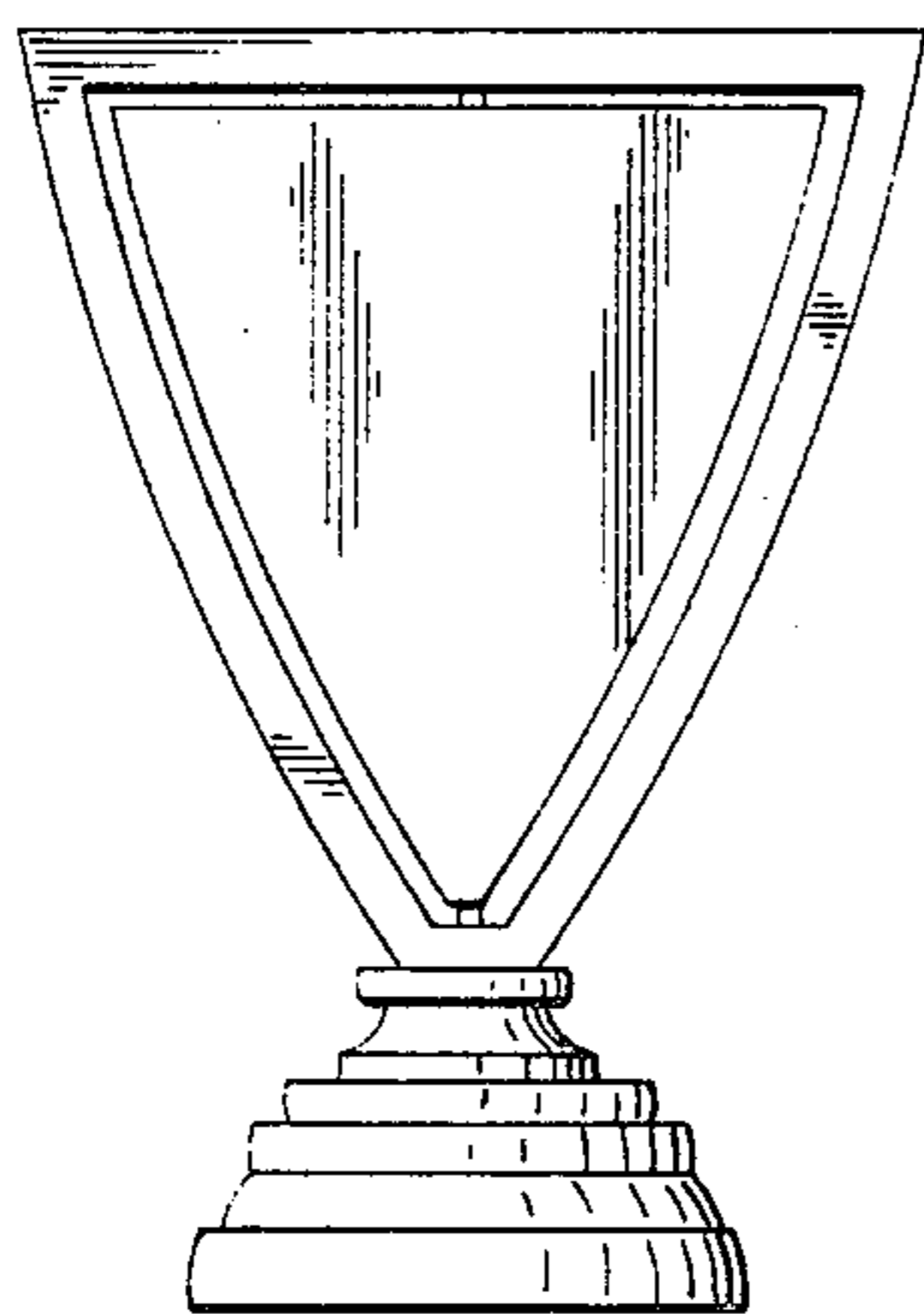

FIG. 34

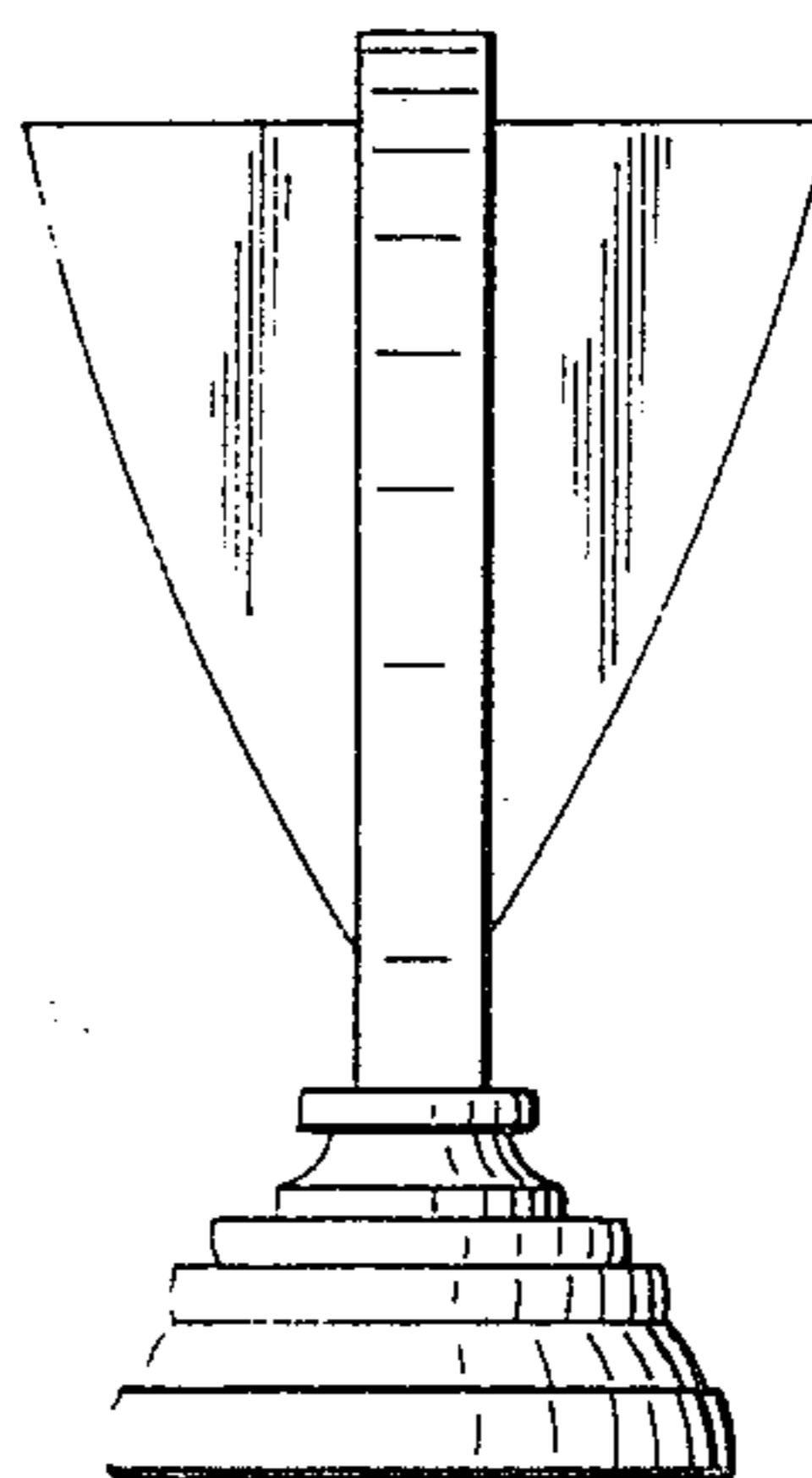

FIG. 35

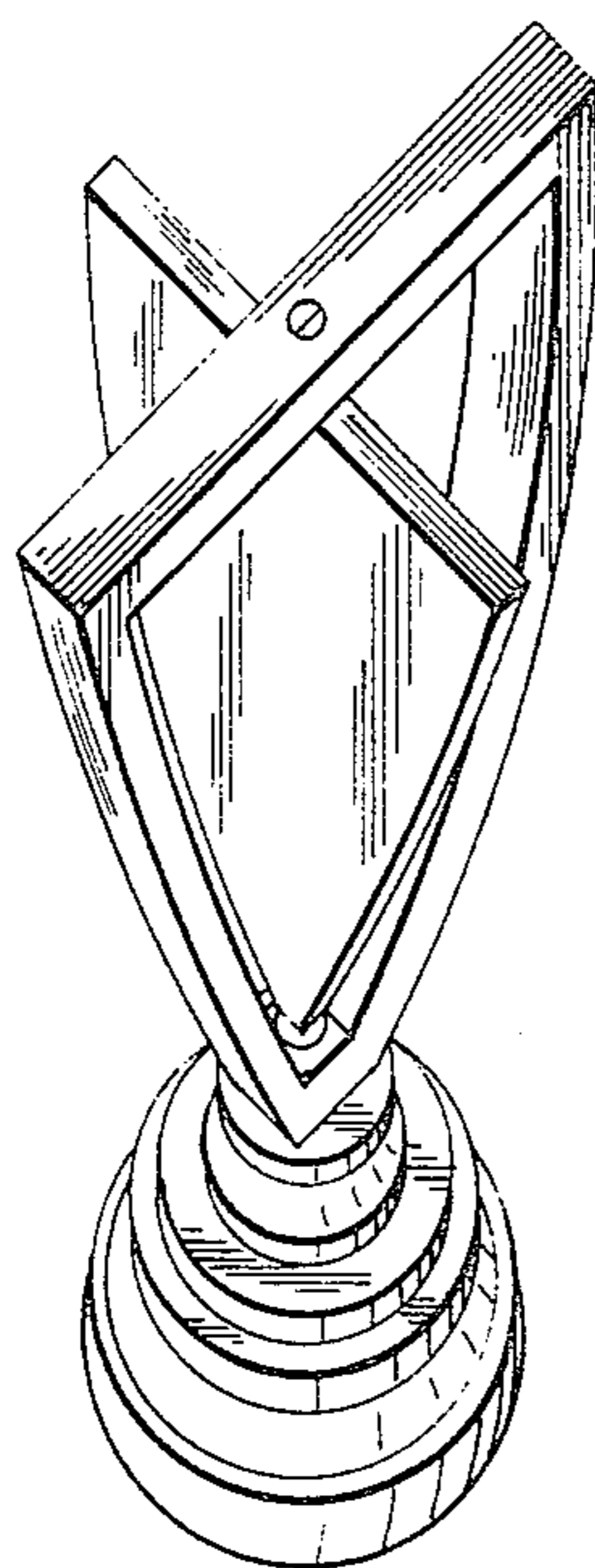

FIG. 36

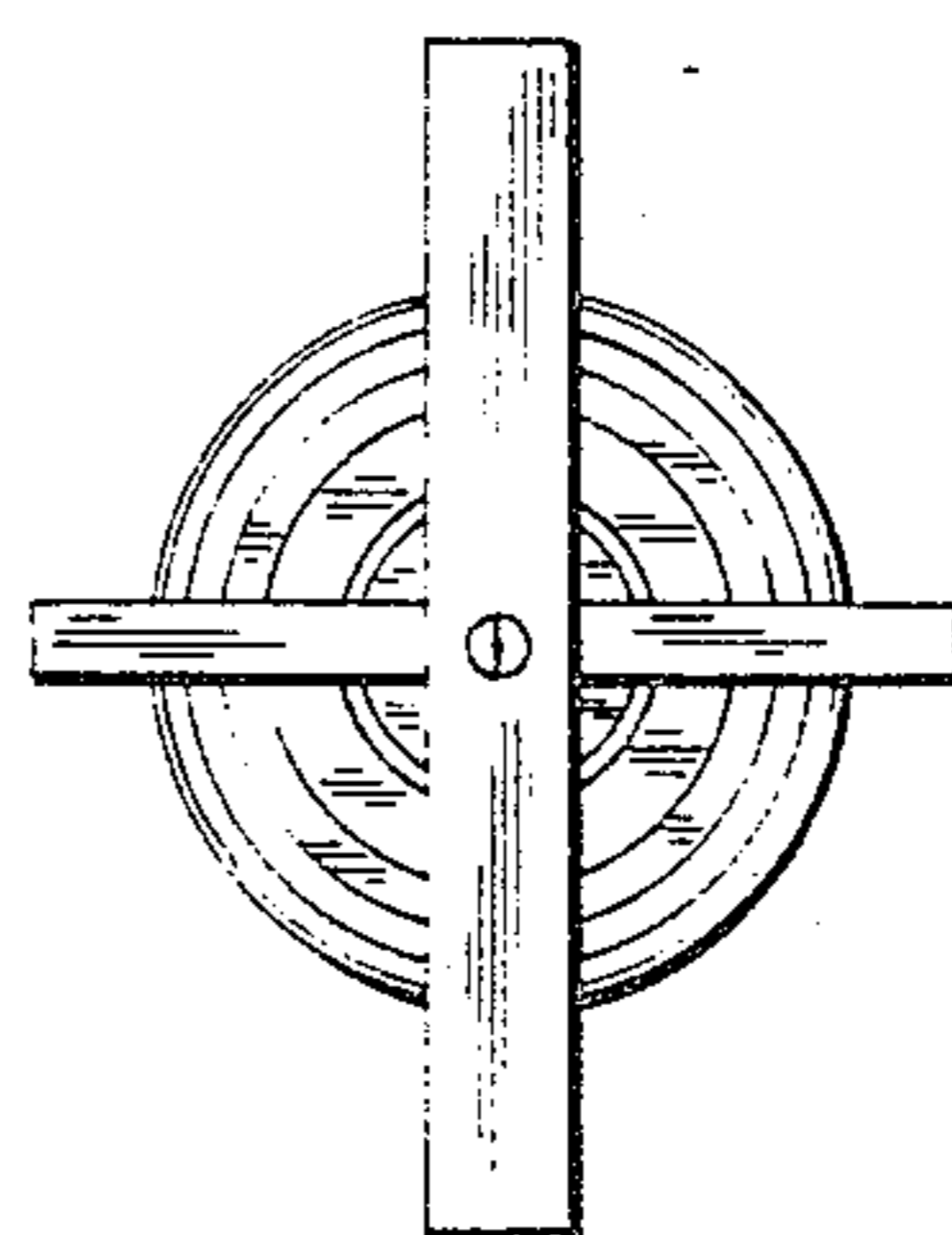

FIG.37

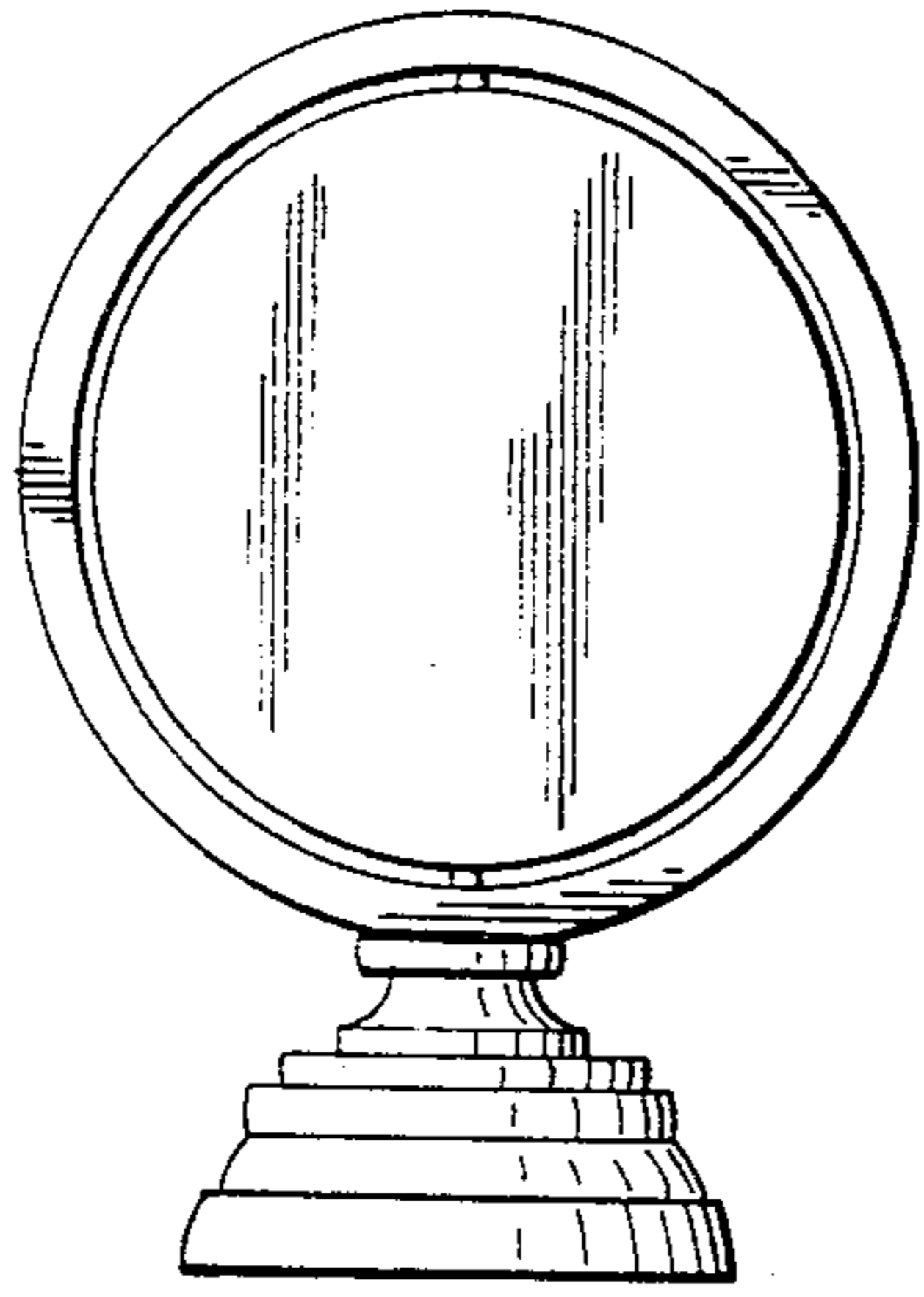

FIG.38

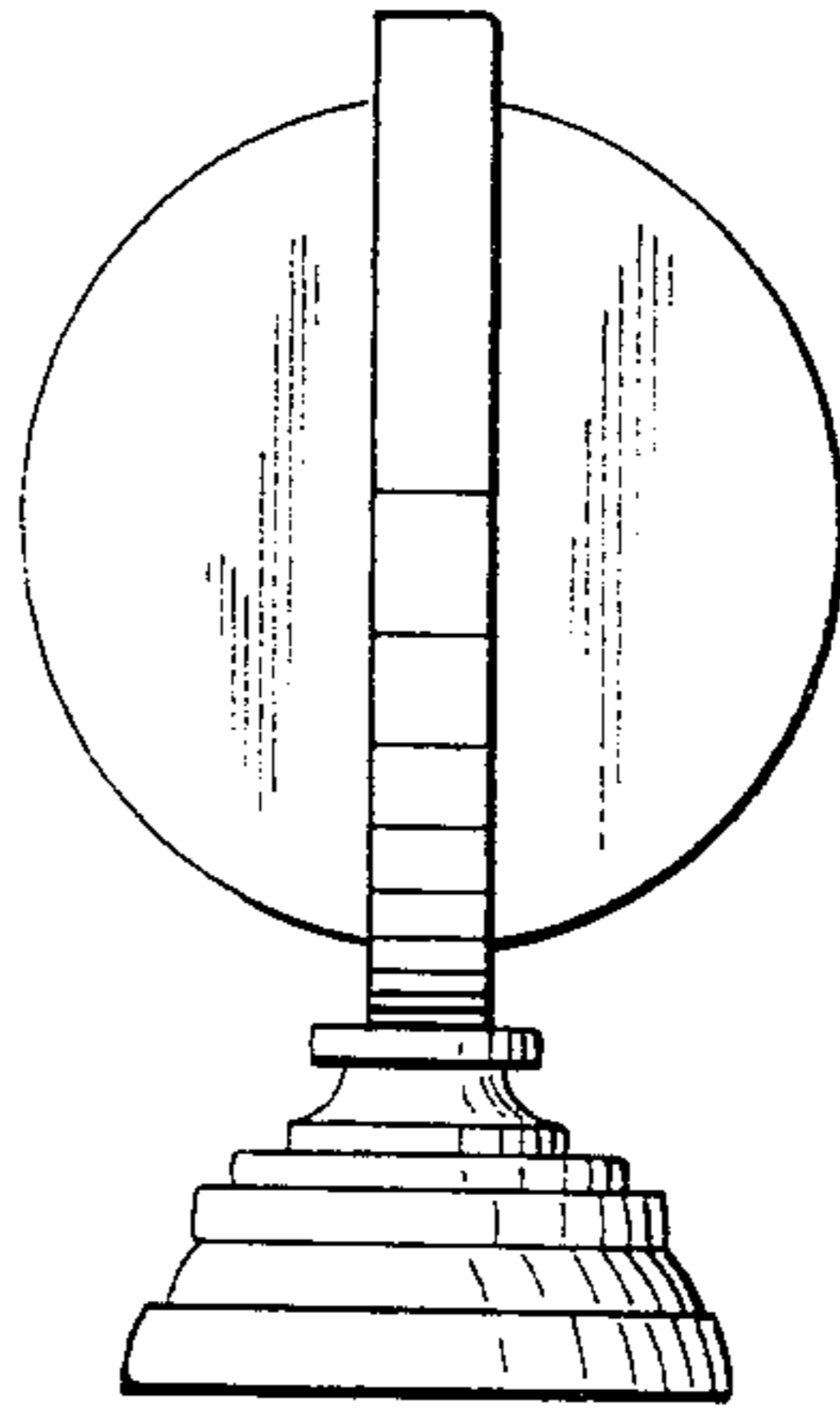

FIG.39

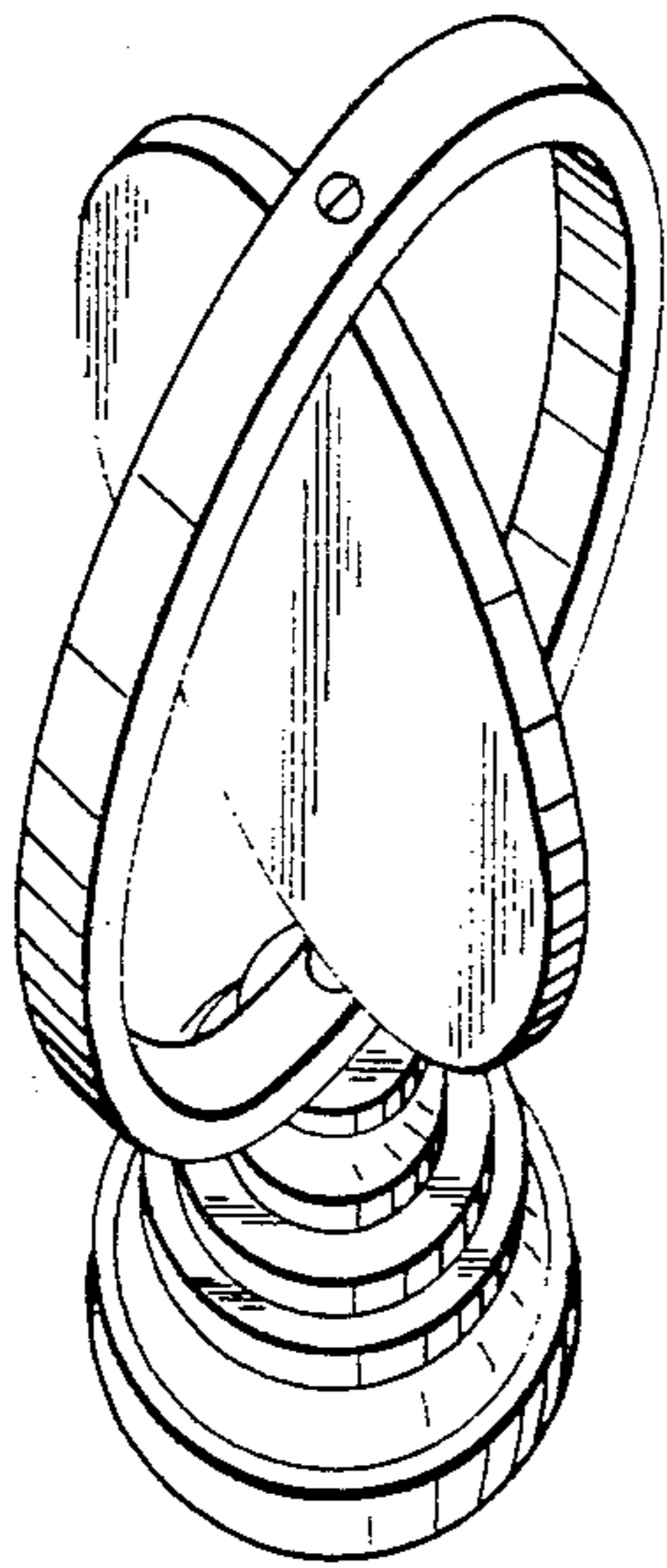

FIG.40

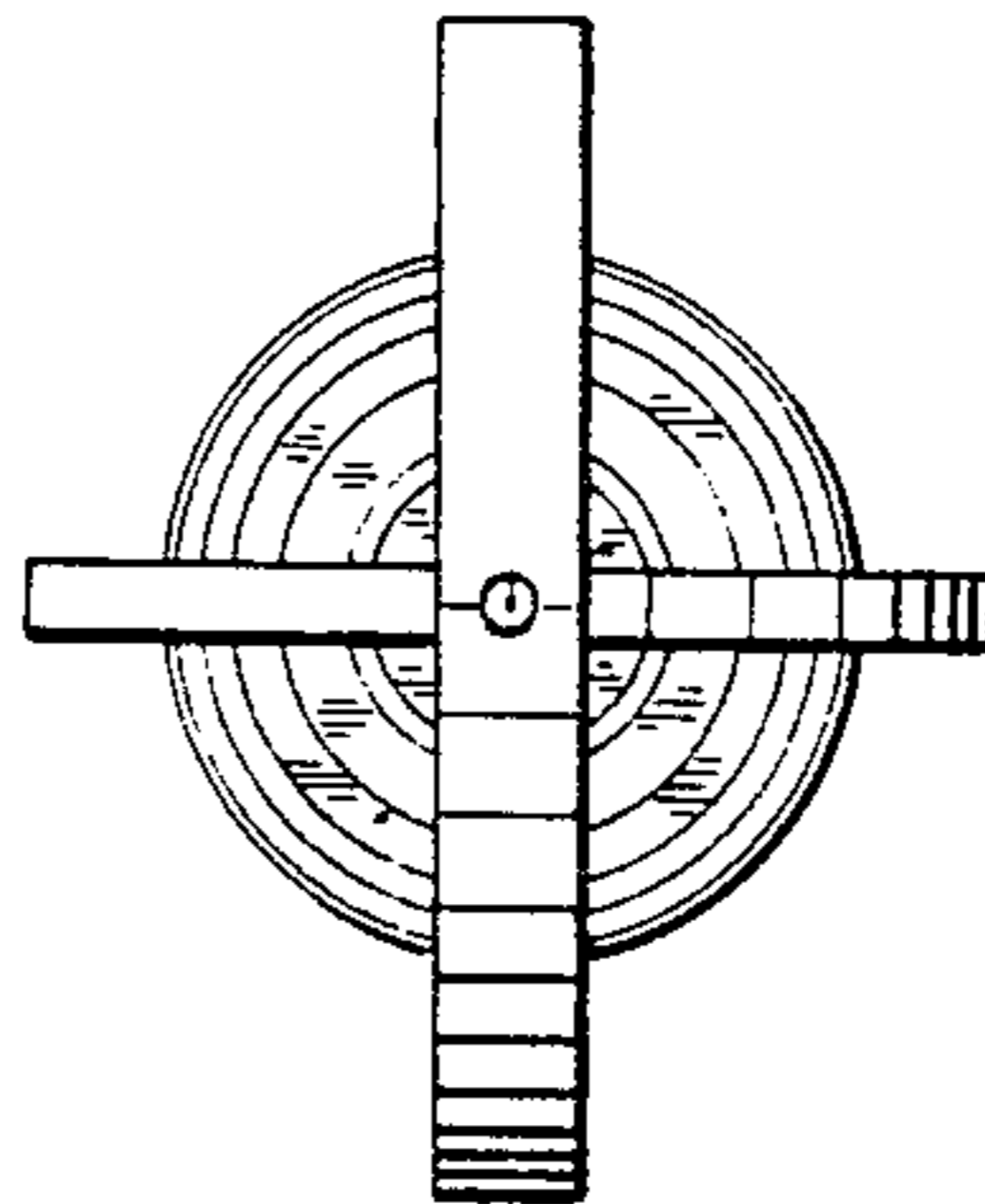

FIG. 41

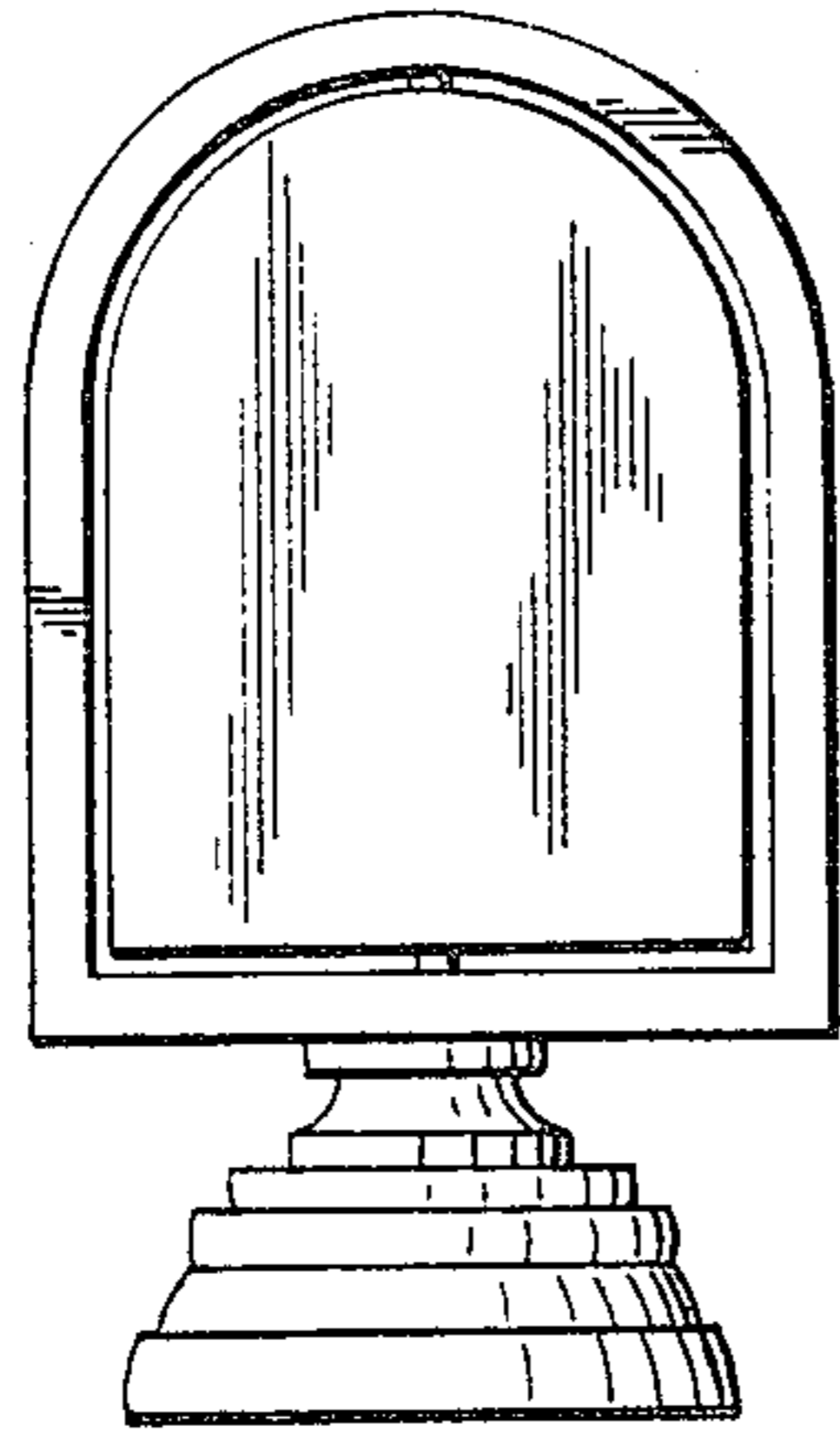

FIG. 42

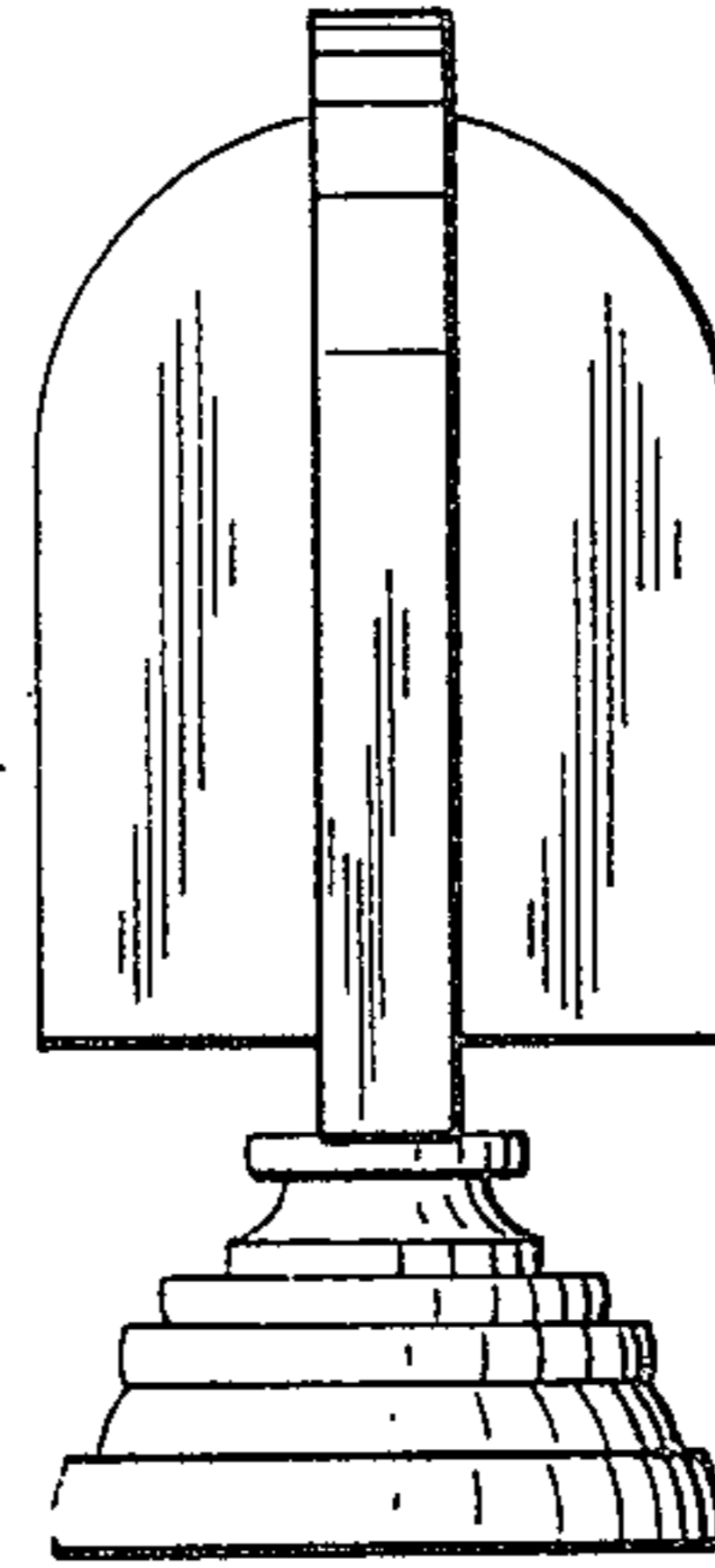

FIG. 43

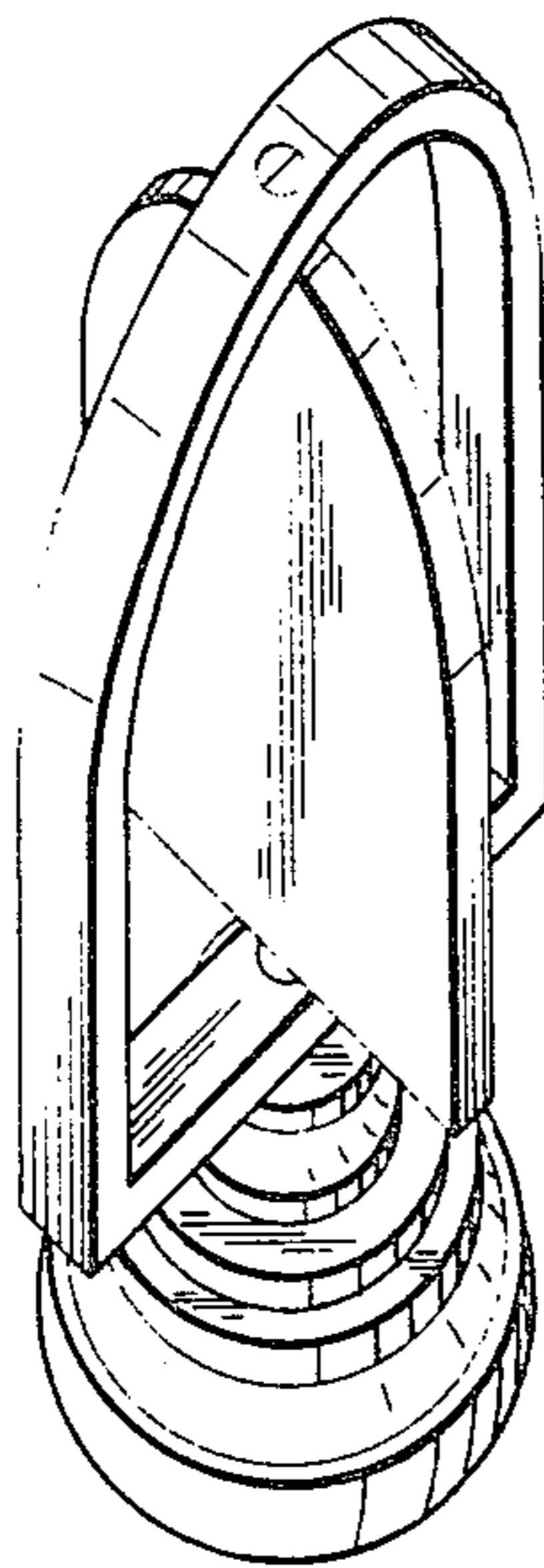

FIG. 44

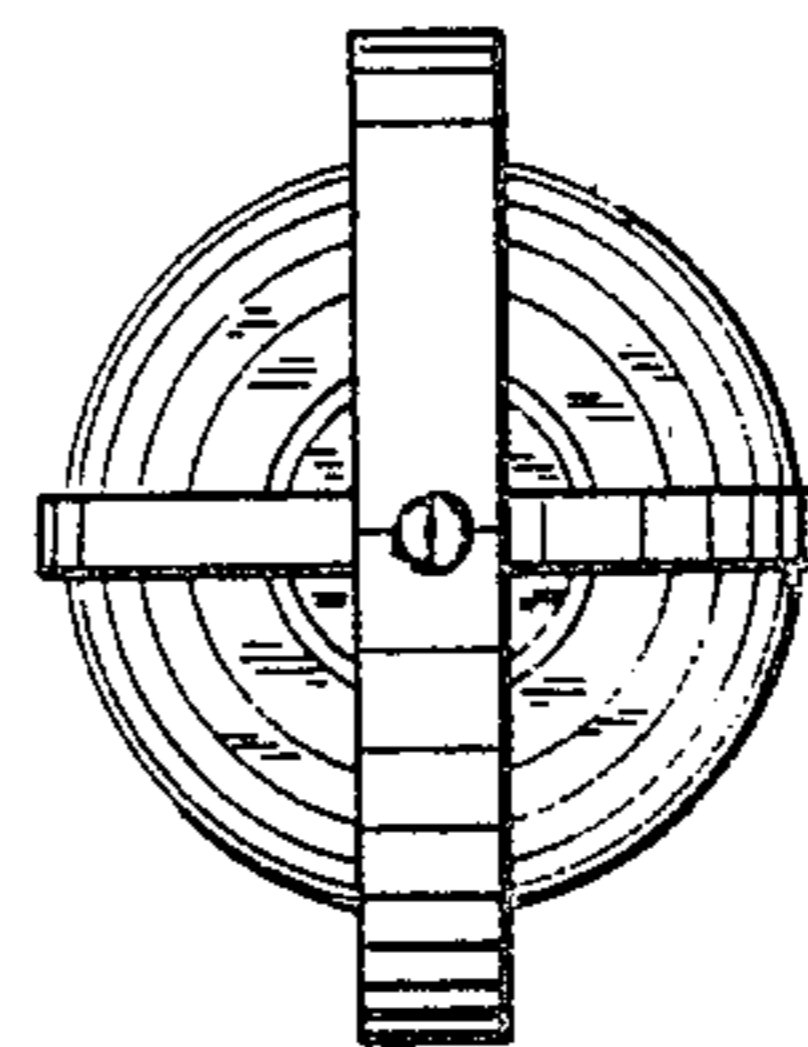

FIG.45

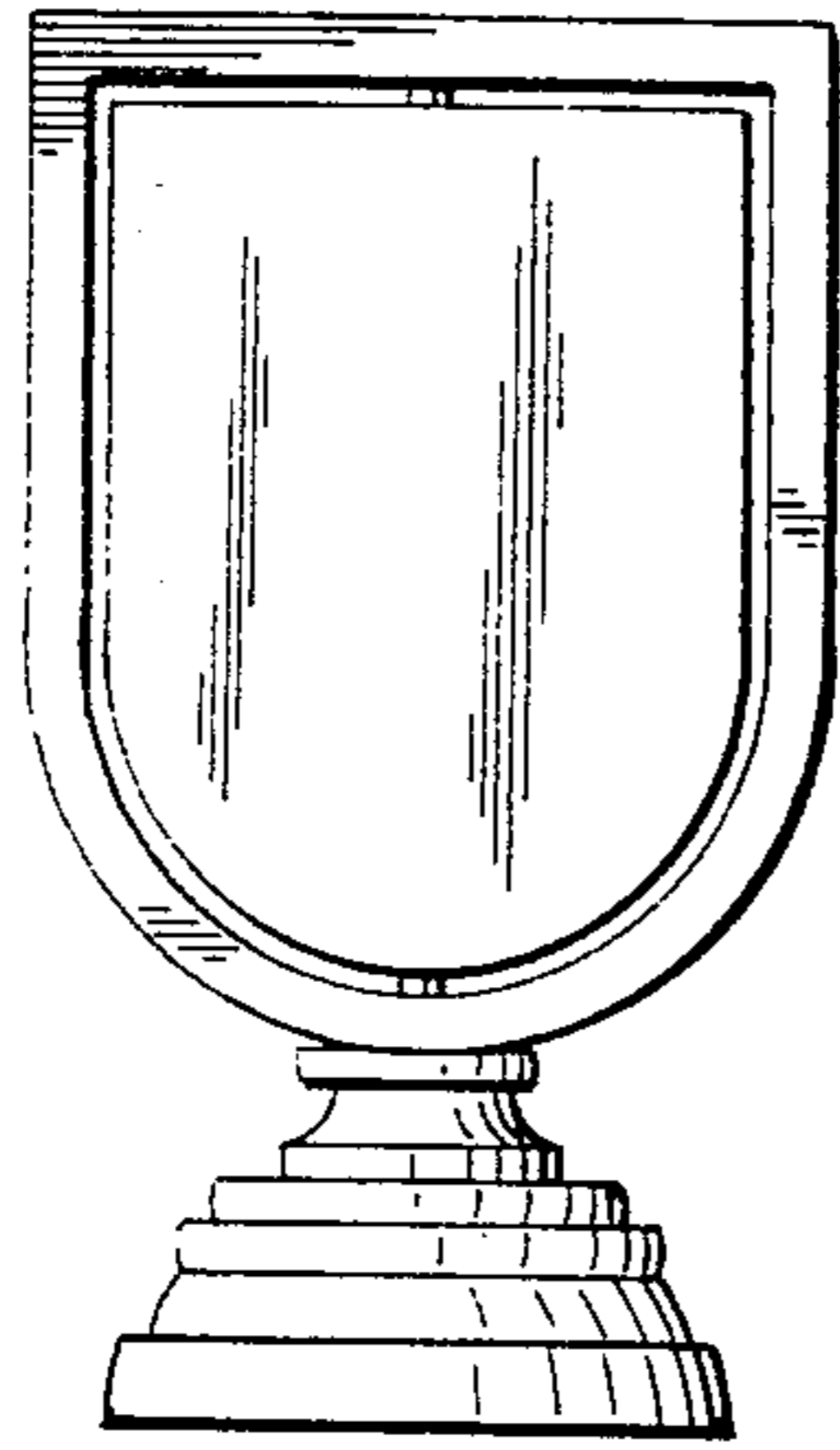

FIG.46

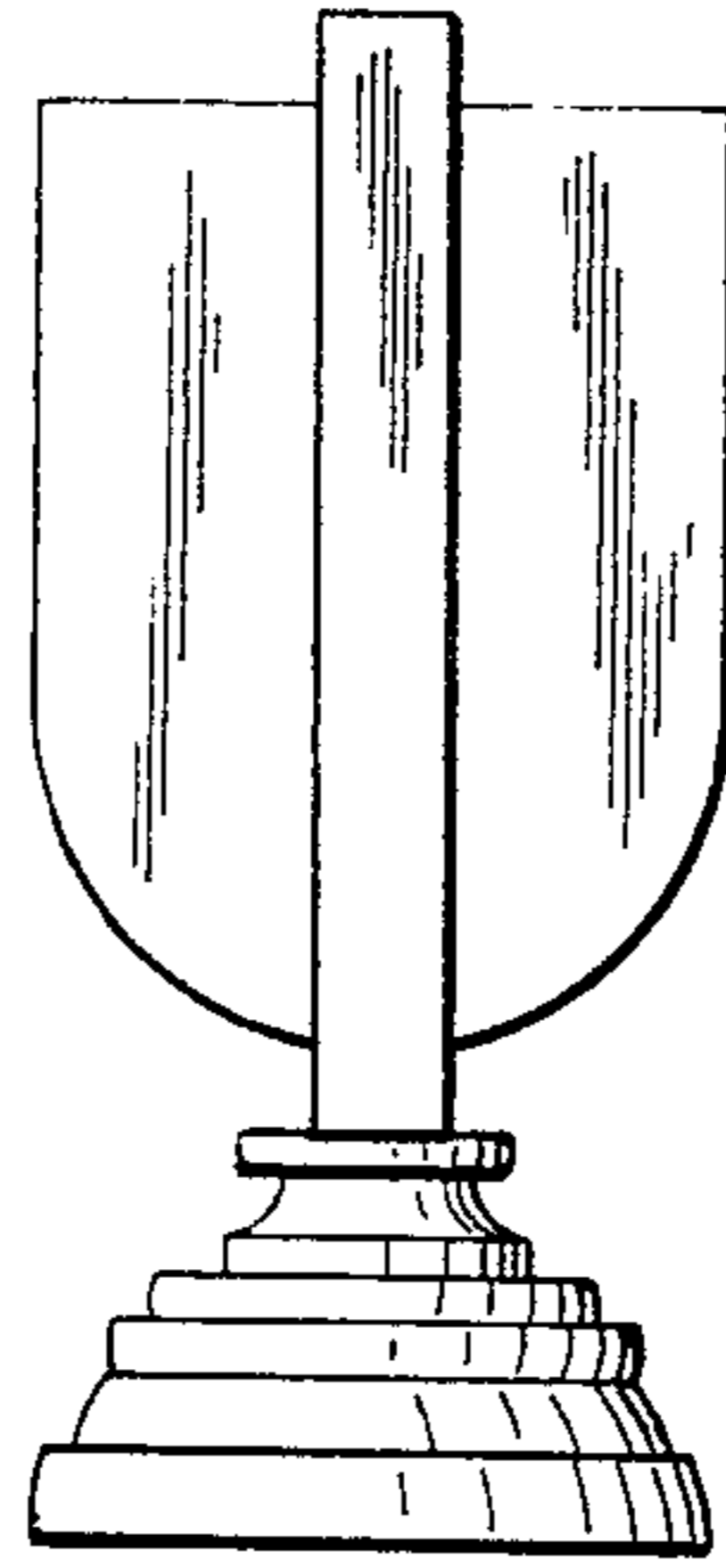

FIG.47

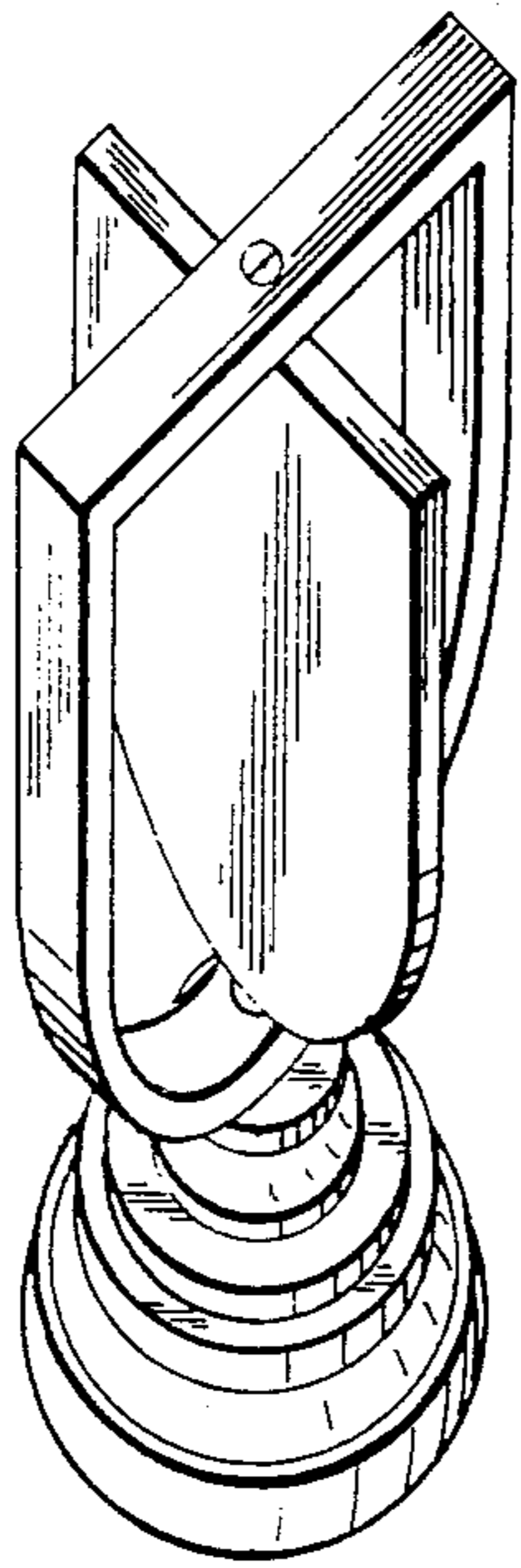

FIG.48

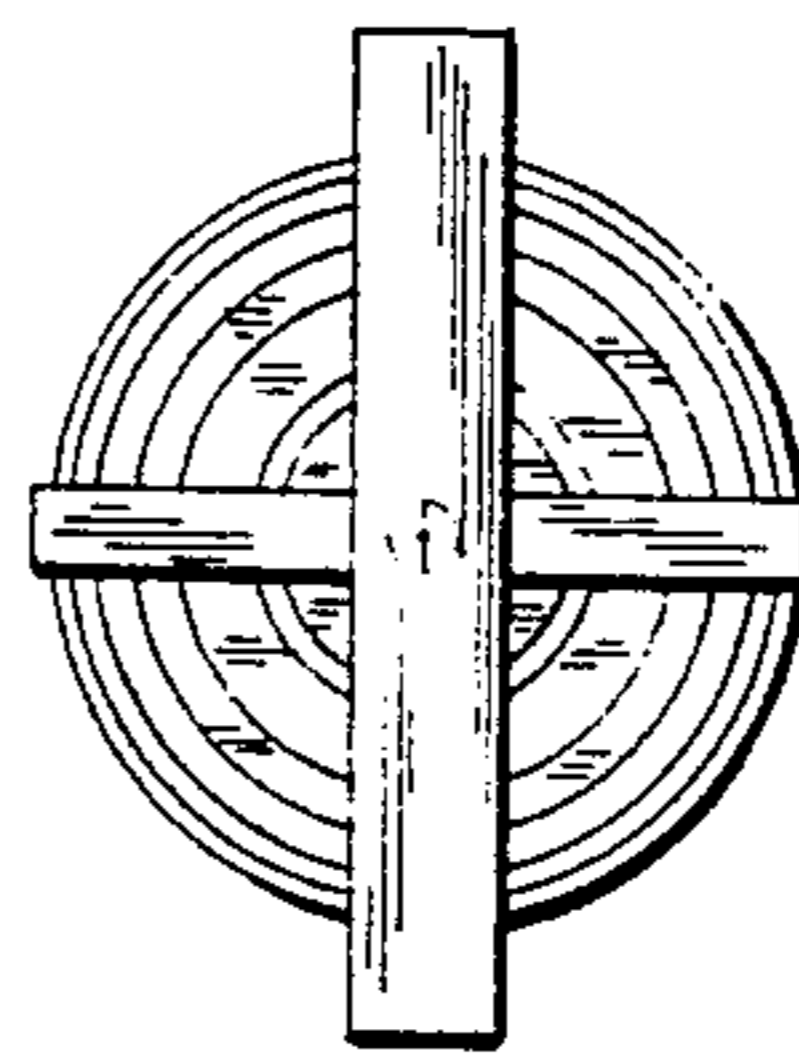

FIG. 49

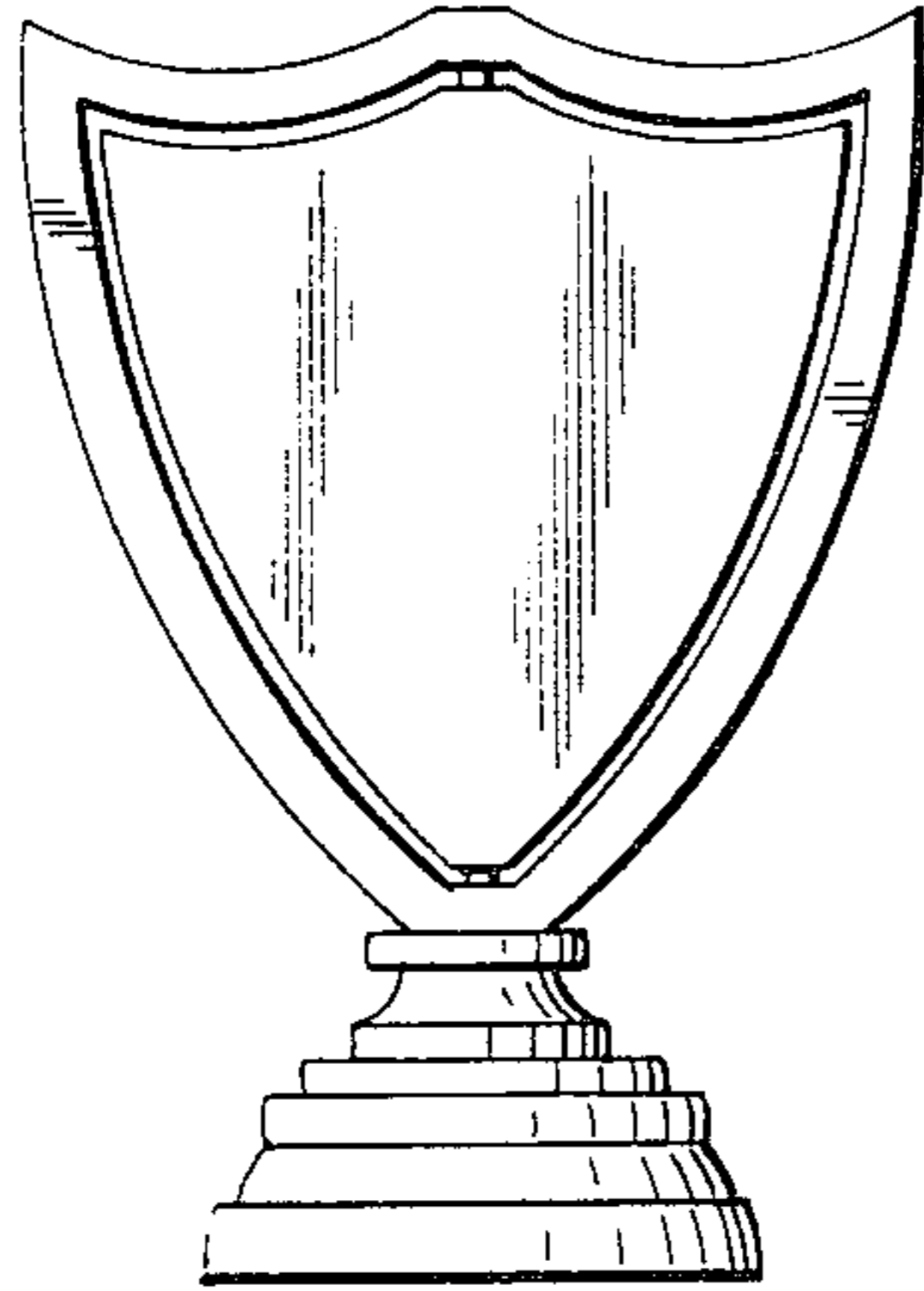

FIG. 50

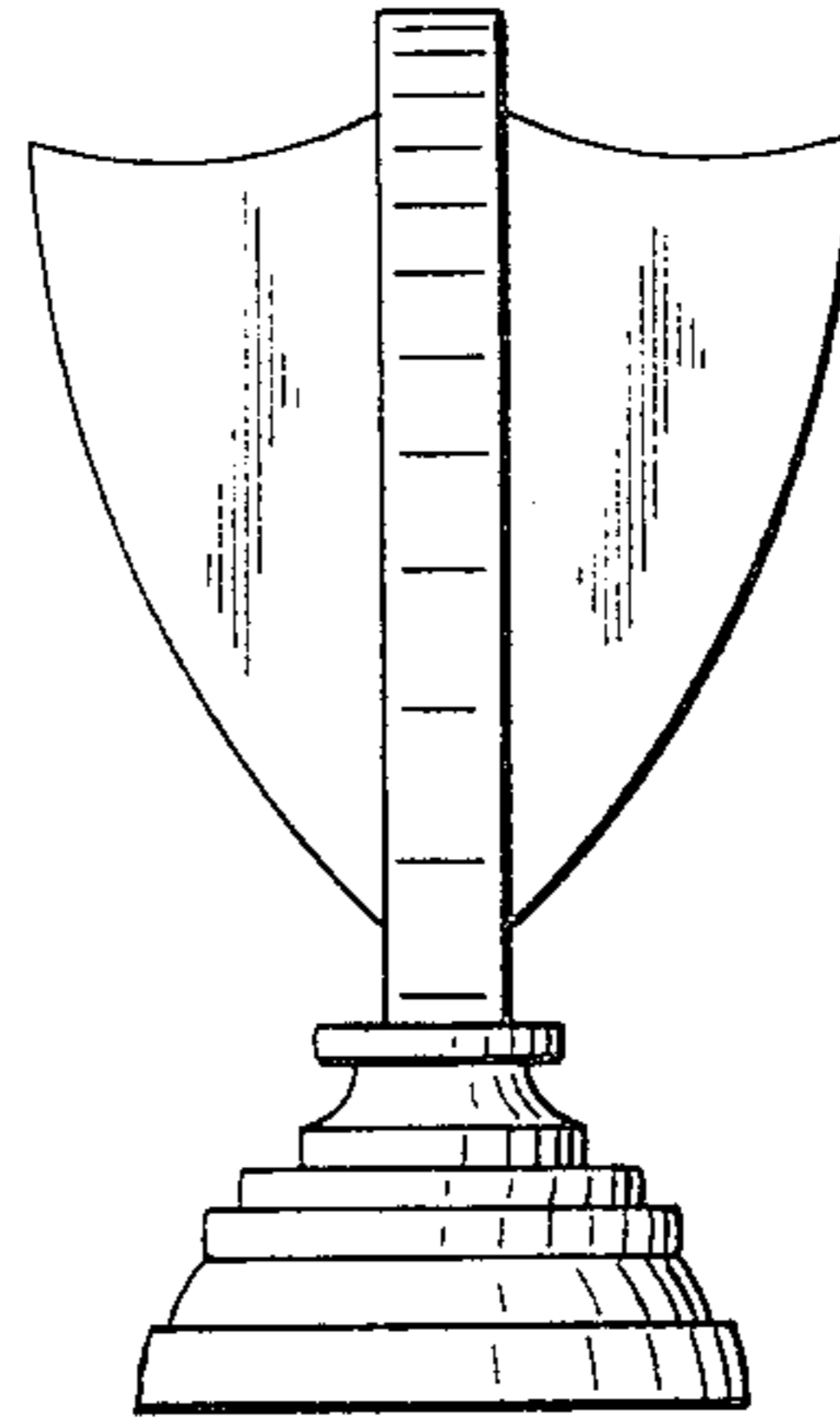

FIG. 51

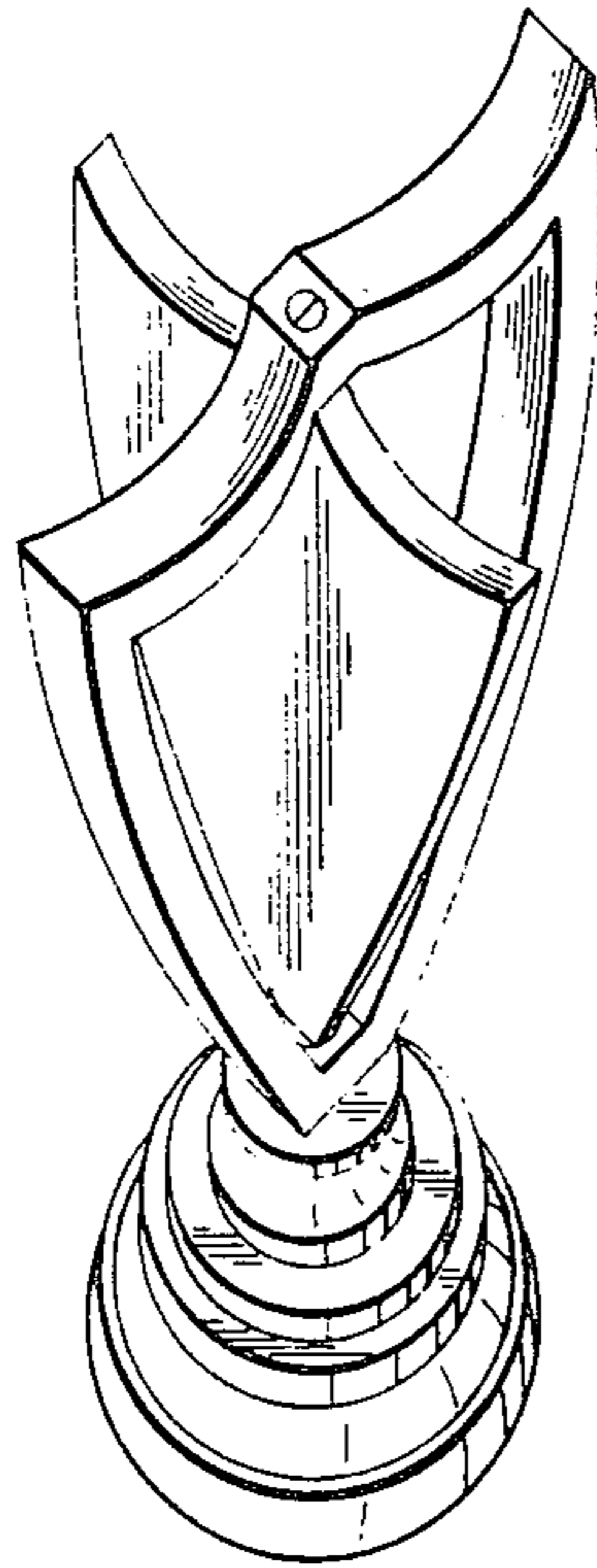

FIG. 52

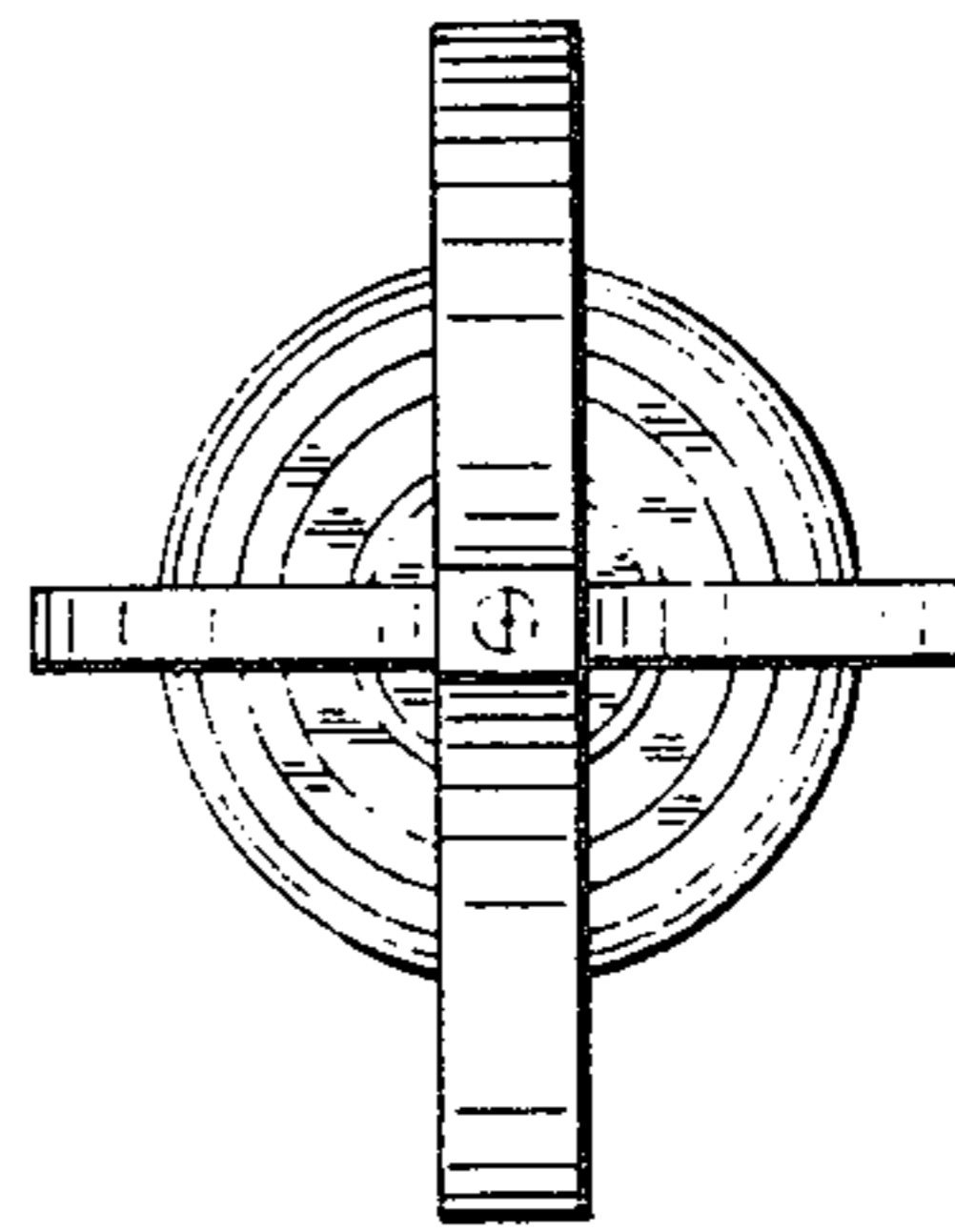

FIG. 53

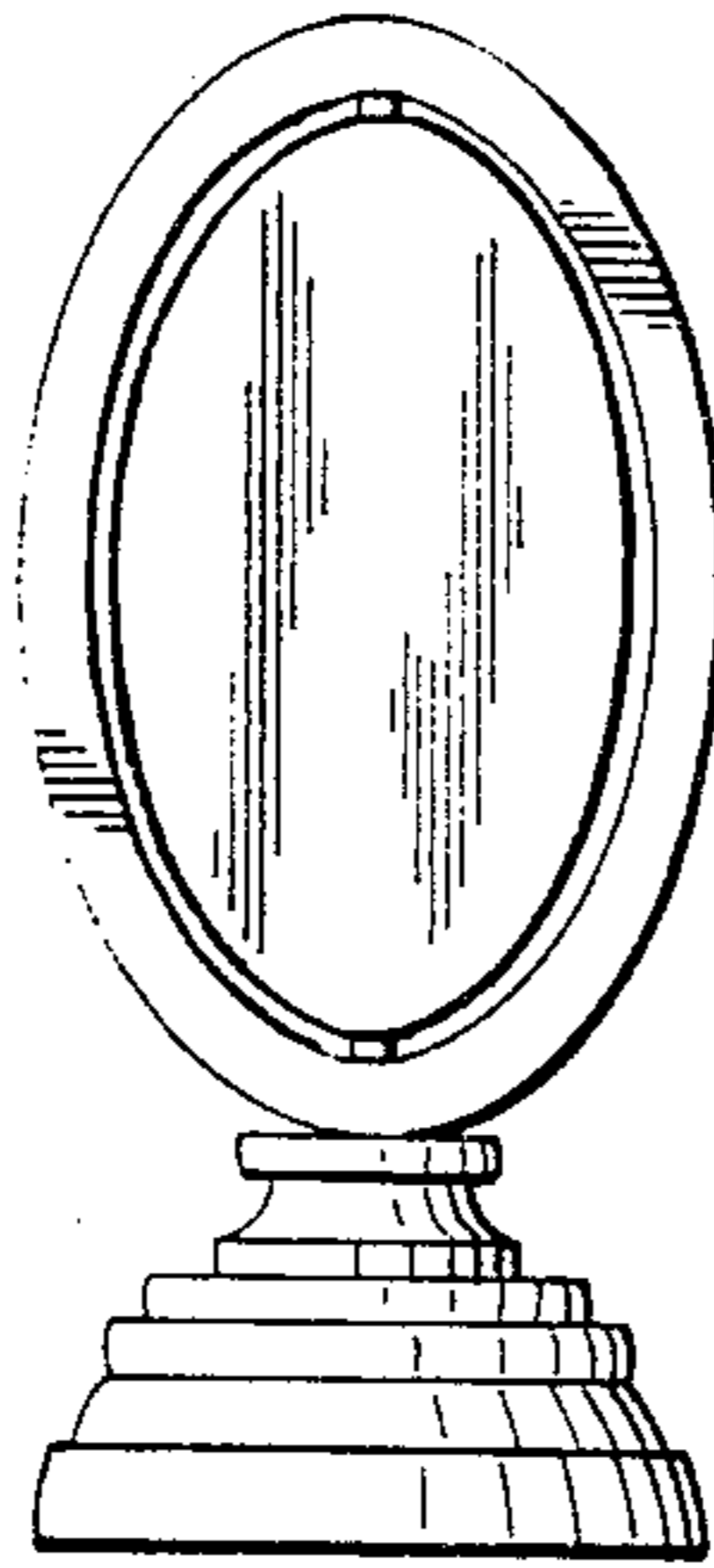

FIG. 54

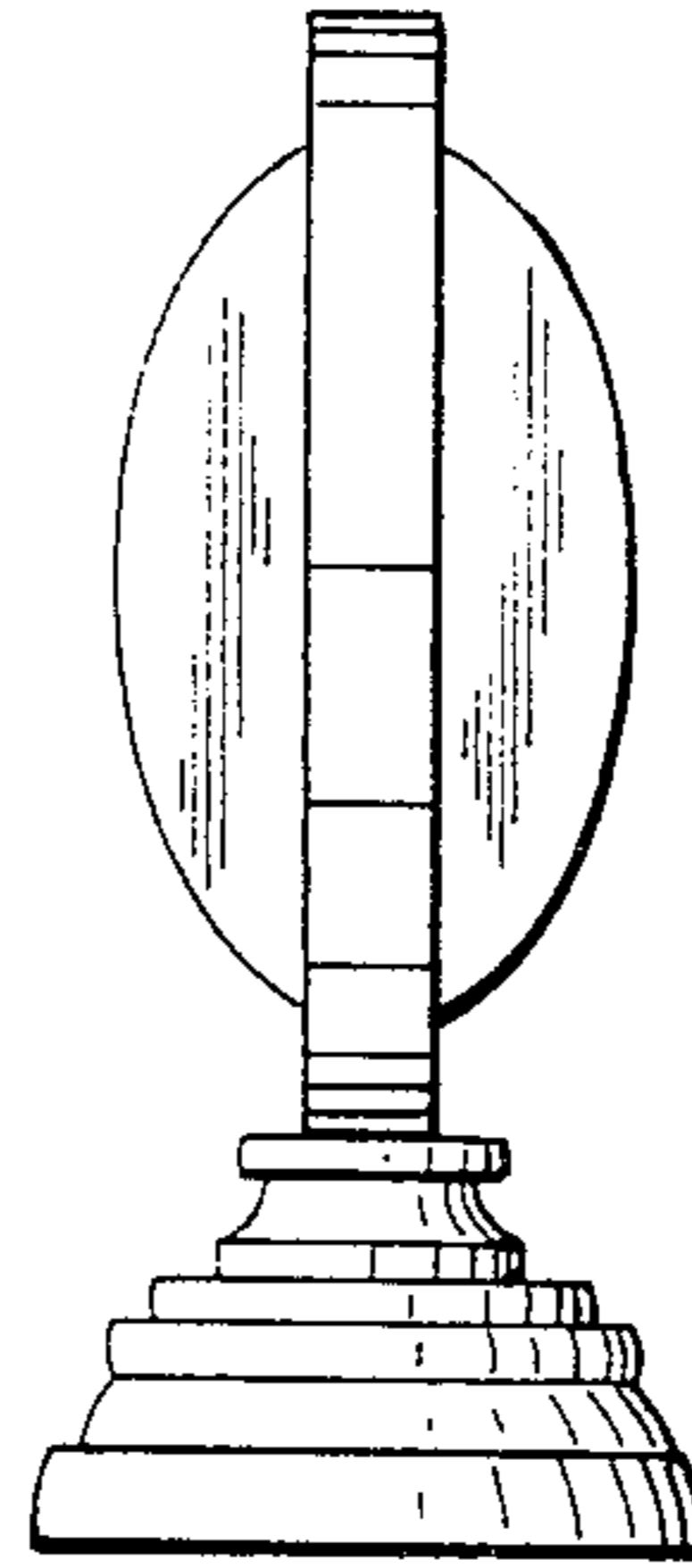

FIG. 55

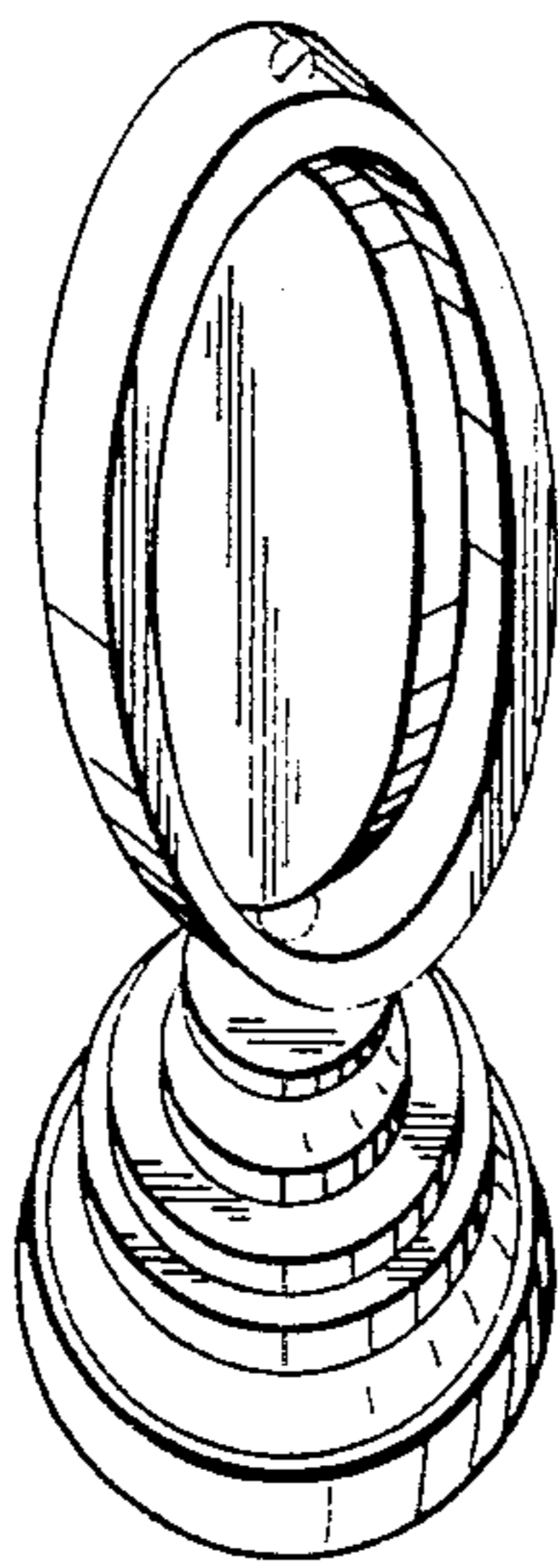

FIG. 56

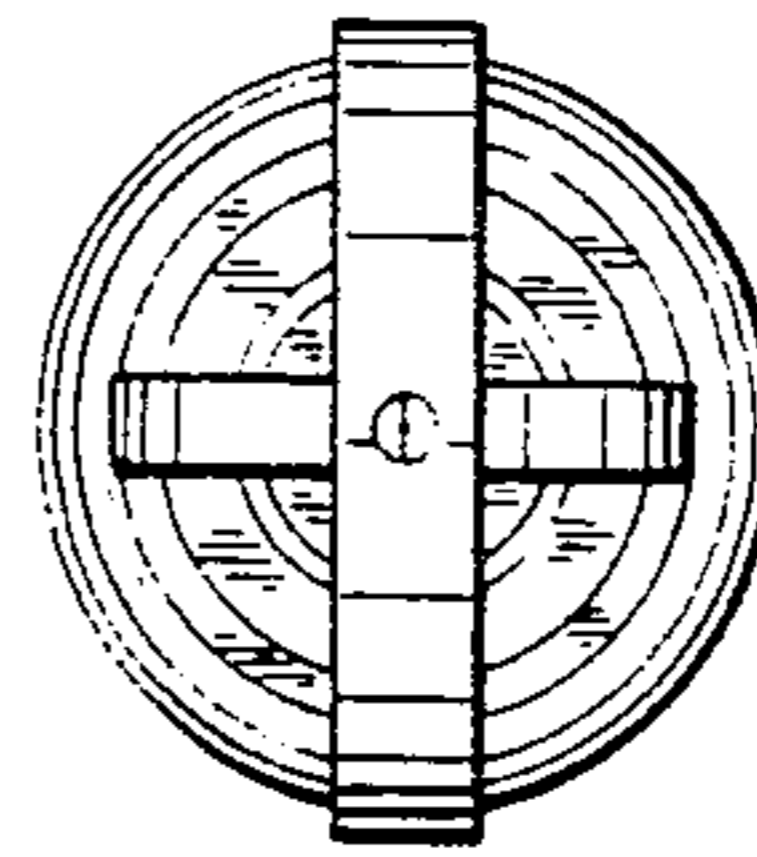

FIG. 57

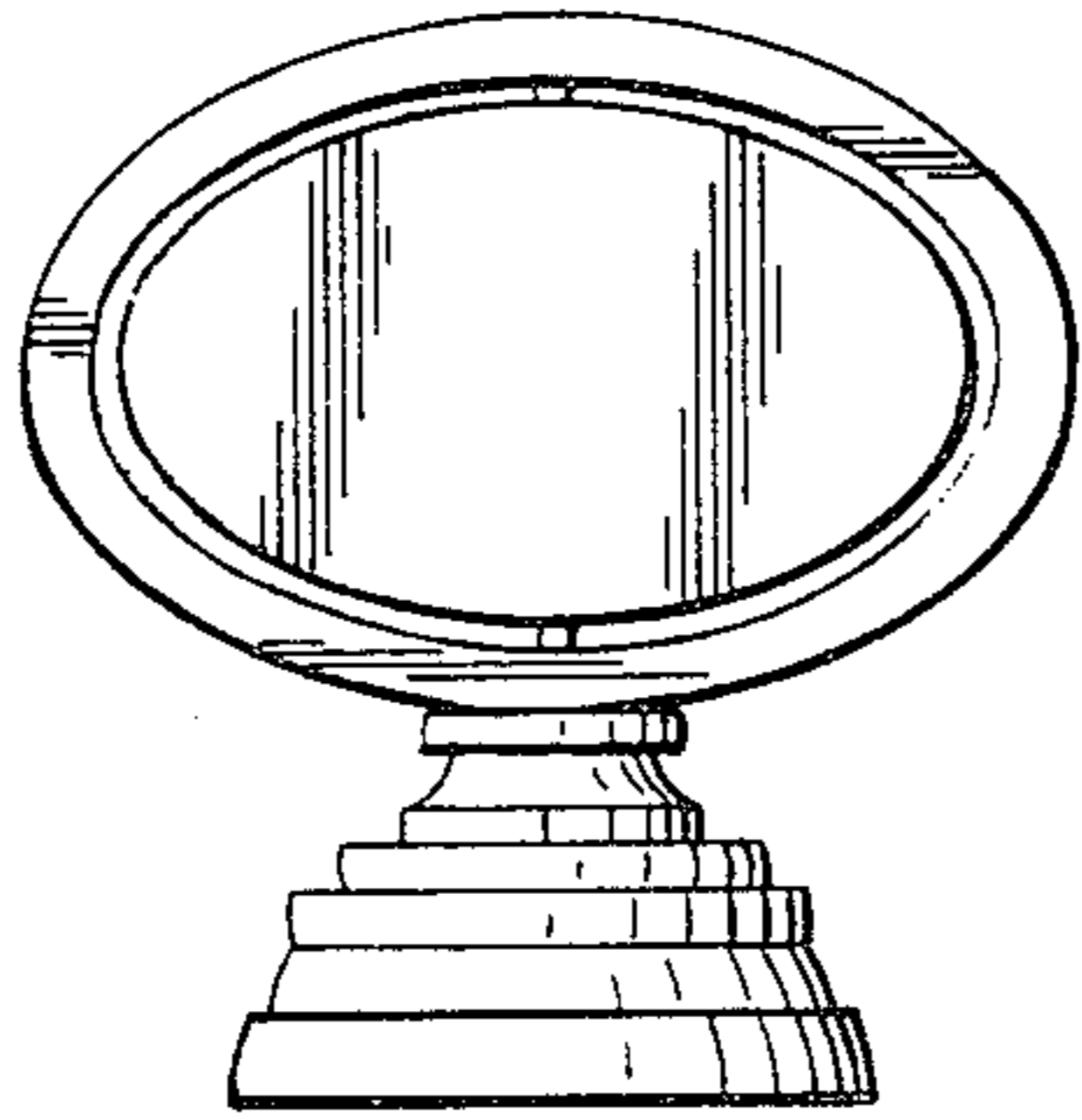

FIG. 58

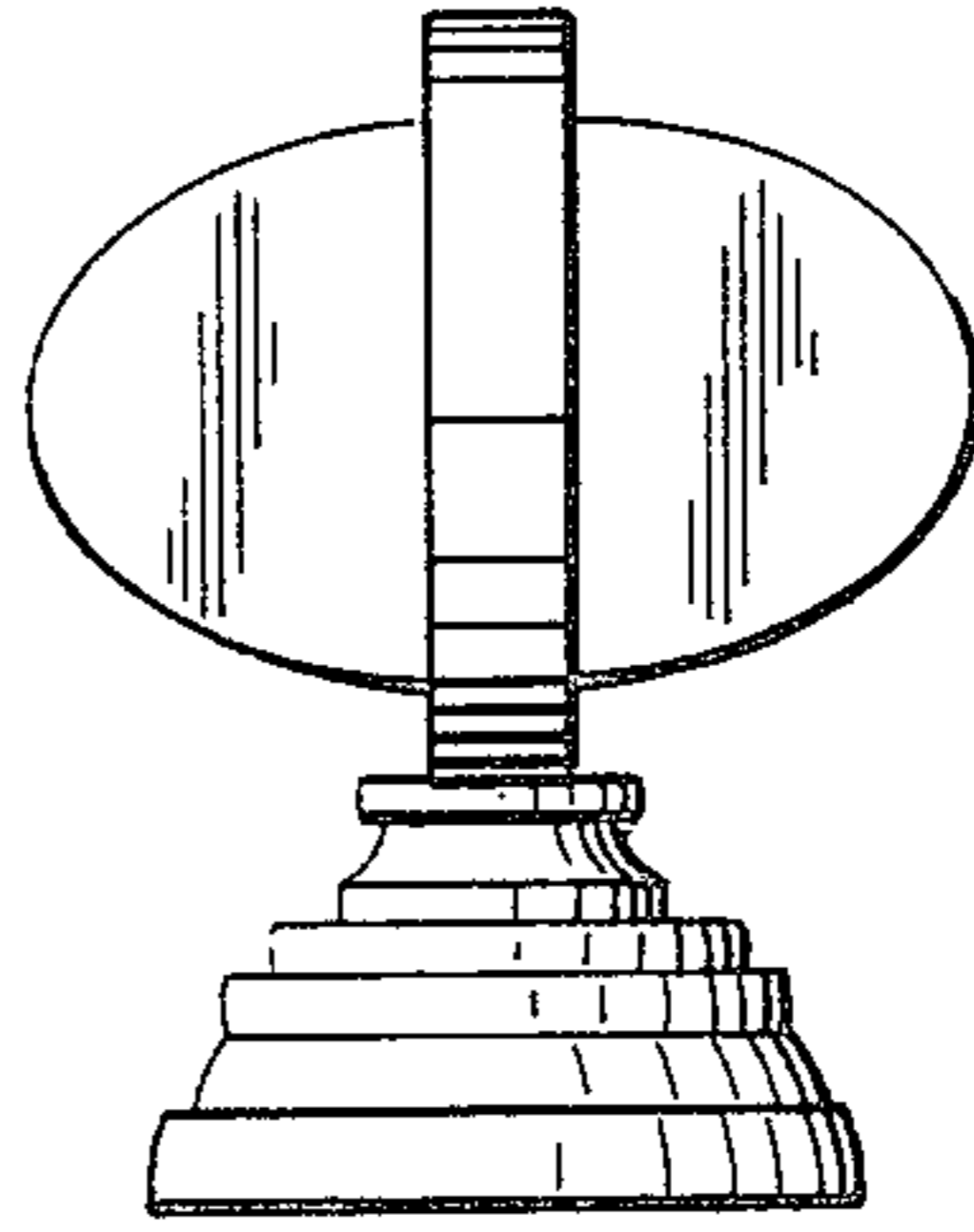

FIG. 59

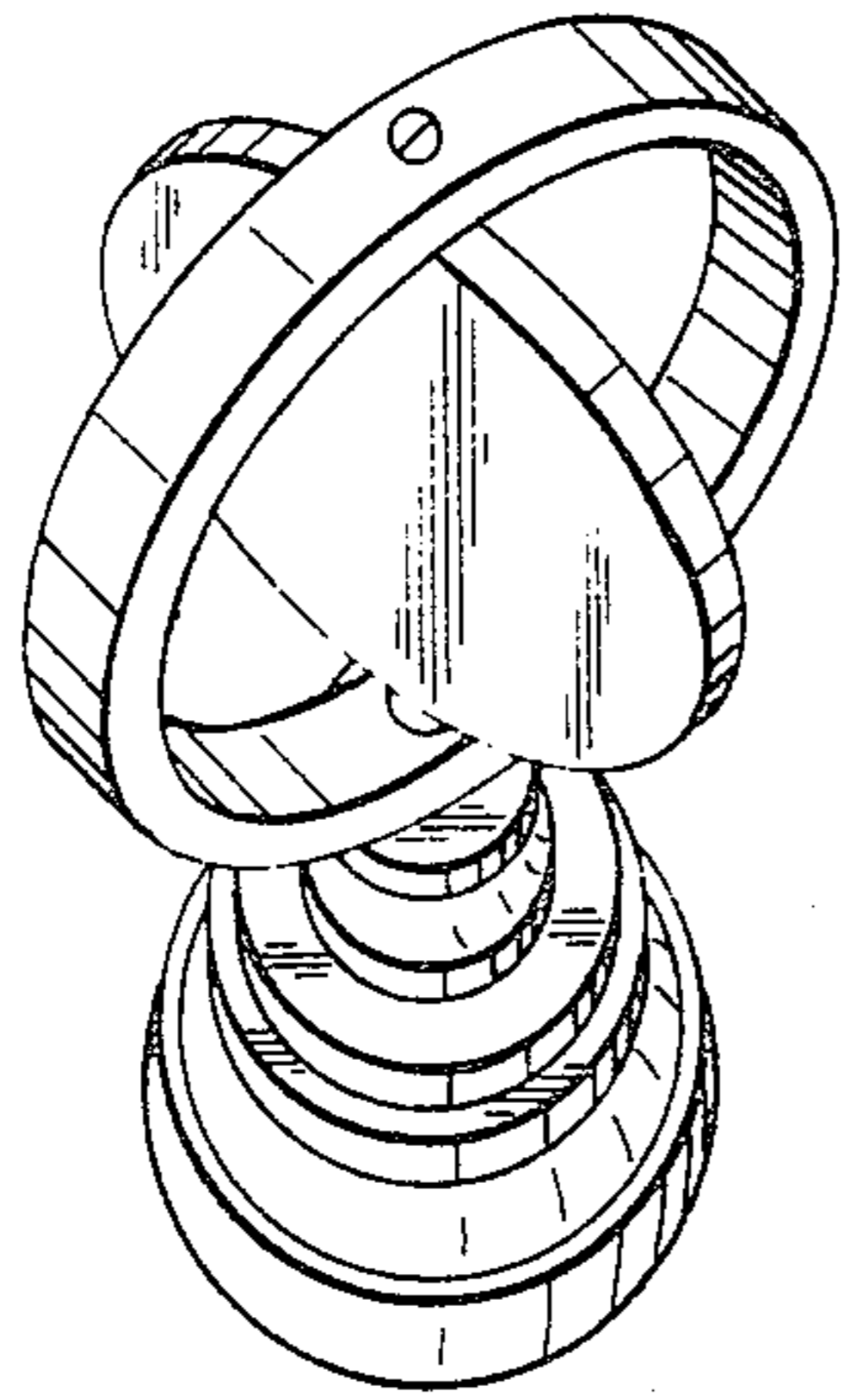

FIG. 60

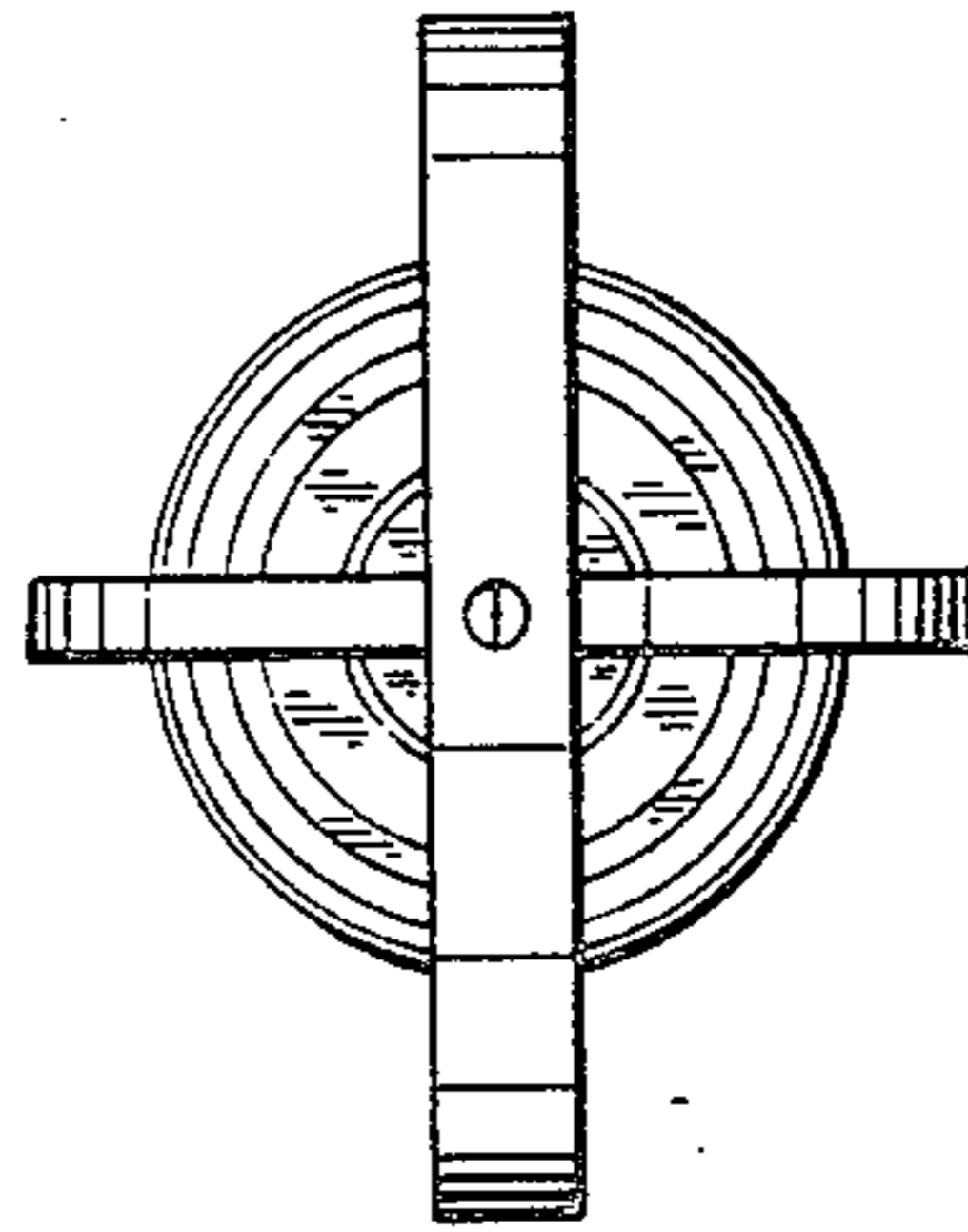

FIG. 61

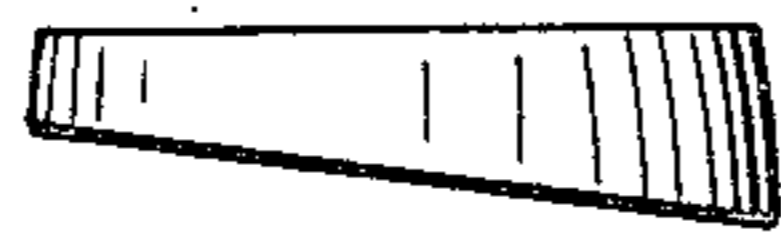
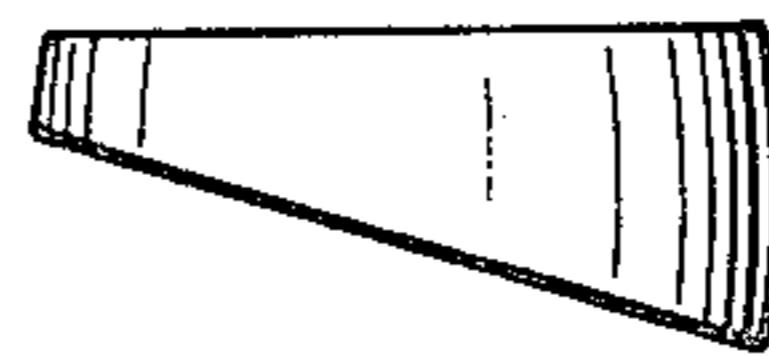

FIG. 62





UNITED STATES PATENT AND TRADEMARK OFFICE  
**CERTIFICATE OF CORRECTION**

PATENT NO. : Des. 280,807  
DATED : October 1, 1985  
INVENTOR(S) : Elmer KAISER

Page 1 of 4

It is certified that error appears in the above-identified patent and that said Letters Patent is hereby corrected as shown below:

On page 1 of the patent, in the "Description",  
insert: (1) between the description of "Fig. 11" and  
"Fig. 30", the following:

-- Fig. 12 is a top plan view thereof;

Fig. 13 is a front elevational view of a fourth  
embodiment of a combined vehicle ornament and  
advertising device;

Fig. 14 is a side elevational view thereof, shown  
with the central panel rotated;

Fig. 15 is a perspective view thereof;

Fig. 16 is a top plan view thereof;

Fig. 17 is a front elevational view of a fifth  
embodiment of a combined vehicle ornament and  
advertising device;

Fig. 18 is a side elevational view thereof, shown  
with the central panel rotated;

Fig. 19 is a perspective view thereof;

Fig. 20 is a top plan view thereof;

UNITED STATES PATENT AND TRADEMARK OFFICE  
CERTIFICATE OF CORRECTION

PATENT NO. : Des. 280,807  
DATED : October 1, 1985  
INVENTOR(S) : Elmer KAISER

Page 2 of 4

It is certified that error appears in the above—identified patent and that said Letters Patent is hereby corrected as shown below:

Fig. 21 is a front elevational view of a sixth embodiment of a combined vehicle ornament and advertising device;

Fig. 22 is a side elevational view thereof, shown with the central panel rotated;

Fig. 23 is a perspective view thereof;

Fig. 24 is a top plan view thereof;

Fig. 25 is a front elevational view of a seventh embodiment of a combined vehicle ornament and advertising device;

Fig. 26 is a side elevational view thereof, shown with the central panel rotated;

Fig. 27 is a perspective view thereof;

Fig. 28 is a top plan view thereof;

Fig. 29 is a front elevational view of an eighth embodiment of a combined vehicle ornament advertising device;--

UNITED STATES PATENT AND TRADEMARK OFFICE  
CERTIFICATE OF CORRECTION

PATENT NO. : Des. 280,807  
DATED : October 1, 1985  
INVENTOR(S) : Elmer KAISER

Page 3 of 4

It is certified that error appears in the above—identified patent and that said Letters Patent is hereby corrected as shown below:

(2) after the description of "Fig. 50", insert the following:

-- Fig. 51 is a perspective view thereof;

Fig. 52 is a top plan view thereof;

Fig. 53 is a front elevational view of a fourteenth embodiment of a combined vehicle ornament and advertising device;

Fig. 54 is a side elevational view thereof, shown with the central panel rotated;

Fig. 55 is a perspective view thereof;

Fig. 56 is a top plan view thereof;

Fig. 57 is a front elevational view of a fifteenth embodiment of a combined vehicle ornament and advertising device;

Fig. 58 is a side elevational view thereof, shown with the central panel rotated;

Fig. 59 is a perspective view thereof;

UNITED STATES PATENT AND TRADEMARK OFFICE  
**CERTIFICATE OF CORRECTION**

PATENT NO. : Des. 280,807

Page 4 of 4

DATED : October 1, 1985

INVENTOR(S) : Elmer KAISER

It is certified that error appears in the above-identified patent and that said Letters Patent is hereby corrected as shown below:

Fig. 60 is a top plan view thereof;

Fig. 61 is a side elevational view of an alternate base;

Fig. 62 is a side elevational view of a third alternate base.--

**Signed and Sealed this  
Seventh Day of October, 1986**

[SEAL]

*Attest:*

DONALD J. QUIGG

*Attesting Officer*

*Commissioner of Patents and Trademarks*