

[54] **TOY MOTORCYCLE**

[75] **Inventor: Erling T. Dideriksen, Billund, Denmark**

[73] **Assignee: Interlego A.G., Switzerland**

[**] **Term: 14 Years**

[21] **Appl. No.: 448,779**

[22] **Filed: Dec. 10, 1982**

[30] **Foreign Application Priority Data**

Nov. 17, 1982 [DK] Denmark 1087/82

[52] **U.S. Cl. D21/135**

[58] **Field of Search D12/110; D21/76, 78, D21/79, 80, 81, 128, 135, 137; 446/440**

[56] **References Cited**

PUBLICATIONS

Stellar Mini-Bike Flier, 3-1970, front cover, Mini-Bike.

Sears Summer Catalog, 1959, p. 181, Motor Scooter at top left corner of page.
Motor Magazine, 6-1959, p. 166, Scooter at top of page.
Stile Industria, 2-1962, p. 22, Scooter at bottom of page.

Primary Examiner—Charles A. Rademaker
Attorney, Agent, or Firm—Kane, Dalsimer, Kane, Sullivan and Kurucz

[57] **CLAIM**

The ornamental design for toy motorcycle, as shown and described.

DESCRIPTION

FIG. 1 is a perspective view of a toy motorcycle showing my new design;
FIG. 2 is a bottom plan view thereof;
FIG. 3 is a front elevational view thereof;
FIG. 4 is a side elevational view thereof, the side opposite being substantially a mirror image;
FIG. 5 is a top plan thereof; and,
FIG. 6 is a rear elevational view thereof.

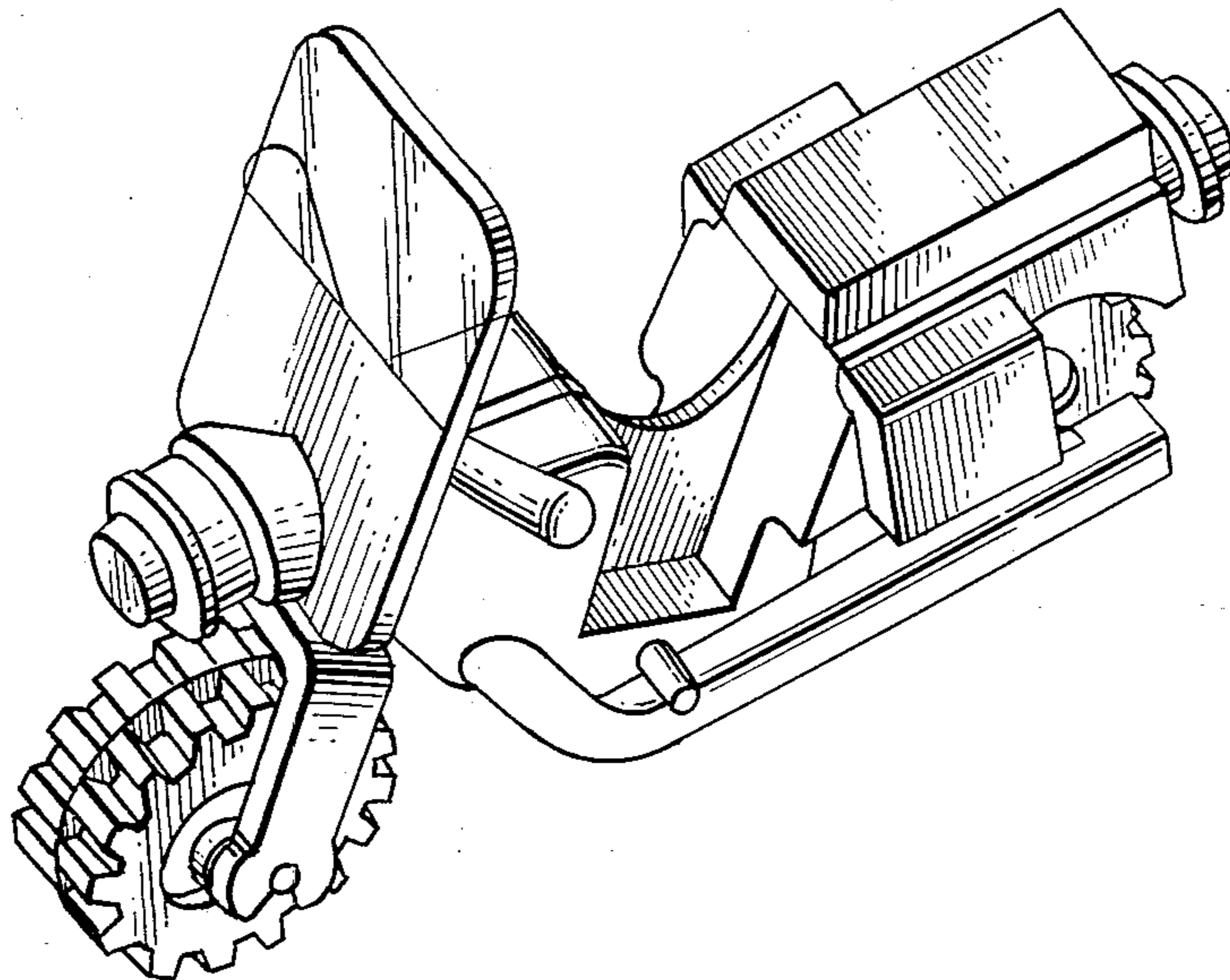

FIG. 1.

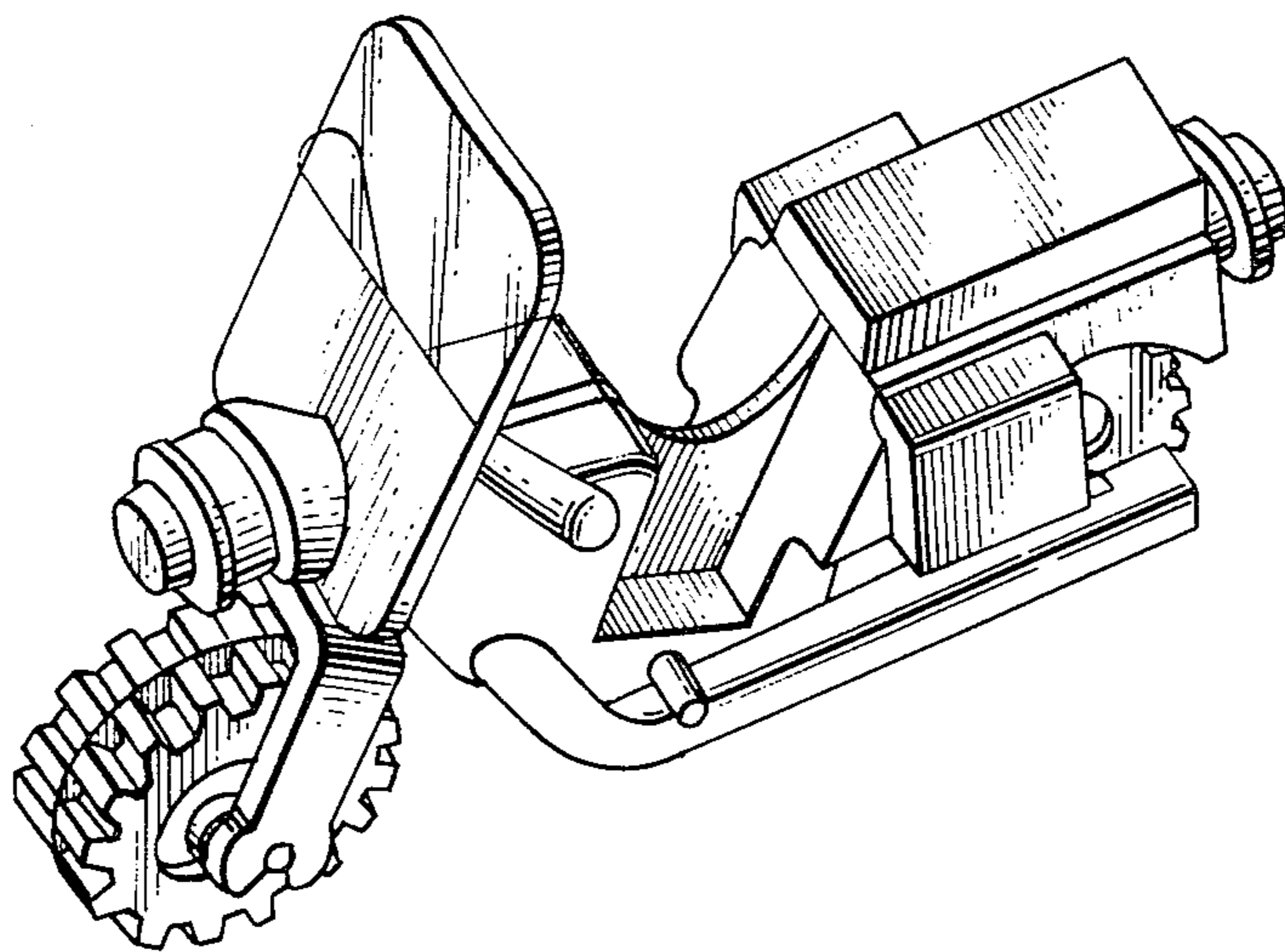

FIG. 2.

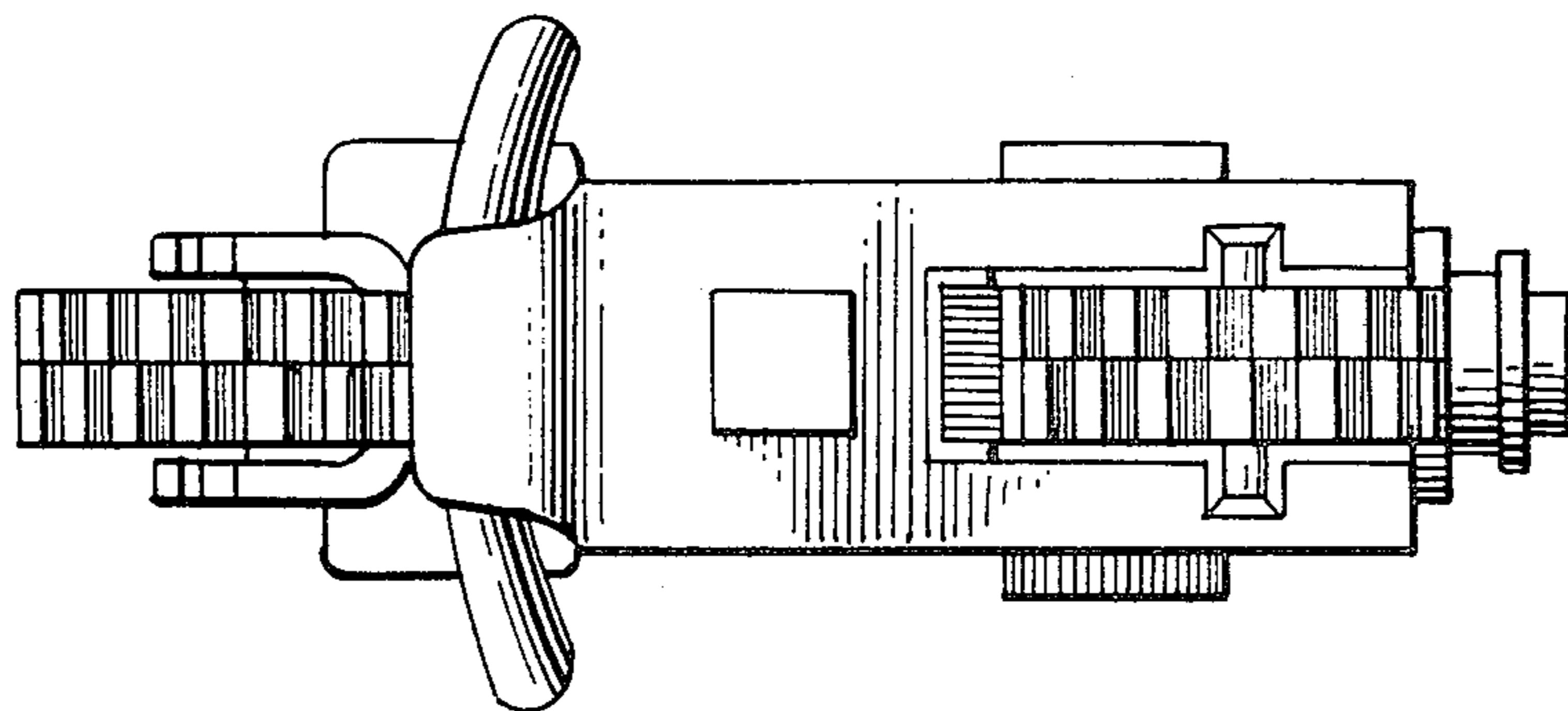

FIG. 3.

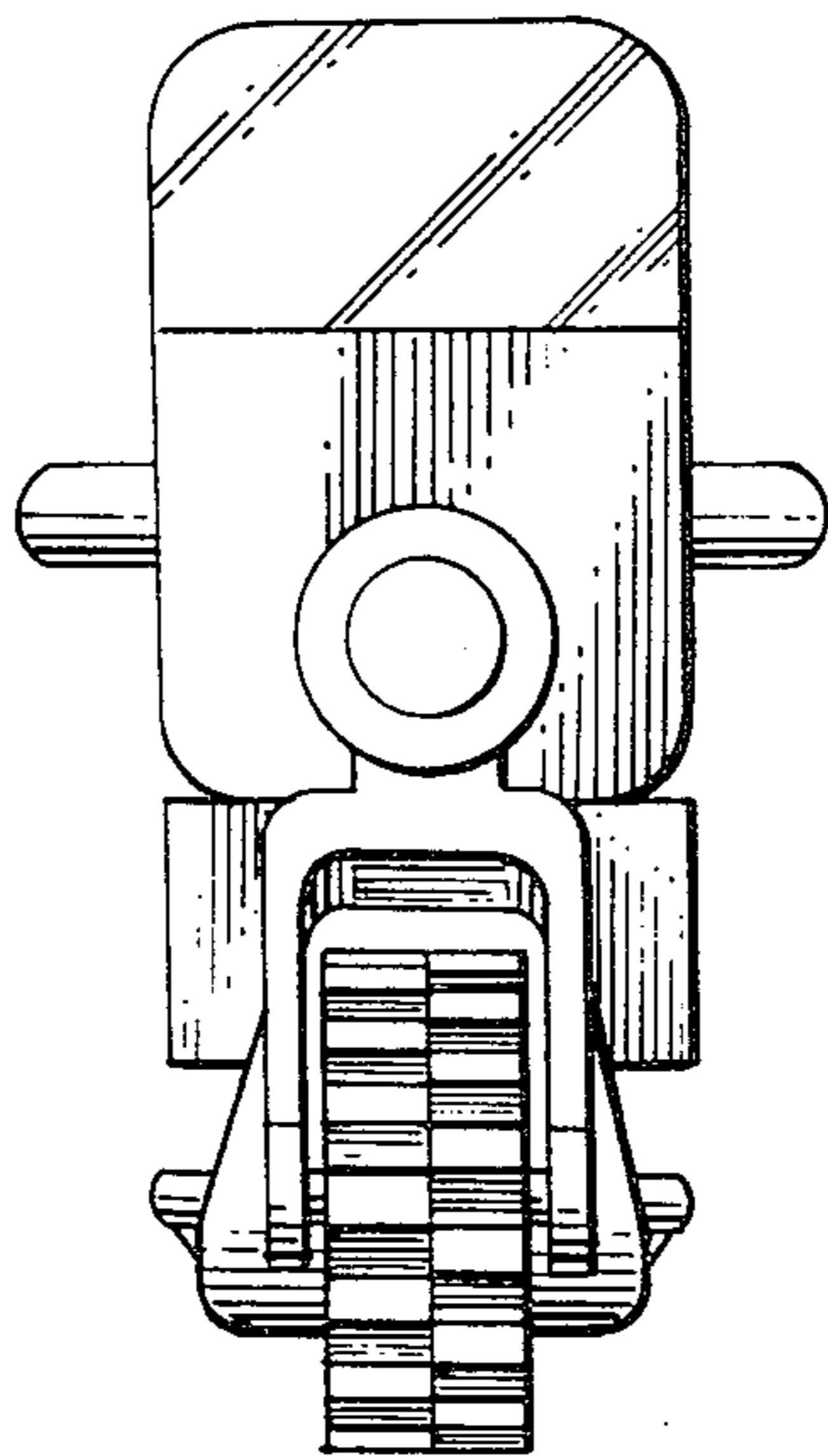

FIG. 4.

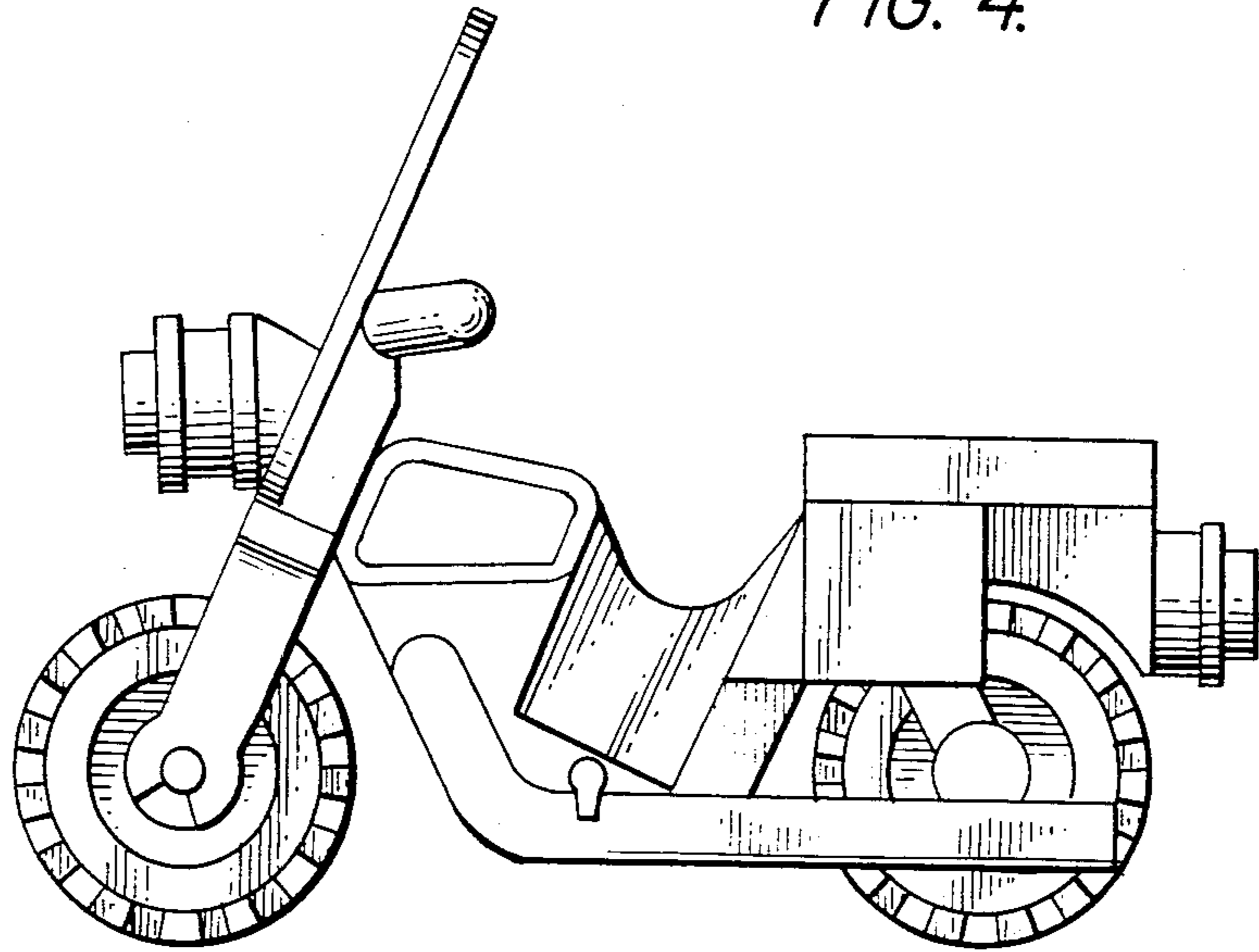

FIG. 5.

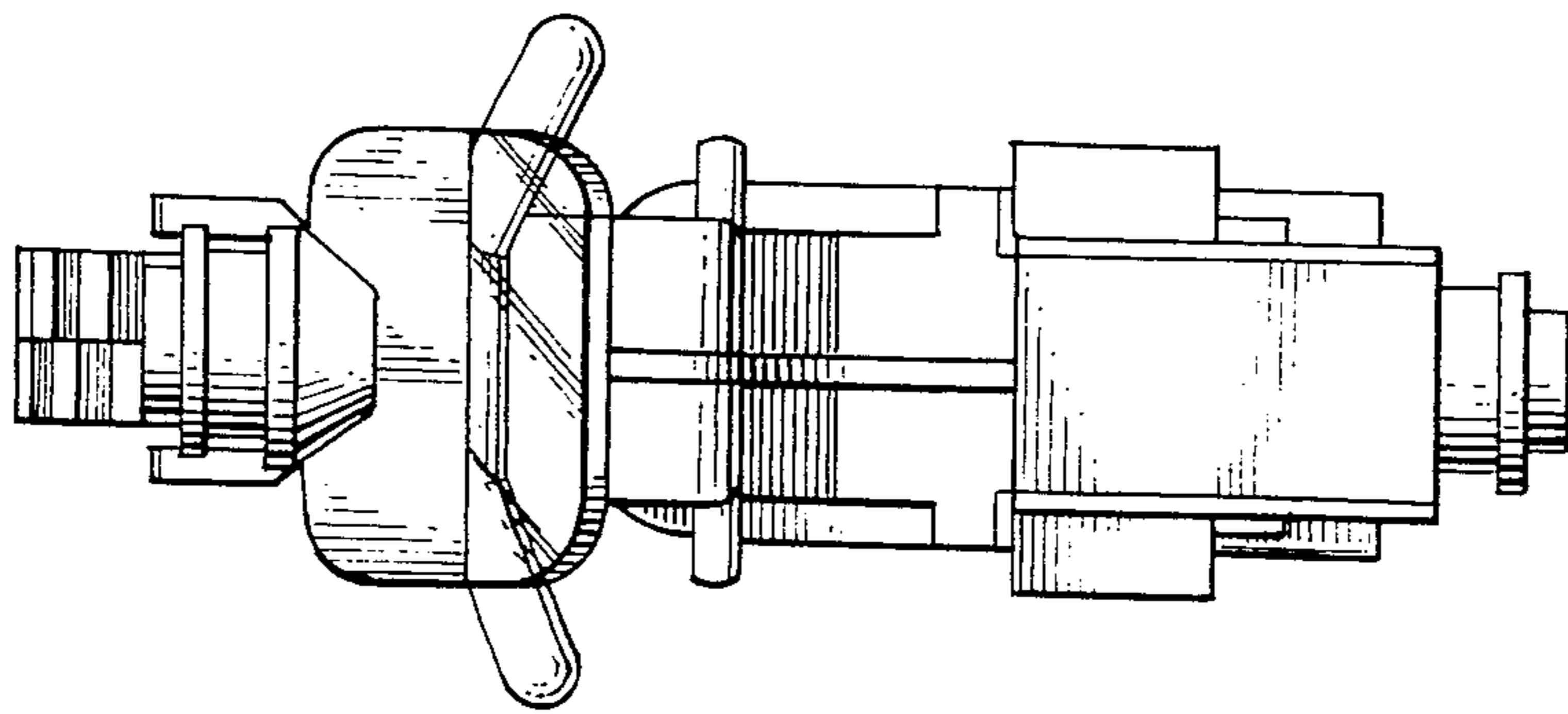

FIG. 6.

