

[54] MULTIMETER HOLSTER

[75] Inventor: Michael D. Nelson, Seattle, Wash.

[73] Assignee: John Fluke Mfg. Co., Inc., Everett, Wash.

[**] Term: 14 Years

[21] Appl. No.: 551,671

[22] Filed: Nov. 14, 1983

[52] U.S. Cl. D2/400

[58] Field of Search D2/400; D10/78, 80, D10/128; 224/191, 902, 251, 197, 252

[56] References Cited

U.S. PATENT DOCUMENTS

D. 250,974	1/1979	Donley et al.	D2/400 X
4,046,295	9/1977	Eichler	224/251 X
4,299,344	11/1981	Yamashita et al.	224/252 X

Primary Examiner—Bernard Ansher
Assistant Examiner—Theodore M. Shooman
Attorney, Agent, or Firm—Mikio Ishimaru; Stephen A. Becker

[57] CLAIM

The ornamental design for a multimeter holster, as shown and described.

DESCRIPTION

FIG. 1 is a front elevation view of a multimeter holster showing my new design;
FIG. 2 is a side elevation view thereof, the opposite side being a mirror image;
FIG. 3 is a top plan view thereof;
FIG. 4 is a bottom plan view thereof;
FIG. 5 is a rear elevation view thereof; and
FIG. 6 is a side view thereof, with support element shown in open position.

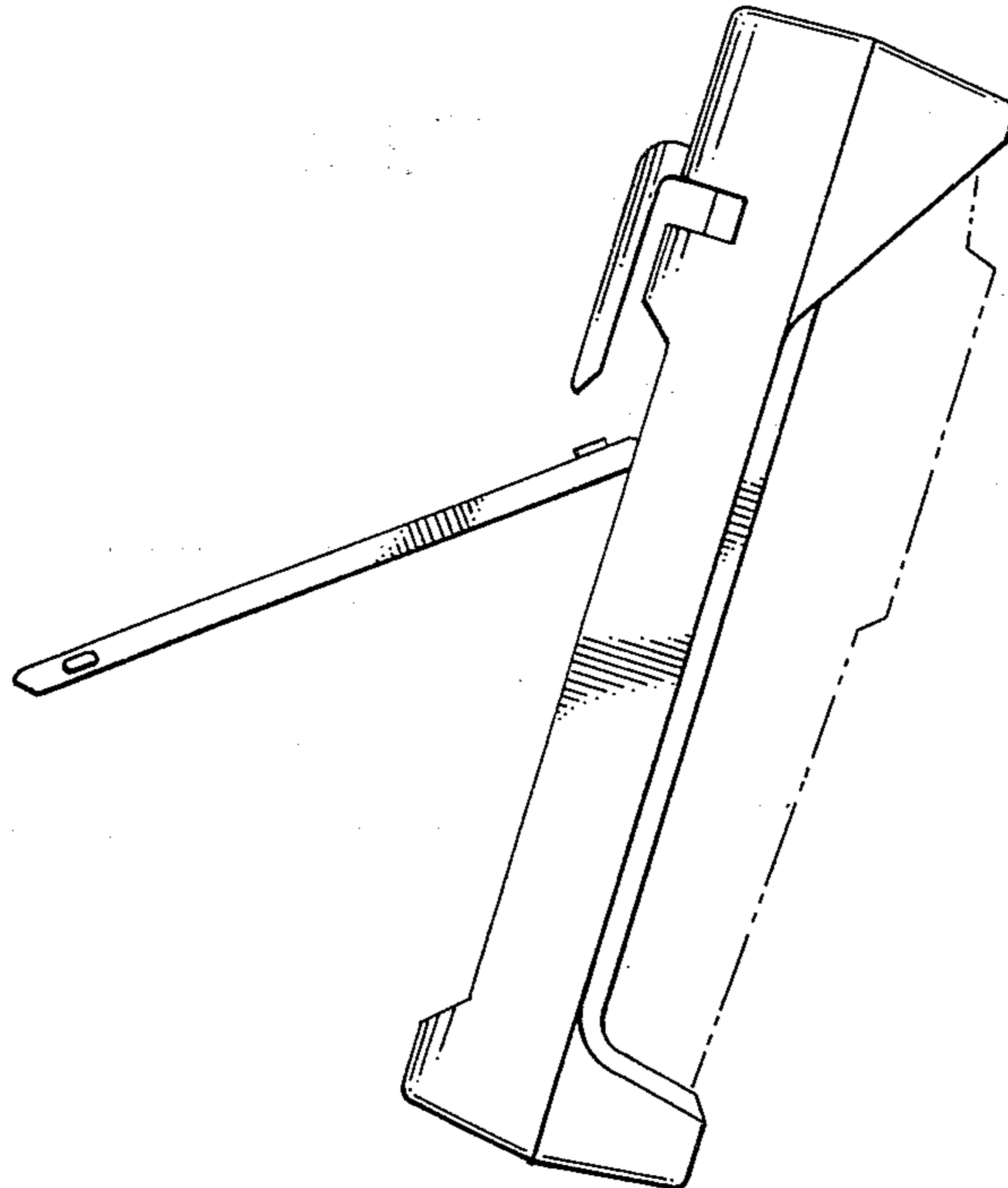

FIG. 1

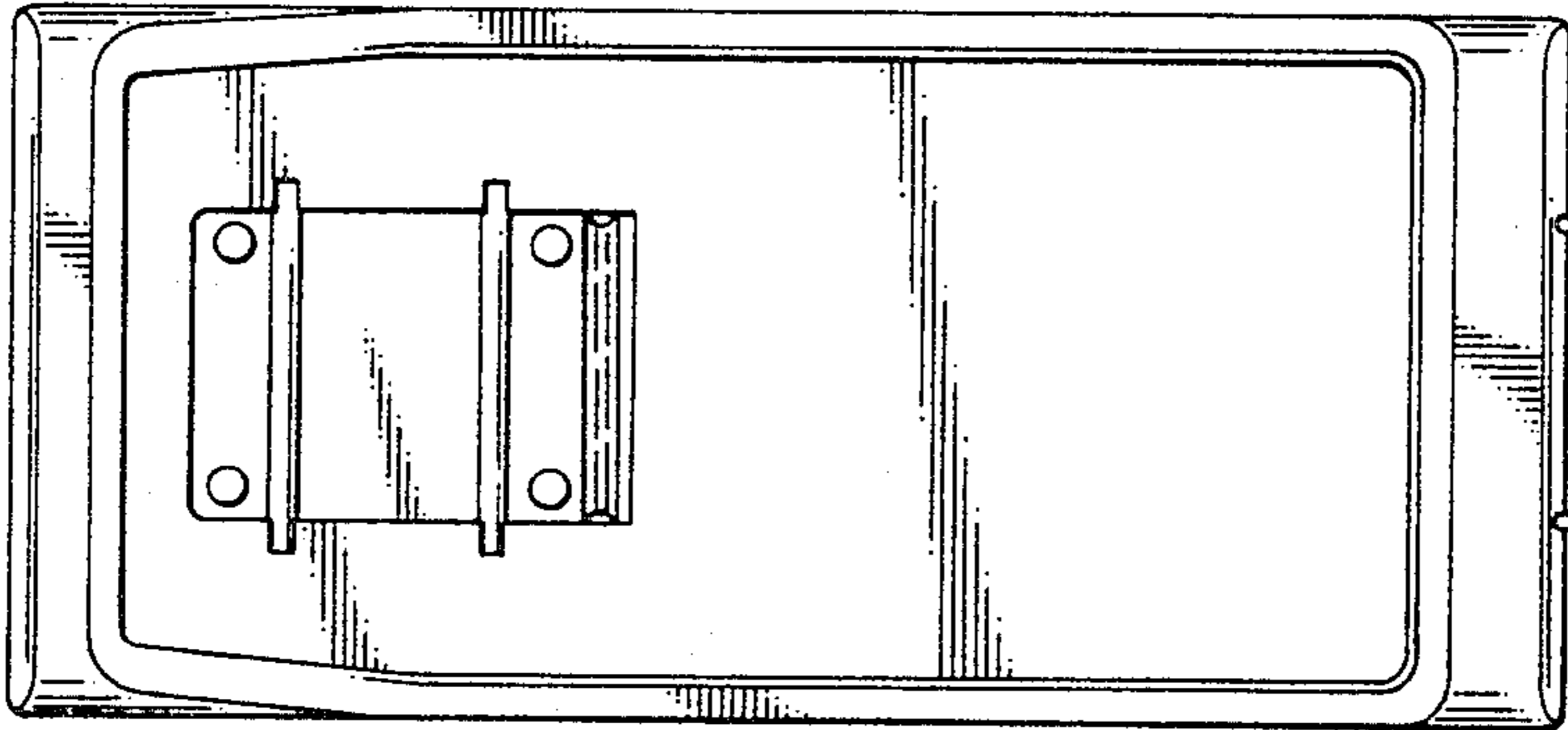

FIG. 2

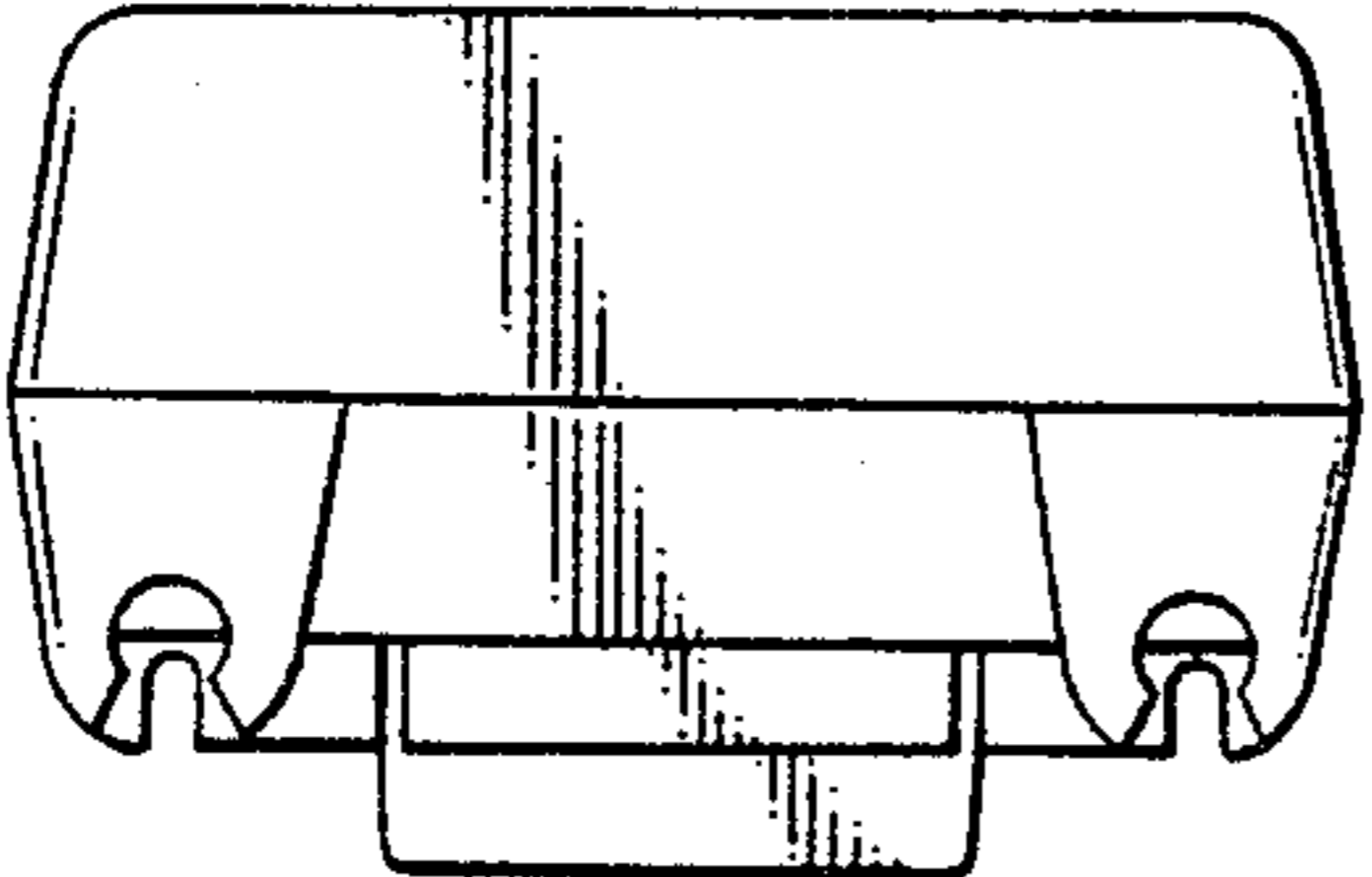
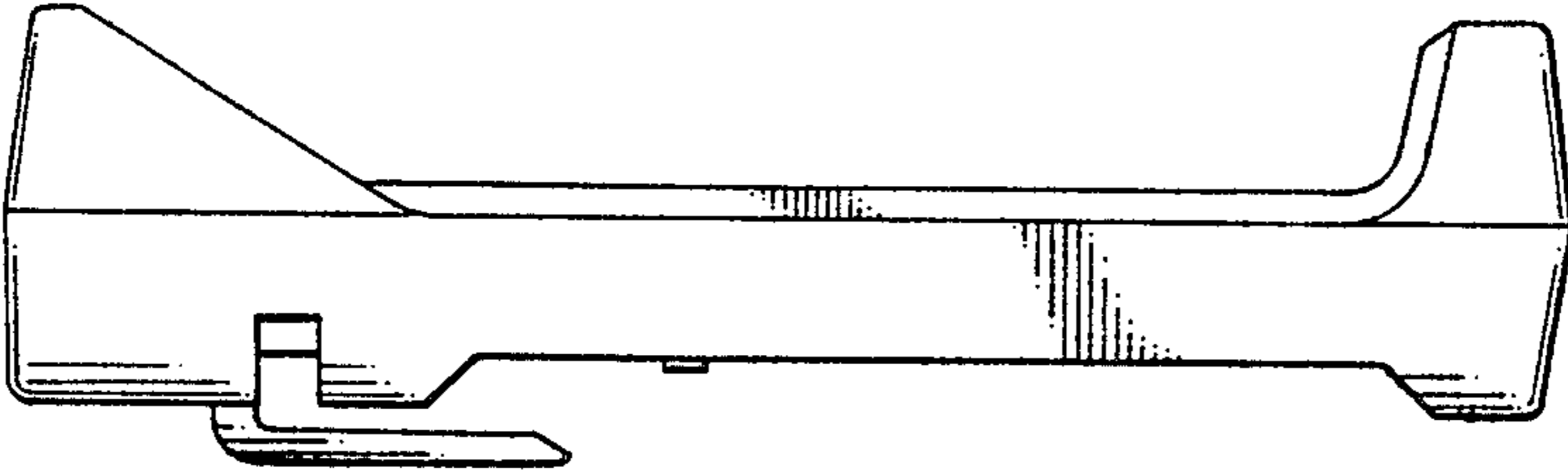

FIG. 3

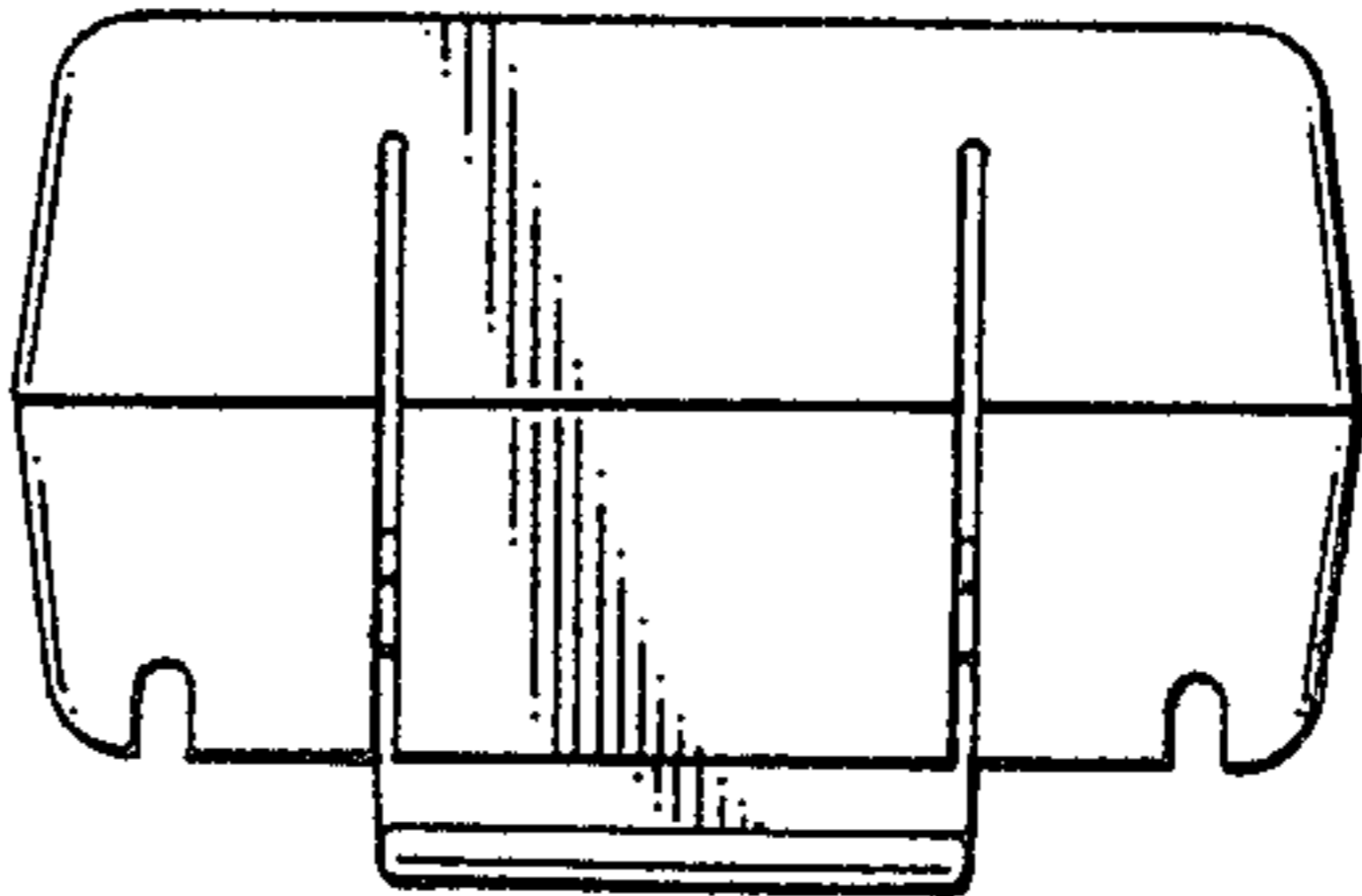

FIG. 4

FIG. 5

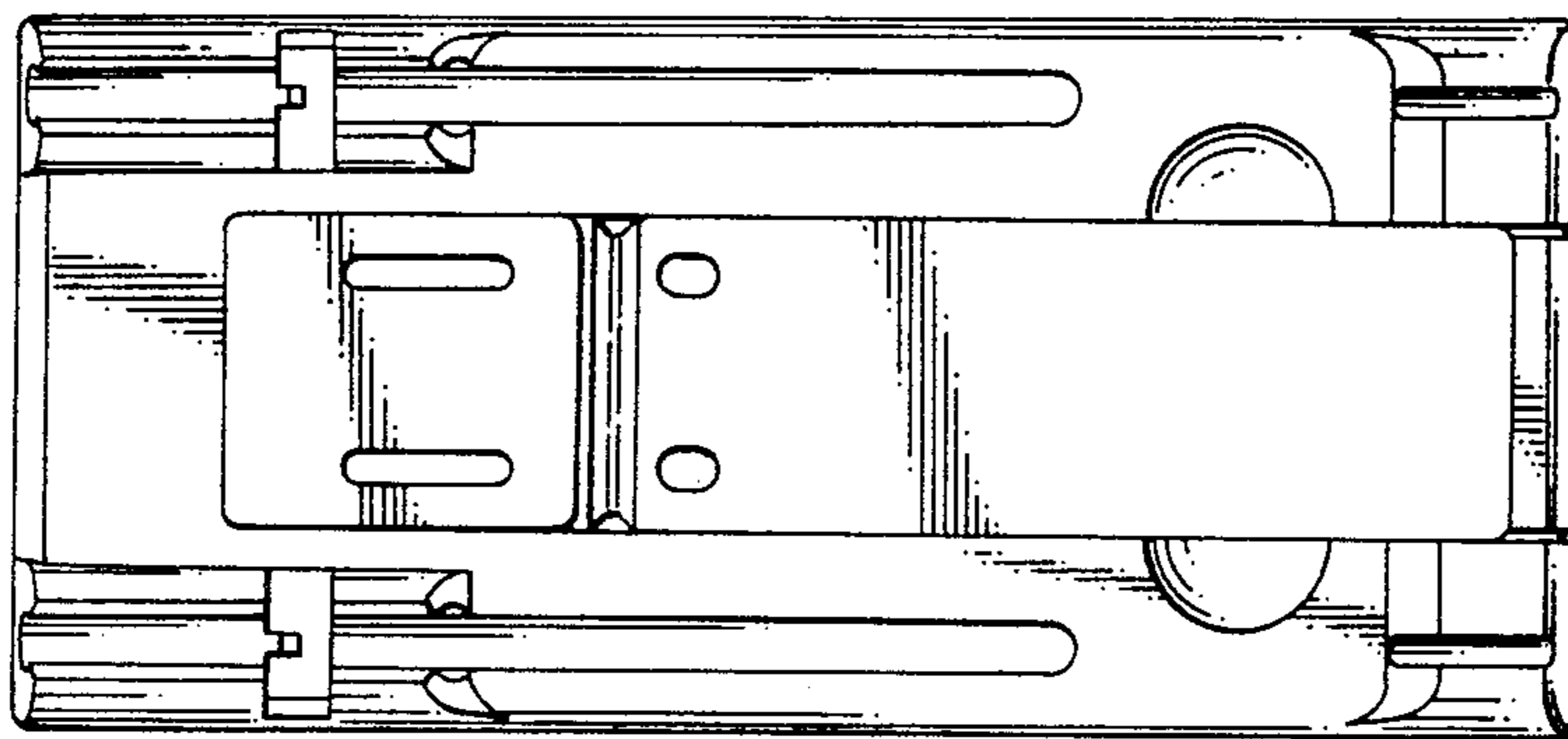

FIG. 6

