

[54] CONTROL AND METER HOUSING FOR A BATTERY JUMPER CABLE SYSTEM

[75] Inventor: Bobby L. Bates, San Dimas, Calif.

[73] Assignee: Bates-Johnson & Co., Inc., San Dimas, Calif.

[\*\*] Term: 14 Years

[21] Appl. No.: 381,058

[22] Filed: May 24, 1982

[52] U.S. Cl. .... D13/10; D13/5; D13/41

[58] Field of Search ..... D13/4, 5, 8-12, D13/15, 40, 41; D10/75, 77, 80, 49; 339/28 R, 29 R, 29 B, 113 L; 200/51 R, 51 H; 429/121, 90, 92, 93, 96-100

[56] References Cited

U.S. PATENT DOCUMENTS

|           |         |           |       |            |
|-----------|---------|-----------|-------|------------|
| D. 97,286 | 10/1935 | Heyer     | ..... | D10/77     |
| 1,557,248 | 10/1925 | Gernsback | ..... | 339/29 R X |
| 1,949,634 | 3/1934  | Simpson   | ..... | 361/380    |
| 2,229,009 | 1/1941  | Berry     | ..... | D10/77 X   |
| 4,166,241 | 8/1979  | Grant     | ..... | 339/29 B X |

OTHER PUBLICATIONS

J. C. Whitney Auto Accessories Catalog, ©1979, p. 135, Electronic Ignition System Analyzer.  
 J. C. Whitney Auto Accessories Catalog, ©1979, p. 135, Emergency Ignition.  
 J. C. Whitney Auto Accessories Catalog, ©1979, p. 136, UL Listed Battery Charger.  
 Mart, 4-1958, p. 26, #3, Remote Control (Electrical Switch pub Box).

Primary Examiner—Susan J. Lucas  
 Attorney, Agent, or Firm—Christie, Parker & Hale

[57] CLAIM

The ornamental design for a control and meter housing for a battery jumper cable system, substantially as shown and described.

DESCRIPTION

FIG. 1 is a pictorial view of a control and meter housing for a battery jumper cable system showing my new design, the cables and clamps being shown in broken lines for illustrative purposes only;  
 FIG. 2 is a top view of a second embodiment of my new design;  
 FIG. 3 is a side view common to both embodiments, the opposite side being identical;  
 FIG. 4 is a bottom view common to both embodiments; and  
 FIG. 5 is an end view common to both embodiments, the opposite end being identical.

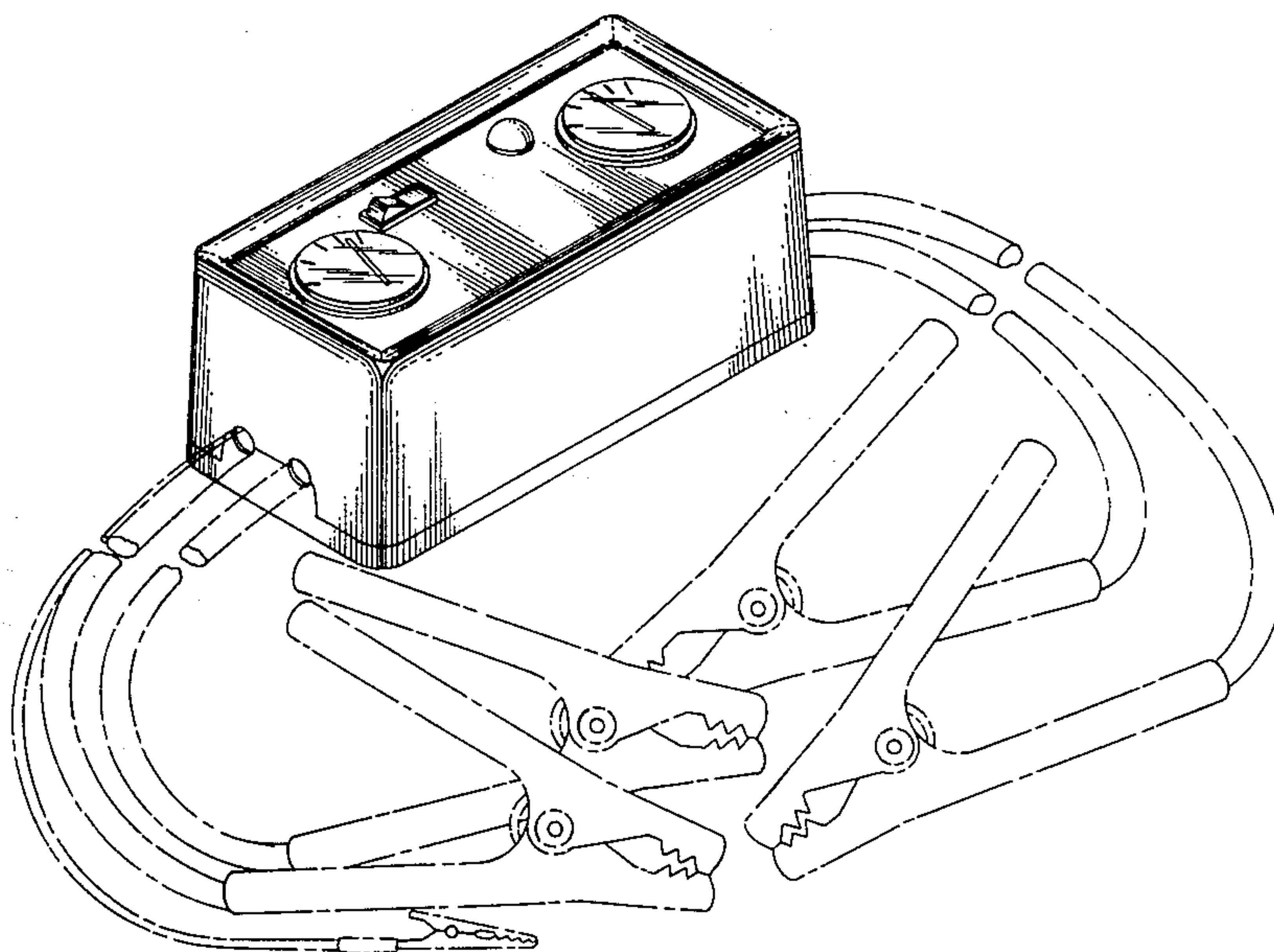

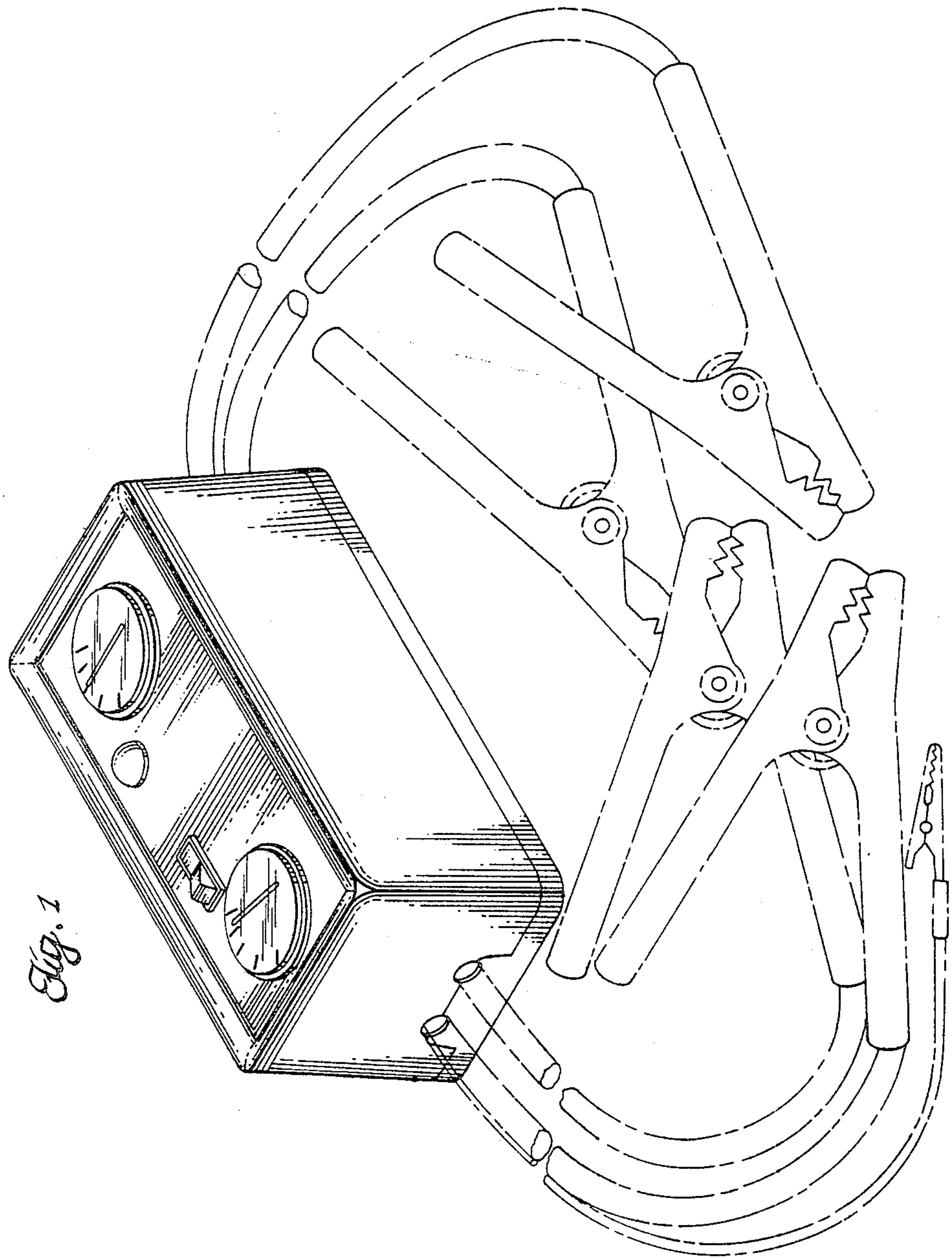
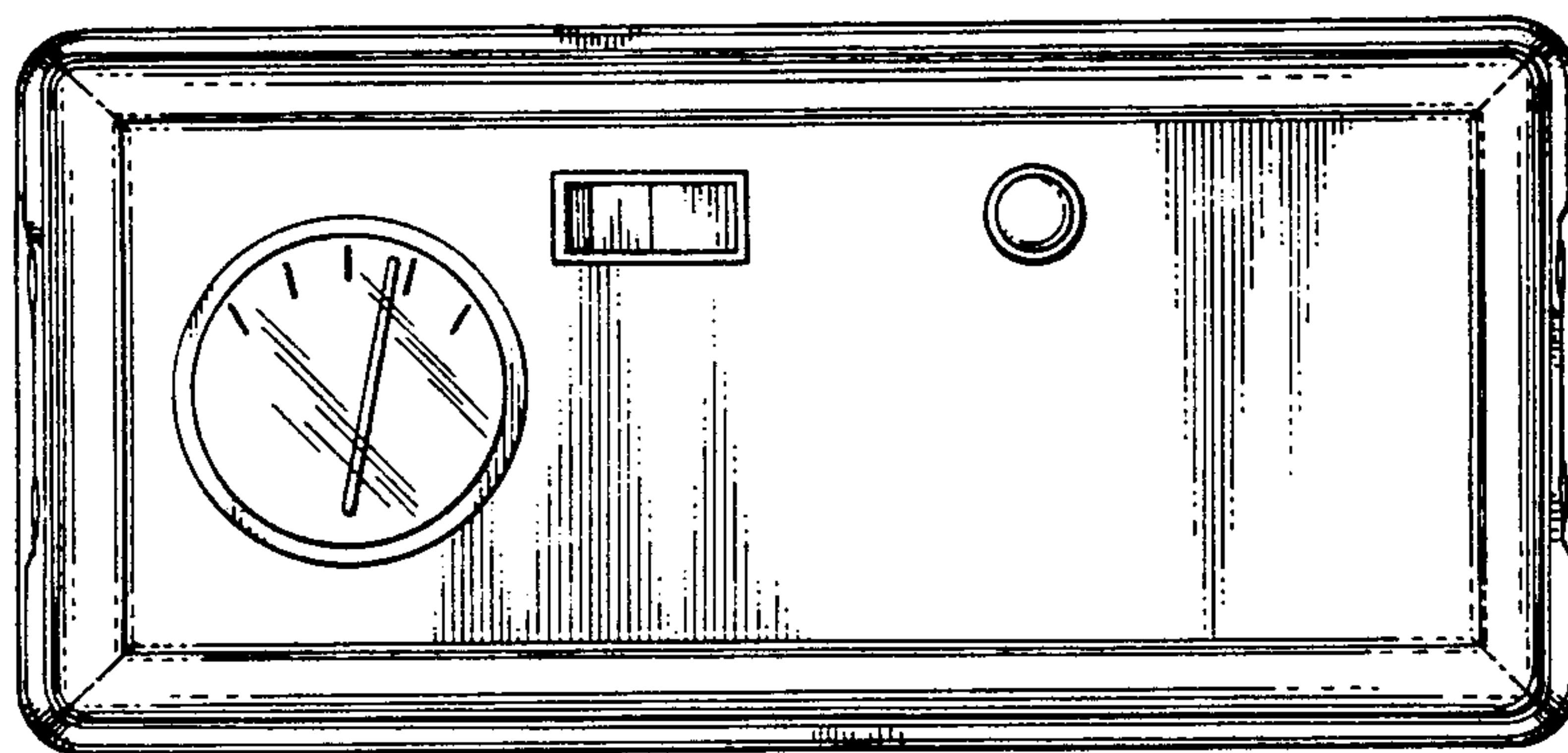
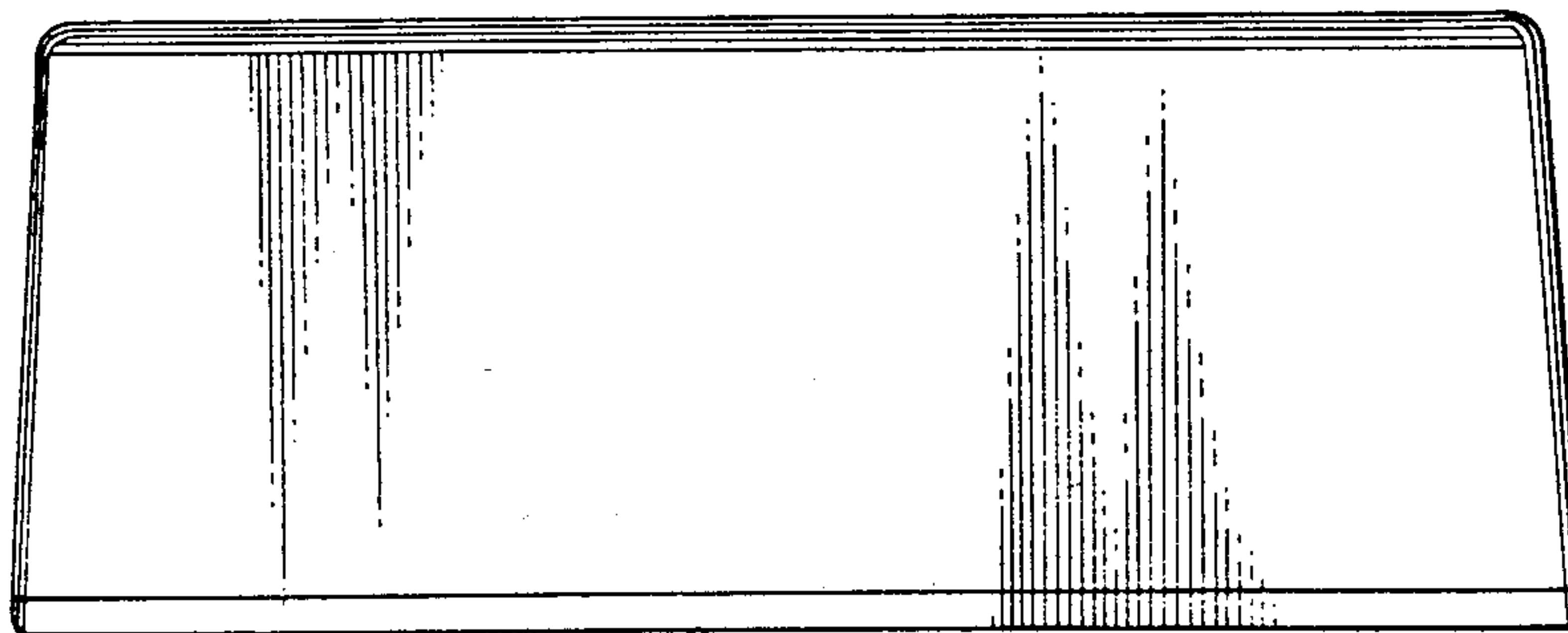

Fig. 1

*Fig. 2*



*Fig. 3*



*Fig. 4*

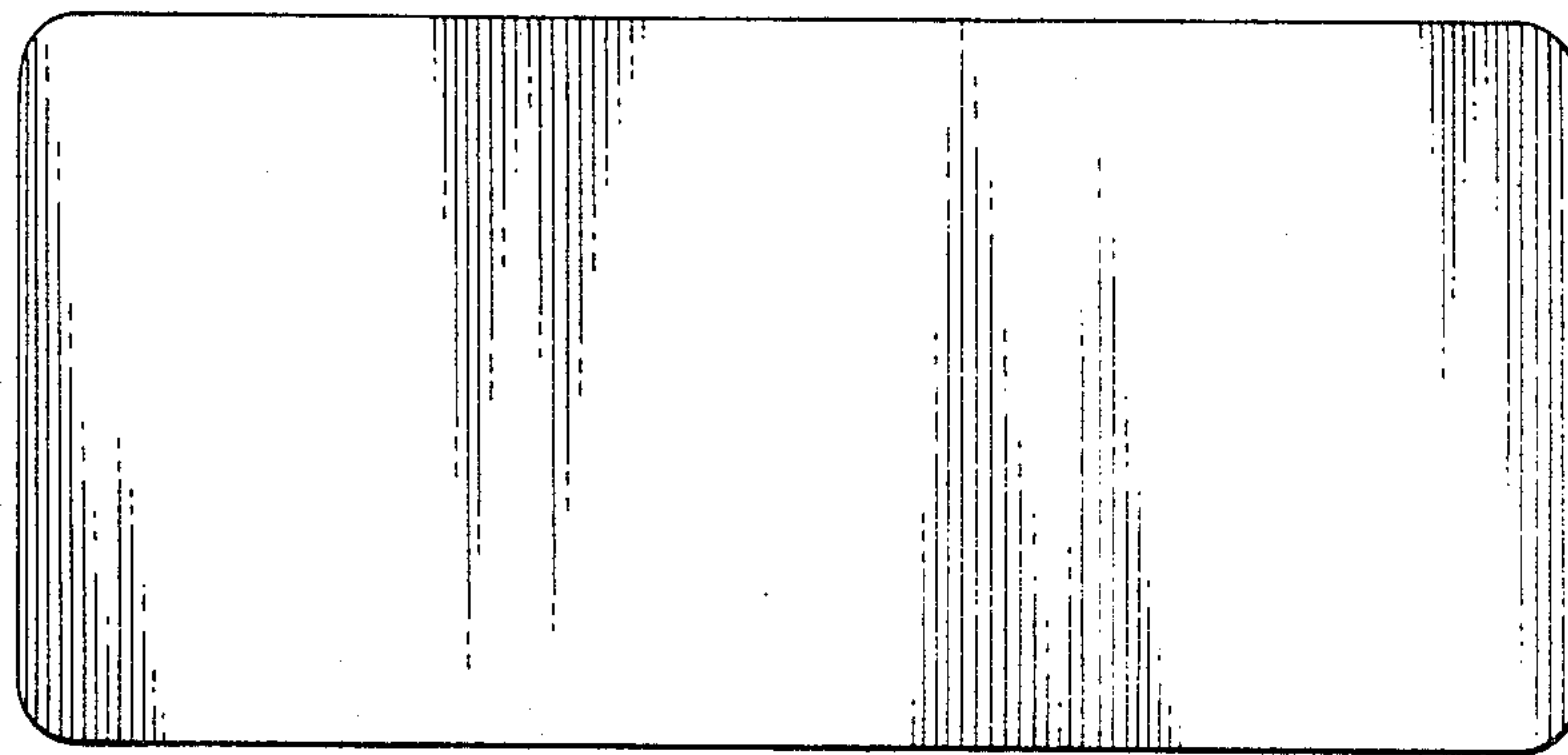

*Fig. 5*

