

[54] VEHICLE WHEEL STOP MAT

[76] Inventor: Maynard E. Nelson, 2421 Brookwood, Salina, Kans. 67401

[**] Term: 14 Years

[21] Appl. No.: 476,832

[22] Filed: Mar. 18, 1983

[52] U.S. Cl. D12/217

[58] Field of Search D12/217; 188/32

[56] References Cited

U.S. PATENT DOCUMENTS

- D. 253,408 11/1979 Sargent D12/217
- 2,746,571 5/1956 Taylor 188/32

3,922,824 12/1975 Izawa et al. D25/74

Primary Examiner—James M. Gandy
Attorney, Agent, or Firm—Phillip A. Rein

[57] CLAIM

The ornamental design for a vehicle wheel stop mat, as shown.

DESCRIPTION

FIG. 1 is a perspective view of the vehicle wheel stop mat showing my new design;
FIG. 2 is a side elevational view thereof;
FIG. 3 is a top plan view thereof;
FIG. 4 is a bottom plan view thereof; and
FIG. 5 is a front elevational view thereof.

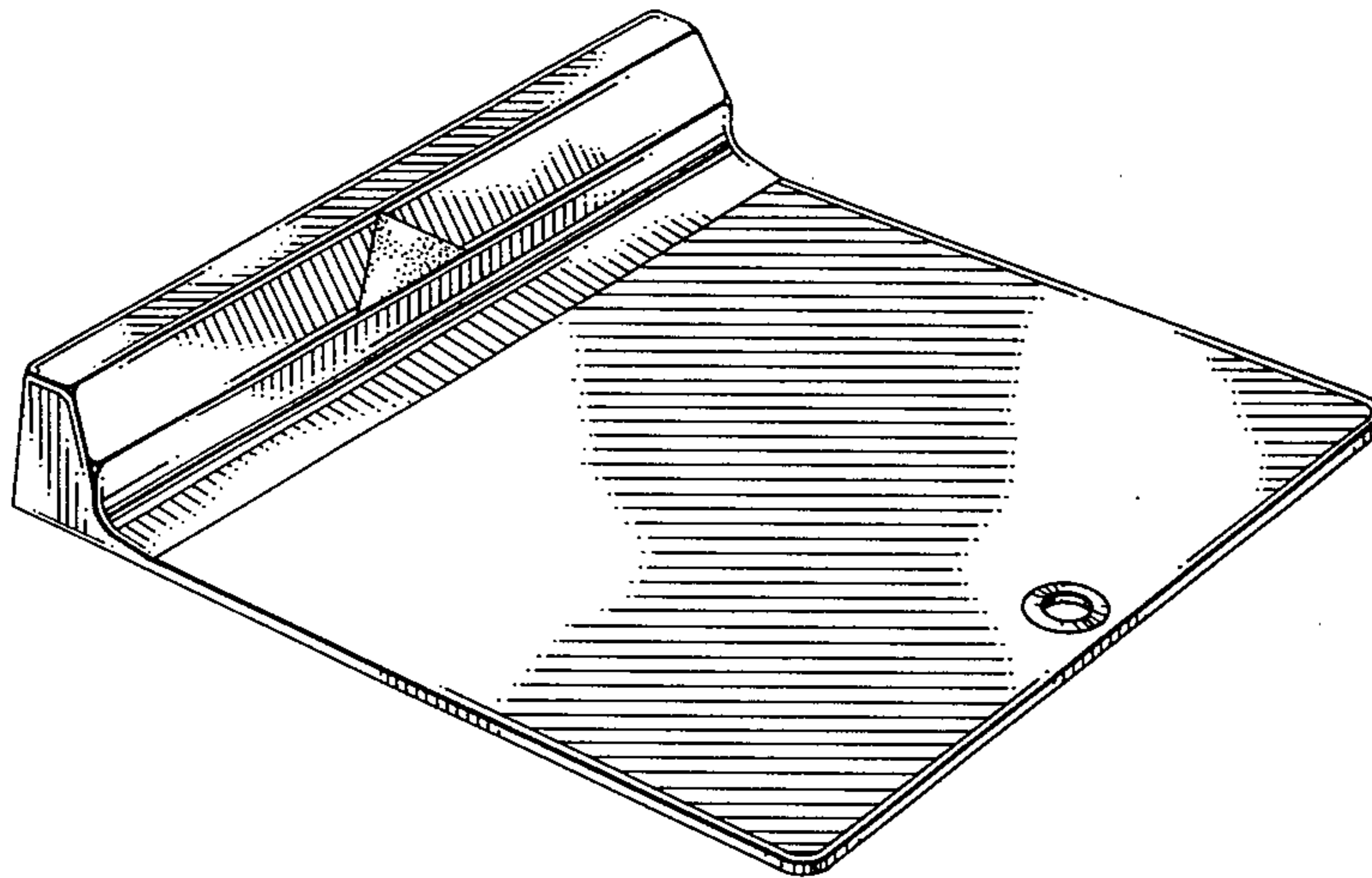

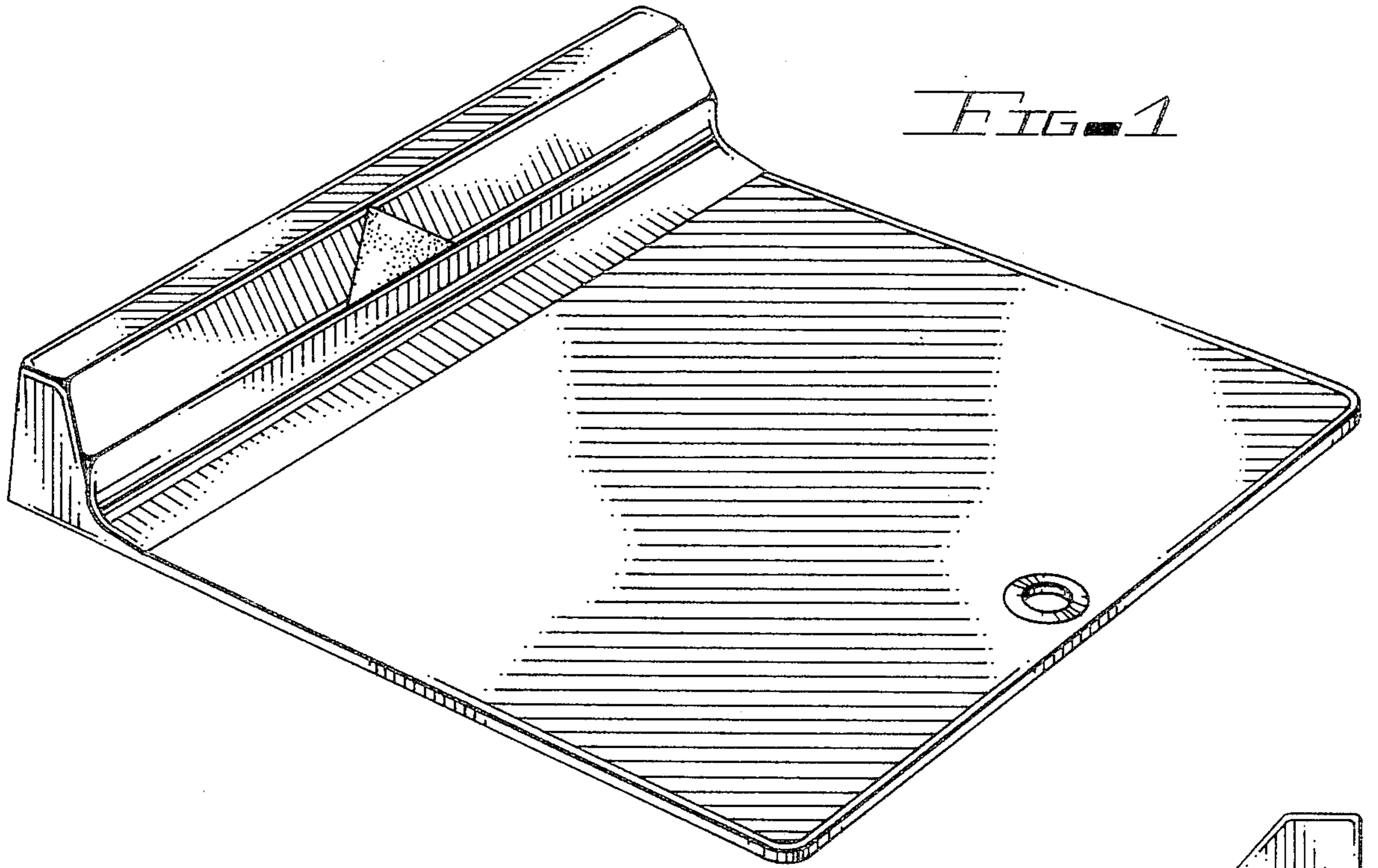

FIG. 1

FIG. 2

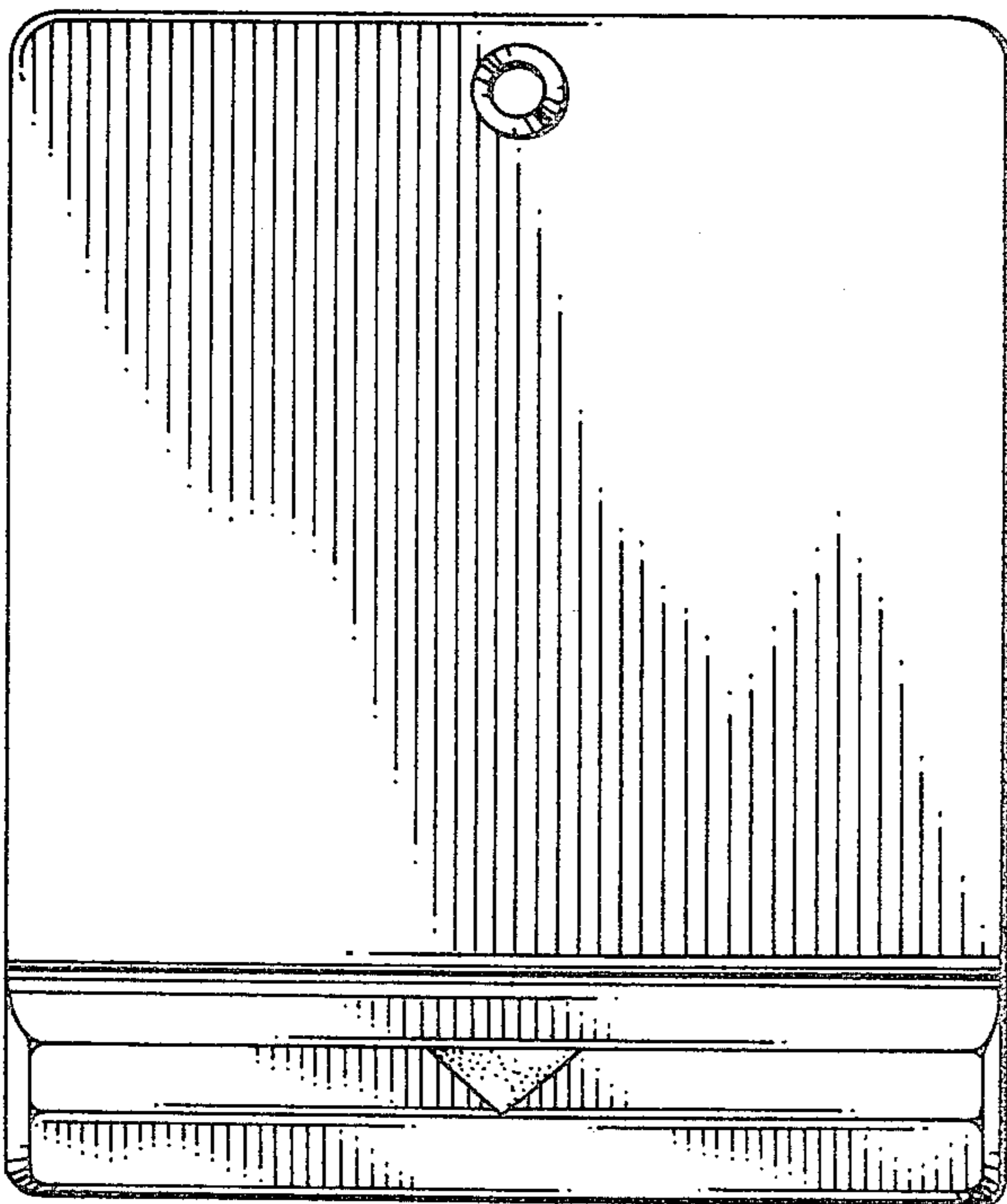
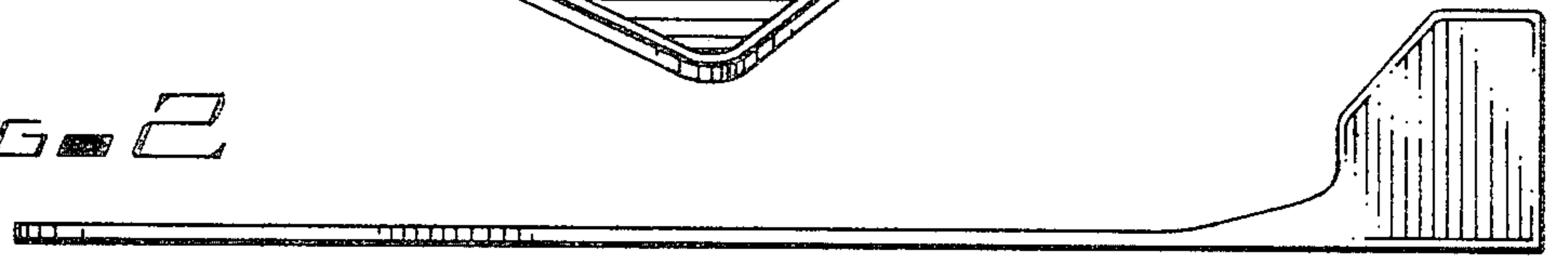

FIG. 3

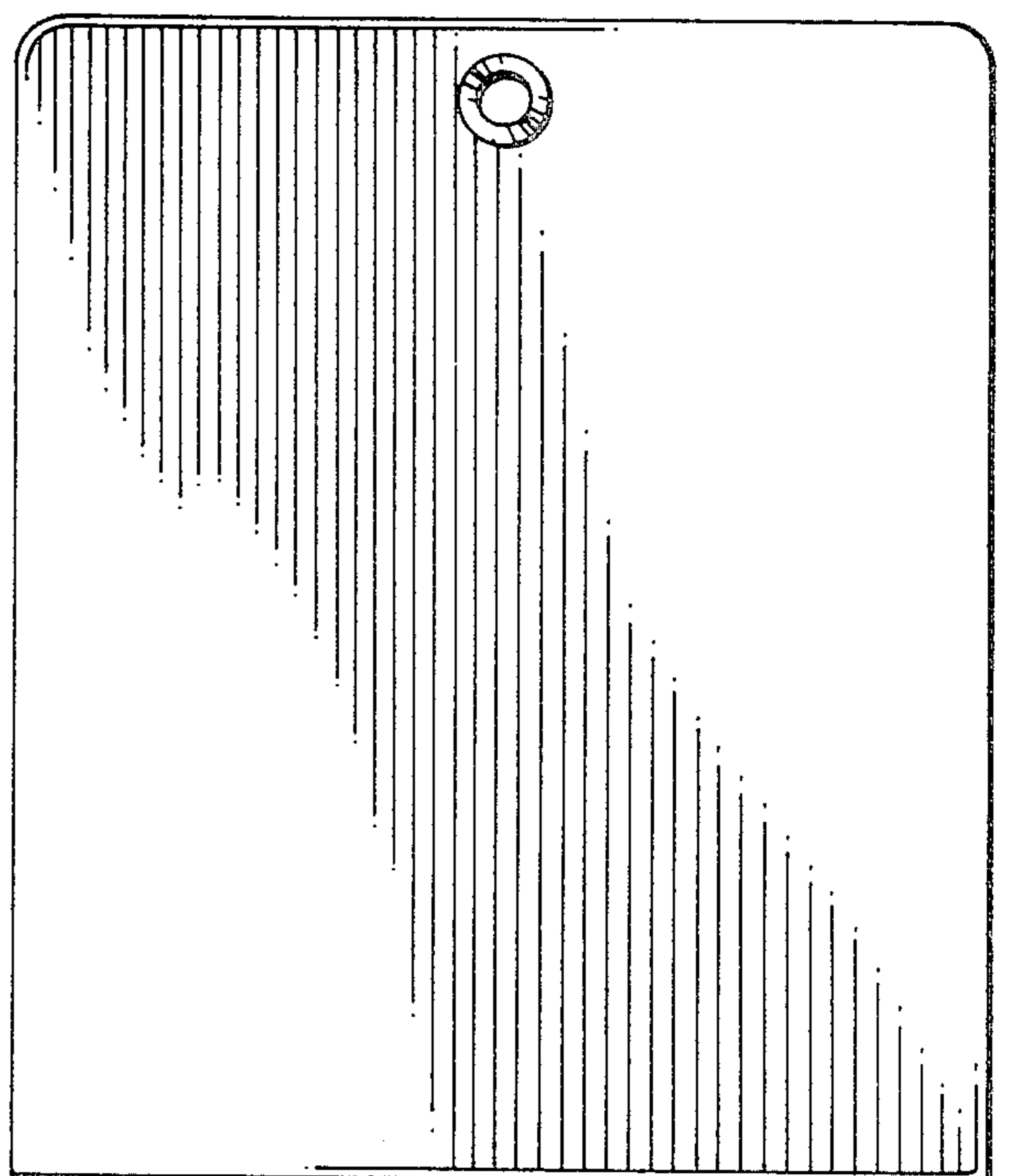

FIG. 4

FIG. 5

