

[54] **MOTORCYCLE AIR ENTRY FAIRING**

[75] **Inventors:** Hubert Walter, Penzberg;
Hans-Joachim Saaksmeier, Munich,
both of Fed. Rep. of Germany

[73] **Assignee:** Bayerische Motoren Werke A.G.,
Munich, Fed. Rep. of Germany

[**] **Term:** 14 Years

[21] **Appl. No.:** 477,662

[22] **Filed:** Mar. 22, 1983

[30] **Foreign Application Priority Data**

Sep. 24, 1982 [DE] Fed. Rep. of Germany ... MR 13095

[52] **U.S. Cl.** D12/182

[58] **Field of Search** D12/114, 182; 296/78.1;
280/289 G, 289 S

[56] **References Cited**

U.S. PATENT DOCUMENTS

D. 252,081 6/1979 Melby D12/114

D. 264,704 6/1982 Rehberg D12/114

OTHER PUBLICATIONS

Road & Track, 2/82, p. 132, Front Grille of BMW 528e,
center of page.

Primary Examiner—James M. Gandy
Attorney, Agent, or Firm—Craig & Burns

[57] **CLAIM**

The ornamental design for a motorcycle air entry fairing,
as shown and described.

DESCRIPTION

FIG. 1 is a perspective view from in front and the left
side of the motorcycle air entry fairing embodying our
novel design;

FIG. 2 is a front elevational view thereof;

FIG. 3 is a left side elevational view thereof;

FIG. 4 is a right side elevational view thereof;

FIG. 5 is a rear elevational view thereof;

FIG. 6 is a top plan view thereof; and

FIG. 7 is a bottom plan view thereof.

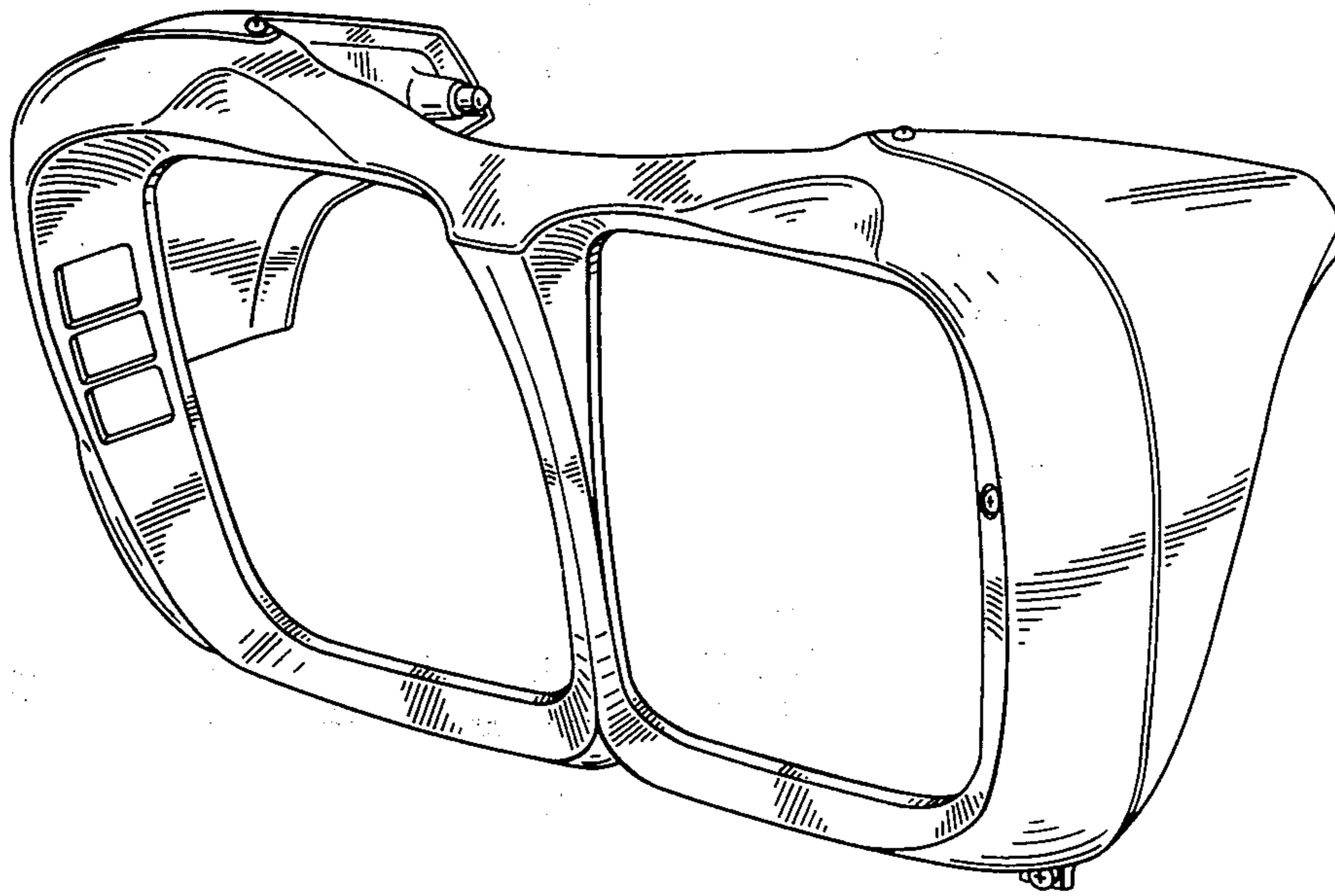

Fig. 1

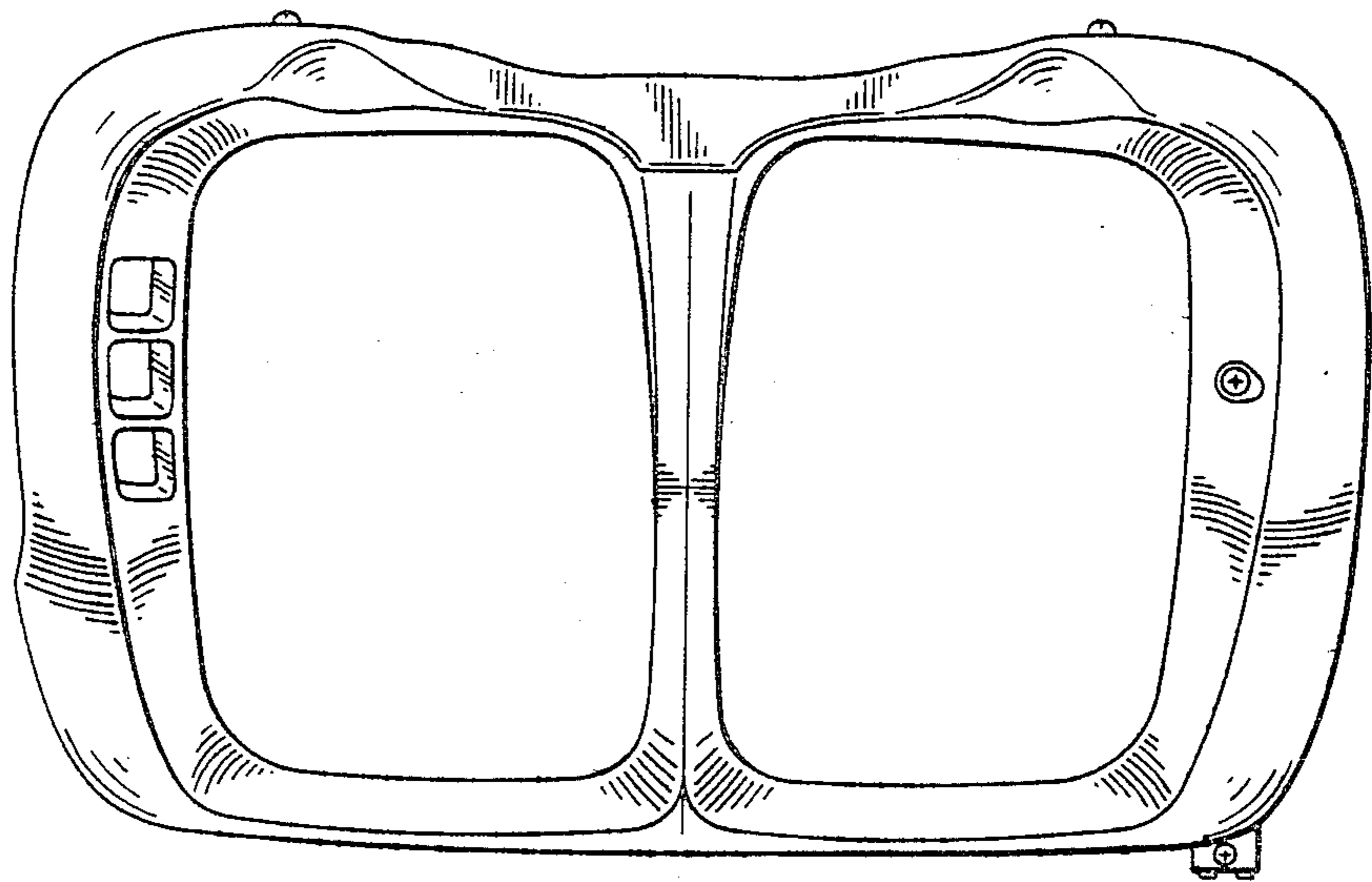
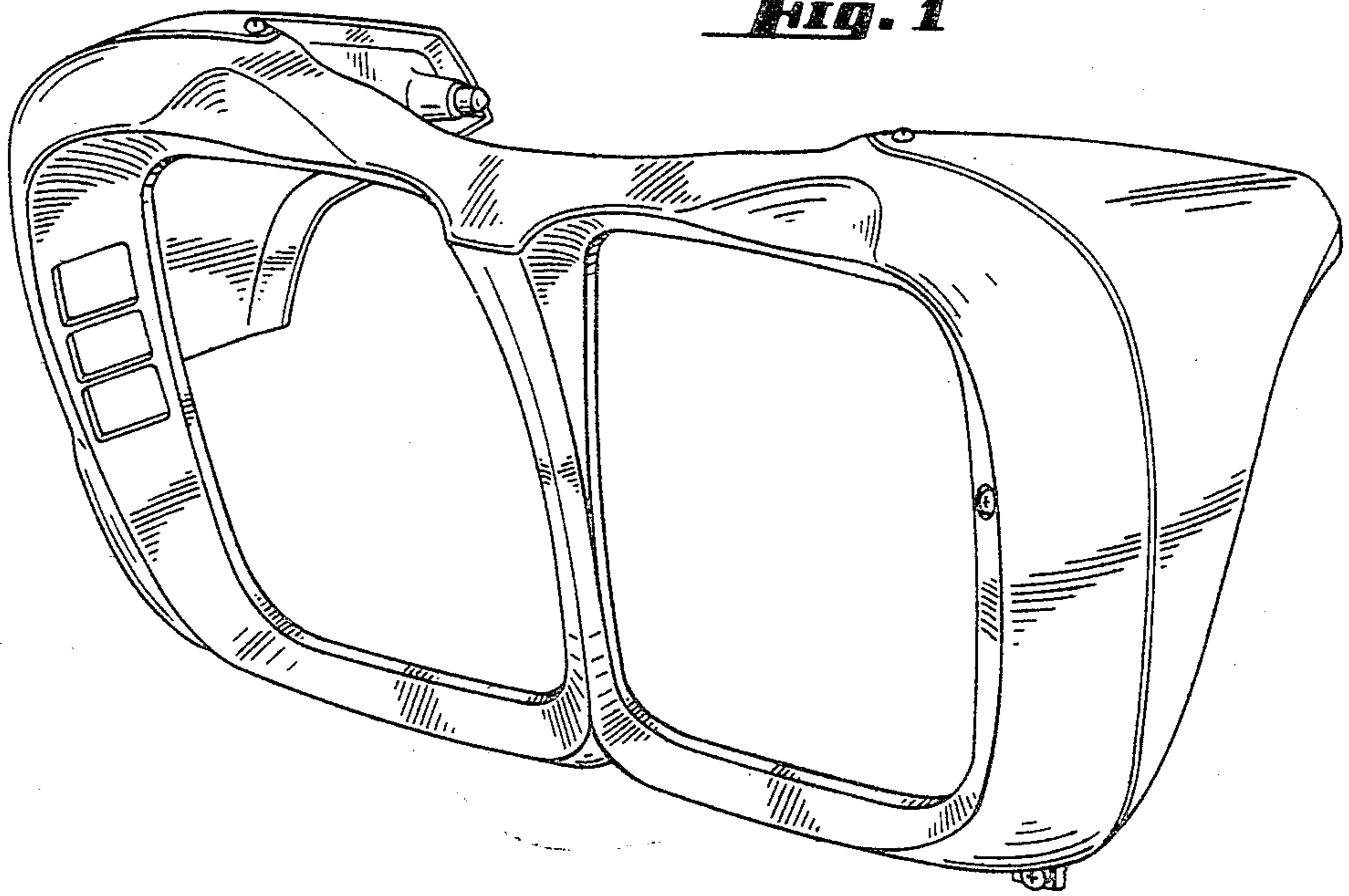

Fig. 2

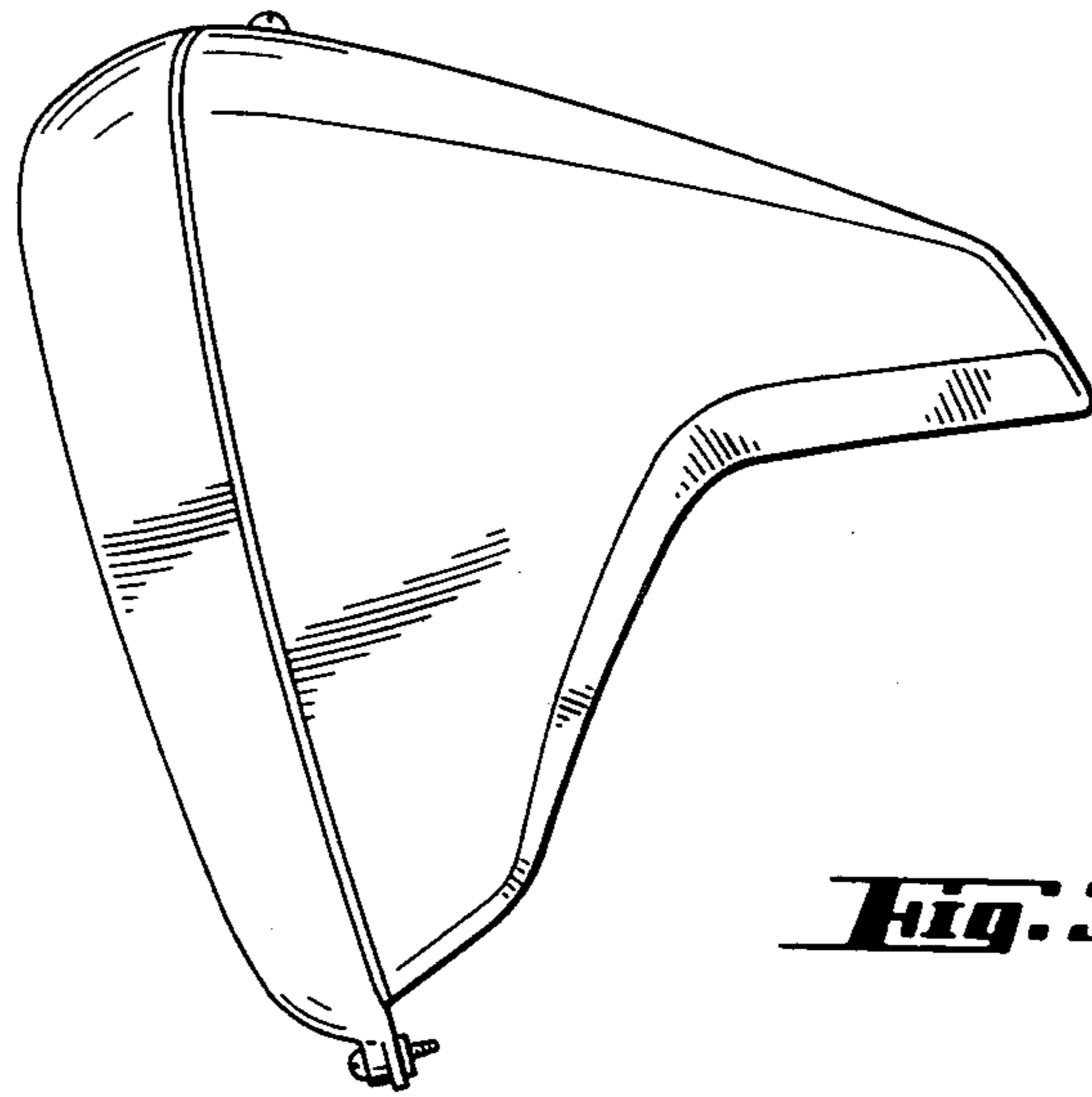

Fig. 3

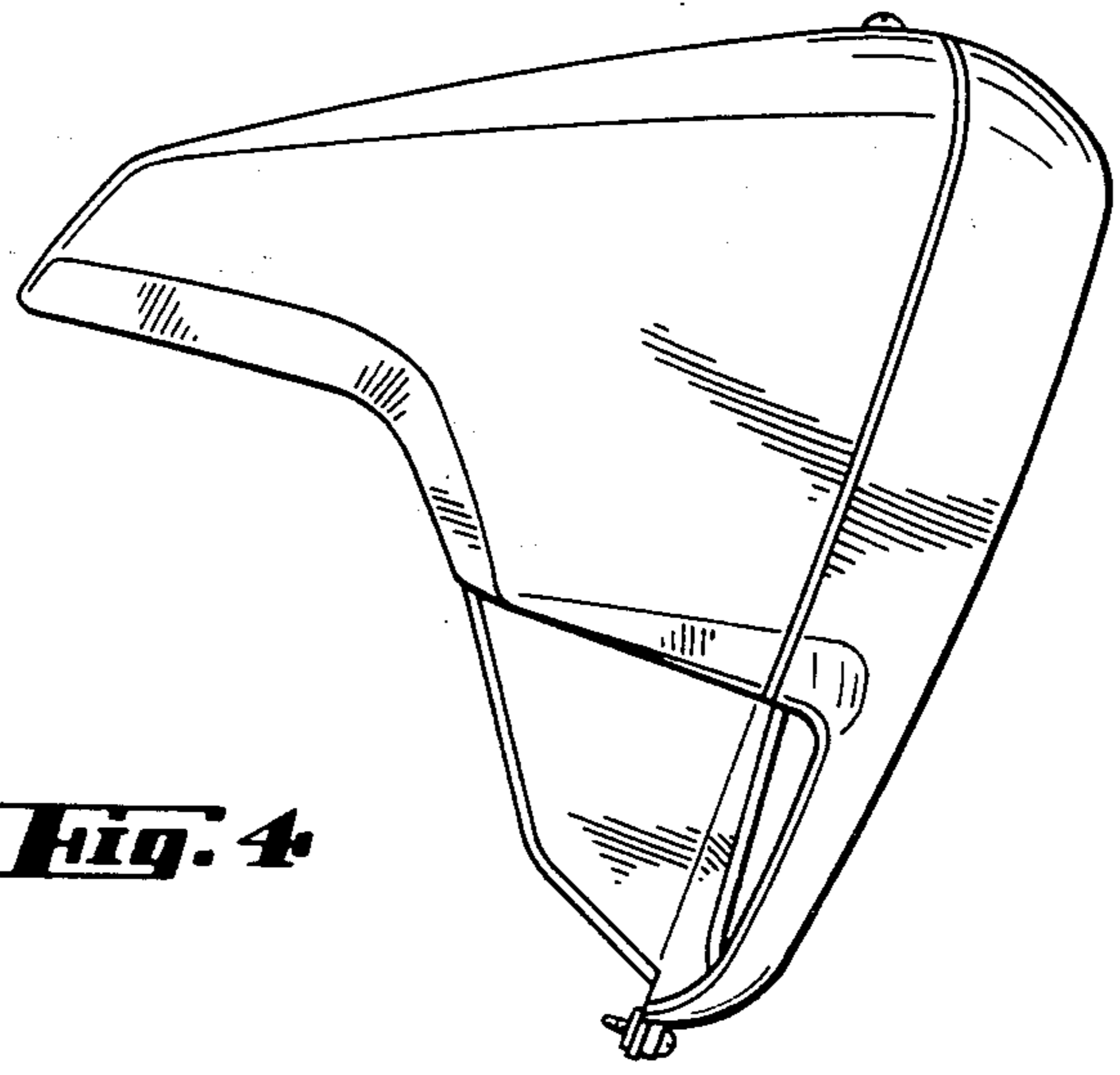

Fig. 4

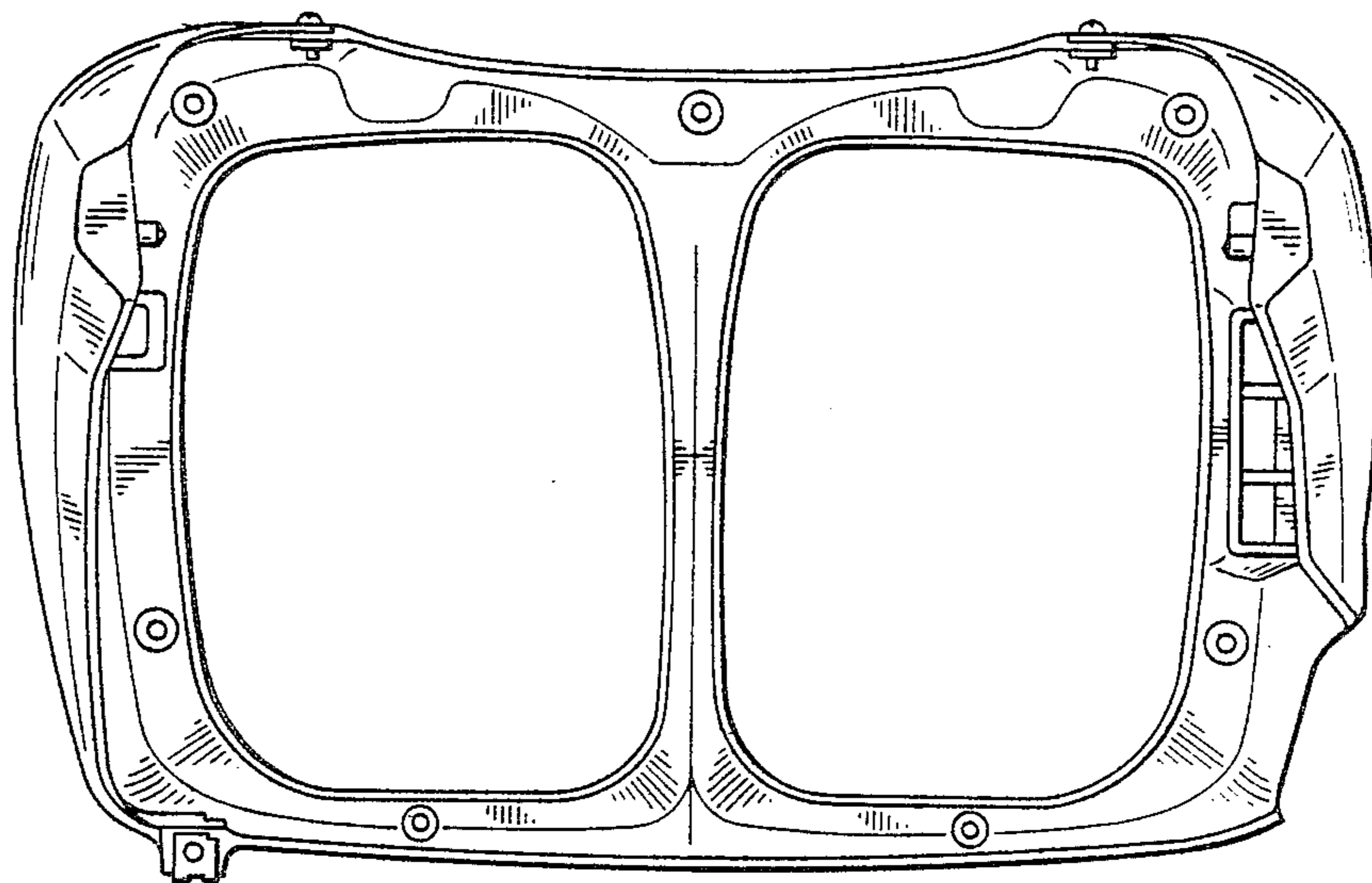

Fig. 5

