

[54] BUMPER EXTENSION

[75] Inventor: Jan Wilsgaard, Kullavik, Sweden

[73] Assignee: Aktiebolaget Volvo, Gothenburg, Sweden

[**] Term: 14 Years

[21] Appl. No.: 393,703

[22] Filed: Jun. 30, 1982

[30] Foreign Application Priority Data

Dec. 30, 1981 [SE] Sweden 81-3068

[52] U.S. Cl. D12/172

[58] Field of Search D12/169, 172; 293/126, 293/128, 149, 141, 154, 120, 102

[56] References Cited

U.S. PATENT DOCUMENTS

D. 247,745 4/1978 Tixier D12/172

OTHER PUBLICATIONS

Motor Trend, 8/81, p. 76, Wrap Around Portion Of Front Bumper Of Mercury Lynx.

Motor Trend, 11/81, p. 29, Side Extension Of Front Bumper Of 1982 Honda Accord, center of page.

Primary Examiner—James M. Gandy

Attorney, Agent, or Firm—Young & Thompson

[57] CLAIM

The ornamental design for a bumper extension, as shown.

DESCRIPTION

FIG. 1 is a bottom front perspective view of the outside of a bumper extension showing my new design;

FIG. 2 is a top front perspective view of the outside thereof;

FIG. 3 is a top rear perspective view of the inside thereof; and

FIG. 4 is a bottom rear perspective view of the inside thereof.

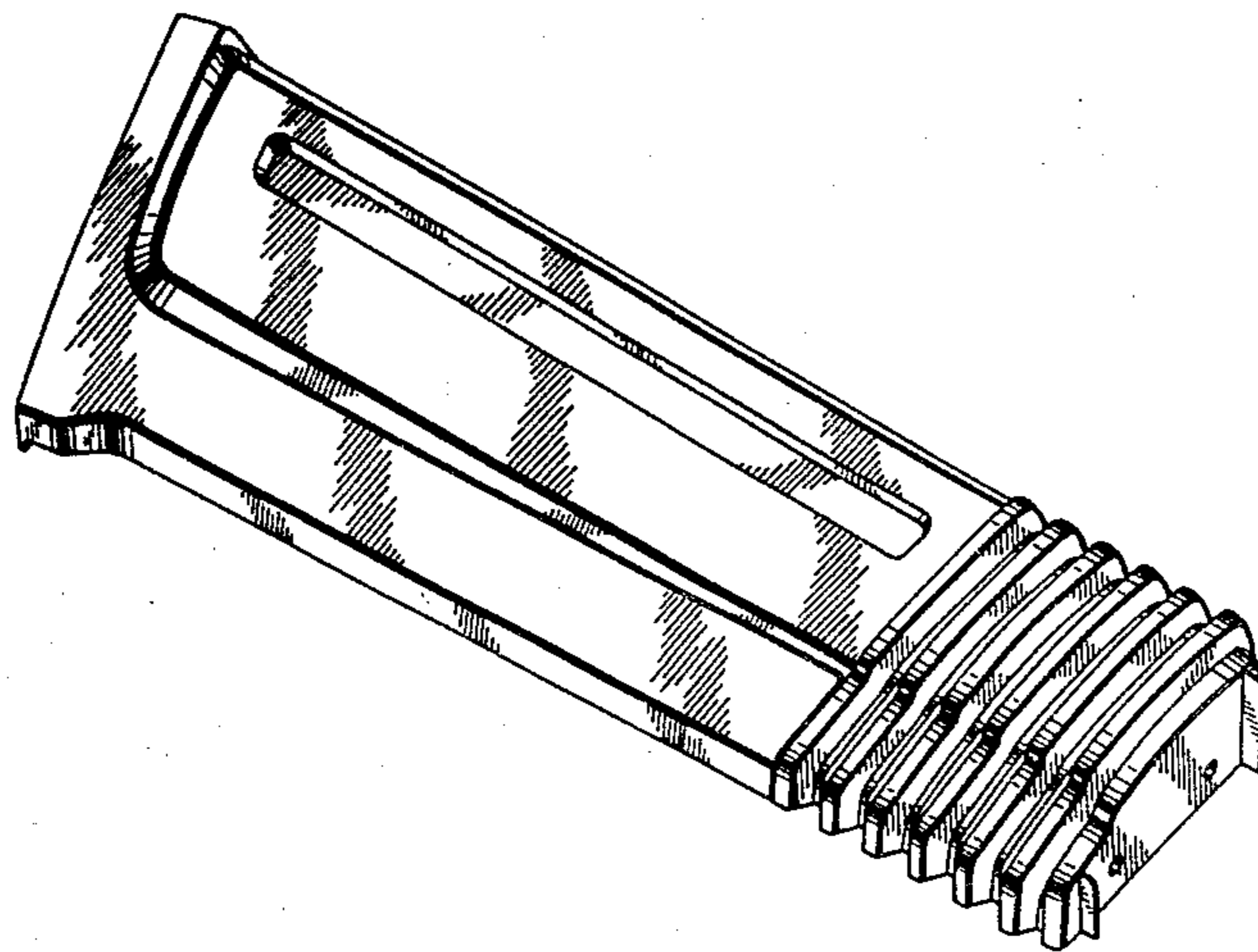

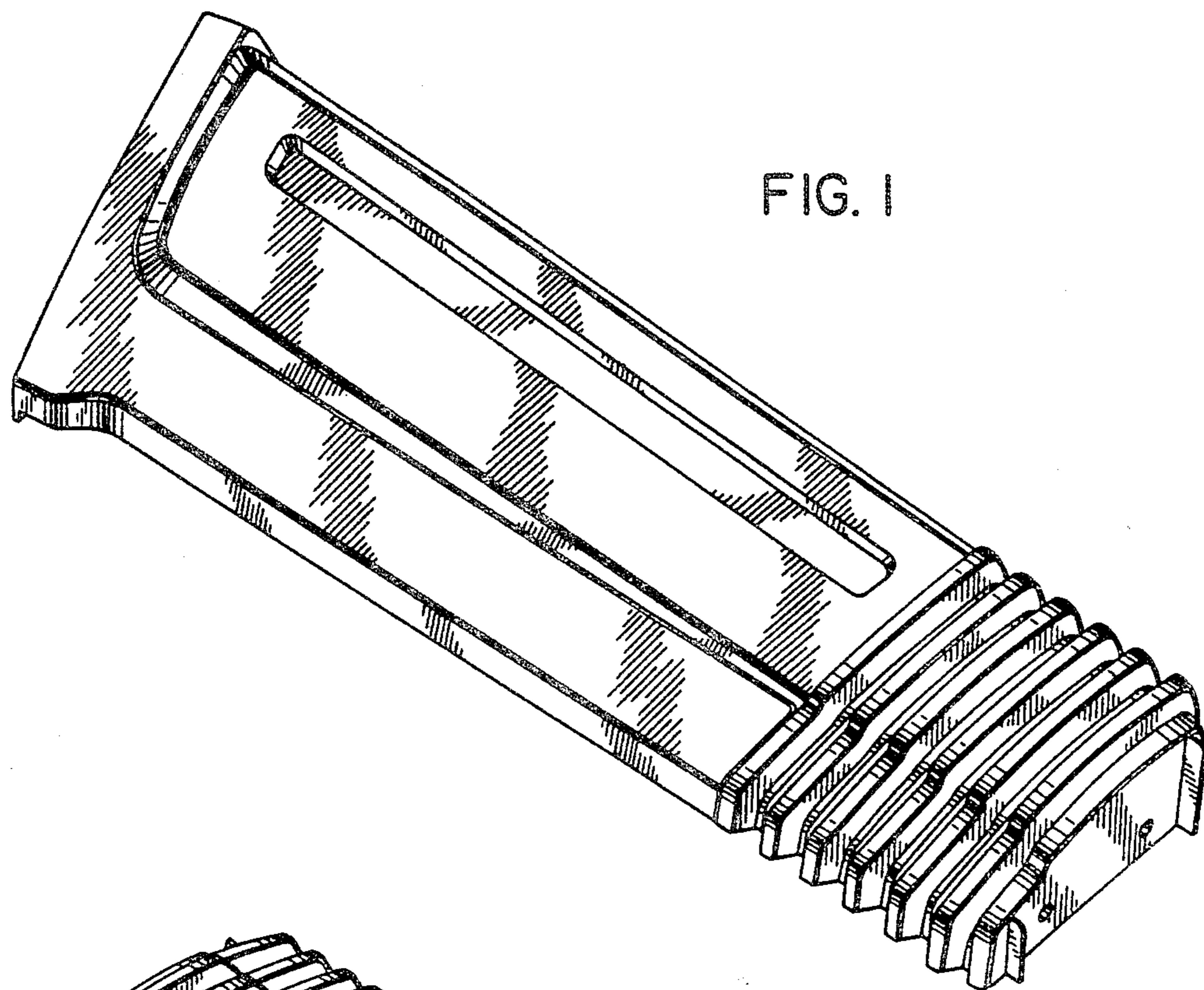

FIG. 1

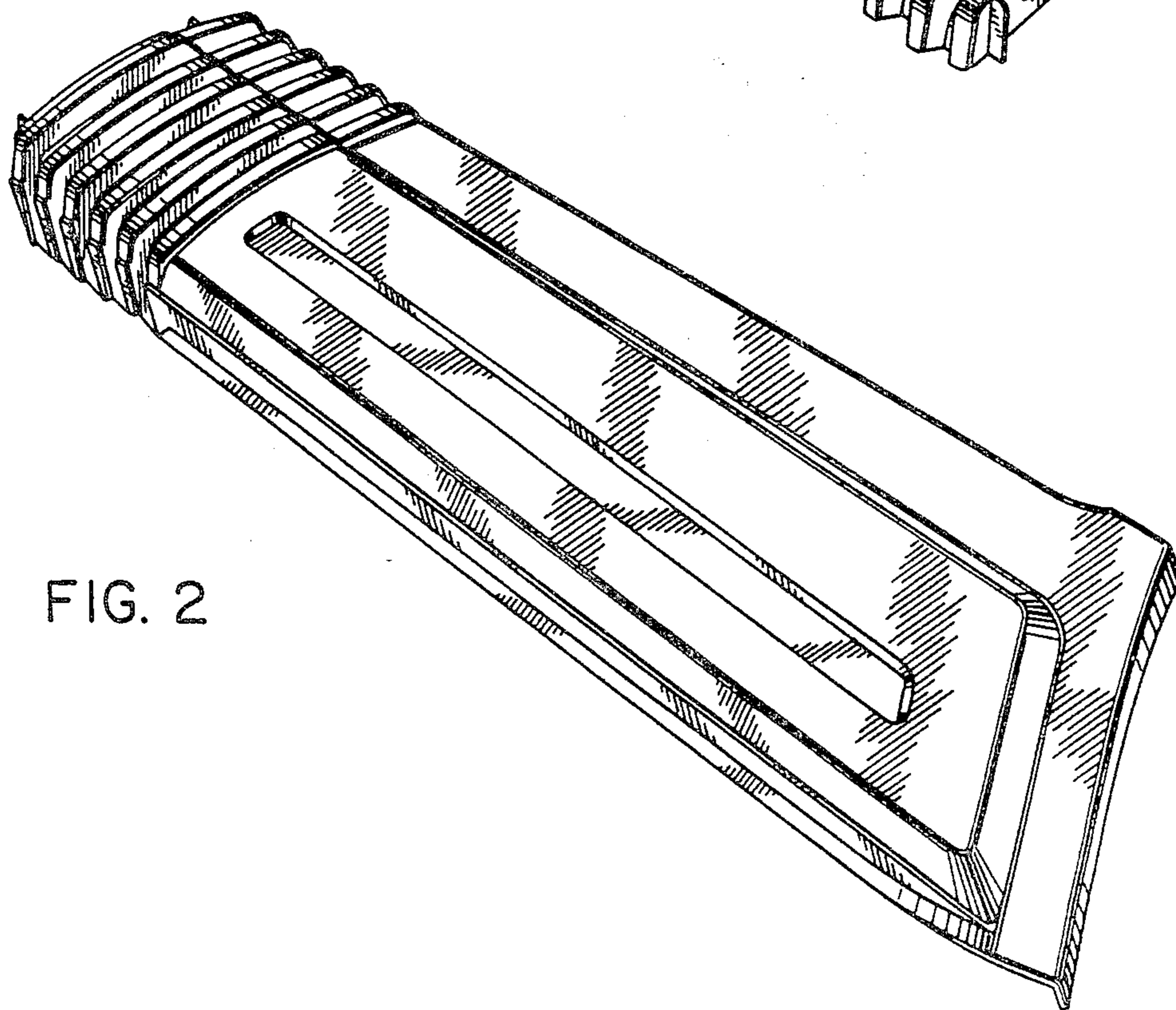

FIG. 2

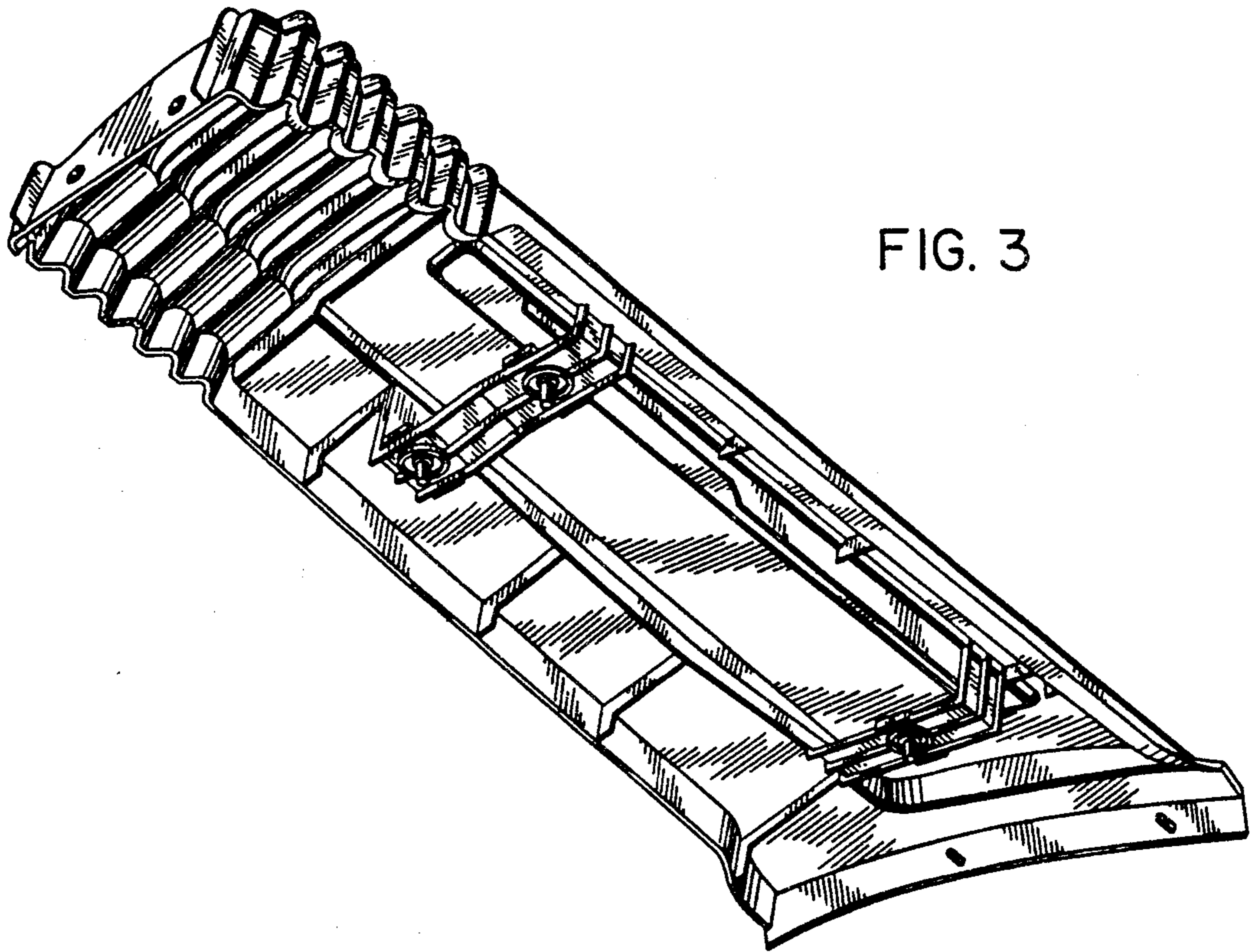

FIG. 3

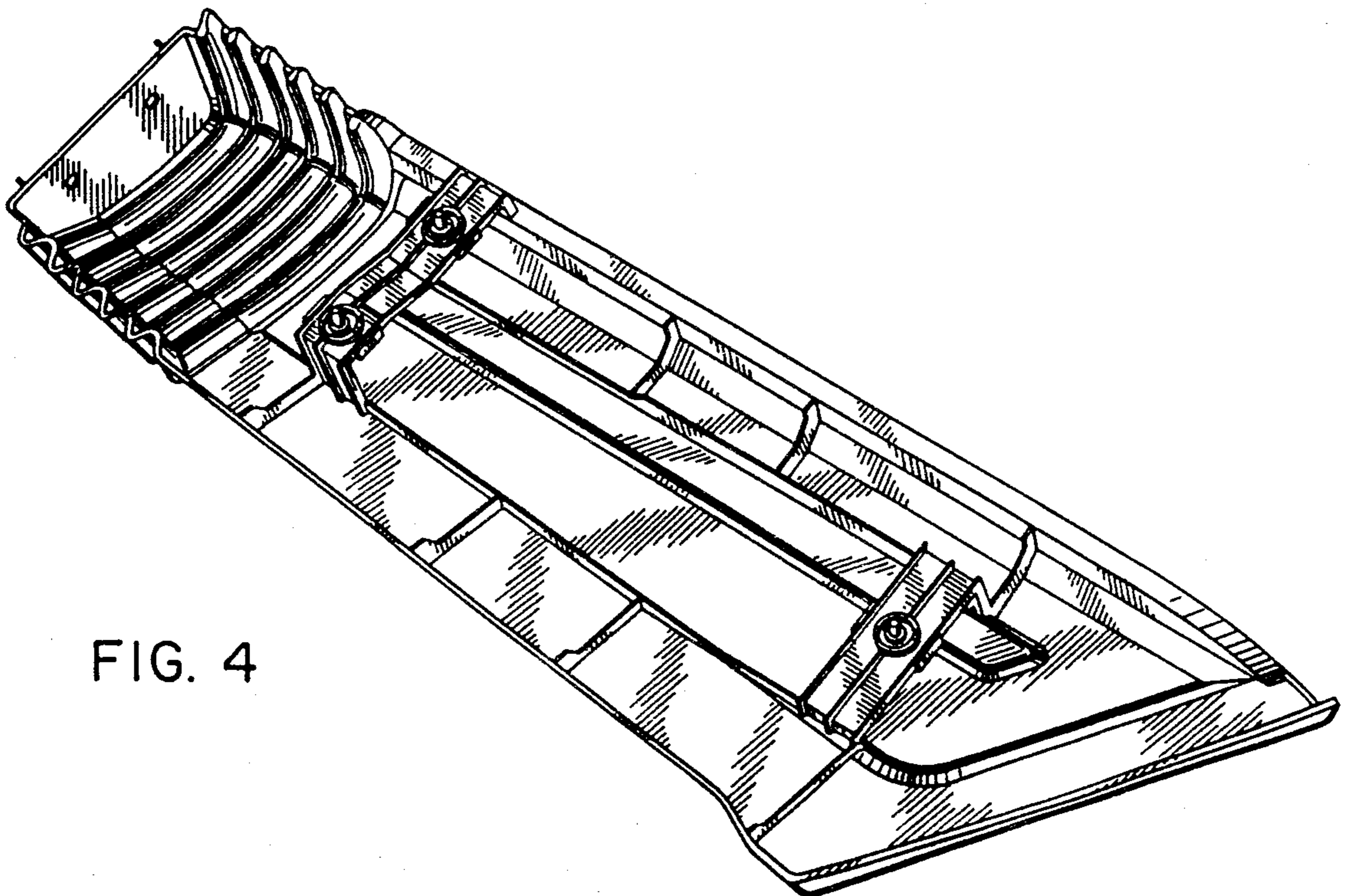

FIG. 4