

[54] MOTORCYCLE SIDE CAR

[76] Inventor: James A. Sontag, 3620 Angelus St., Glendale, Calif. 91208

[**] Term: 14 Years

[21] Appl. No.: 369,158

[22] Filed: Apr. 19, 1982

[52] U.S. Cl. D12/116

[58] Field of Search D12/116; 280/203

[56] References Cited

U.S. PATENT DOCUMENTS

D. 243,597 3/1977 Headington, Jr. D12/116

D. 272,997 3/1984 Anderson et al. D12/116

Primary Examiner—James M. Gandy
Attorney, Agent, or Firm—Jack C. Munro

[57] CLAIM

The ornamental design for a motorcycle side car, as shown and described.

DESCRIPTION

FIG. 1 is a perspective view of the motorcycle side car showing my new design;
FIG. 2 is a right side elevational view thereof;
FIG. 3 is a left side elevational view thereof;
FIG. 4 is a top, plan view thereof;
FIG. 5 is a front, elevational view thereof;
FIG. 6 is a rear, elevational view thereof;
FIG. 7 is a bottom, plan view thereof;
FIG. 8 is a perspective view thereof in open position for use as a camper;
FIG. 9 is a right, side elevational view of FIG. 8;
FIG. 10 is a left side elevational view of FIG. 8;
FIG. 11 is a front, elevational view of FIG. 8; and
FIG. 12 is a rear, elevational view of FIG. 8.

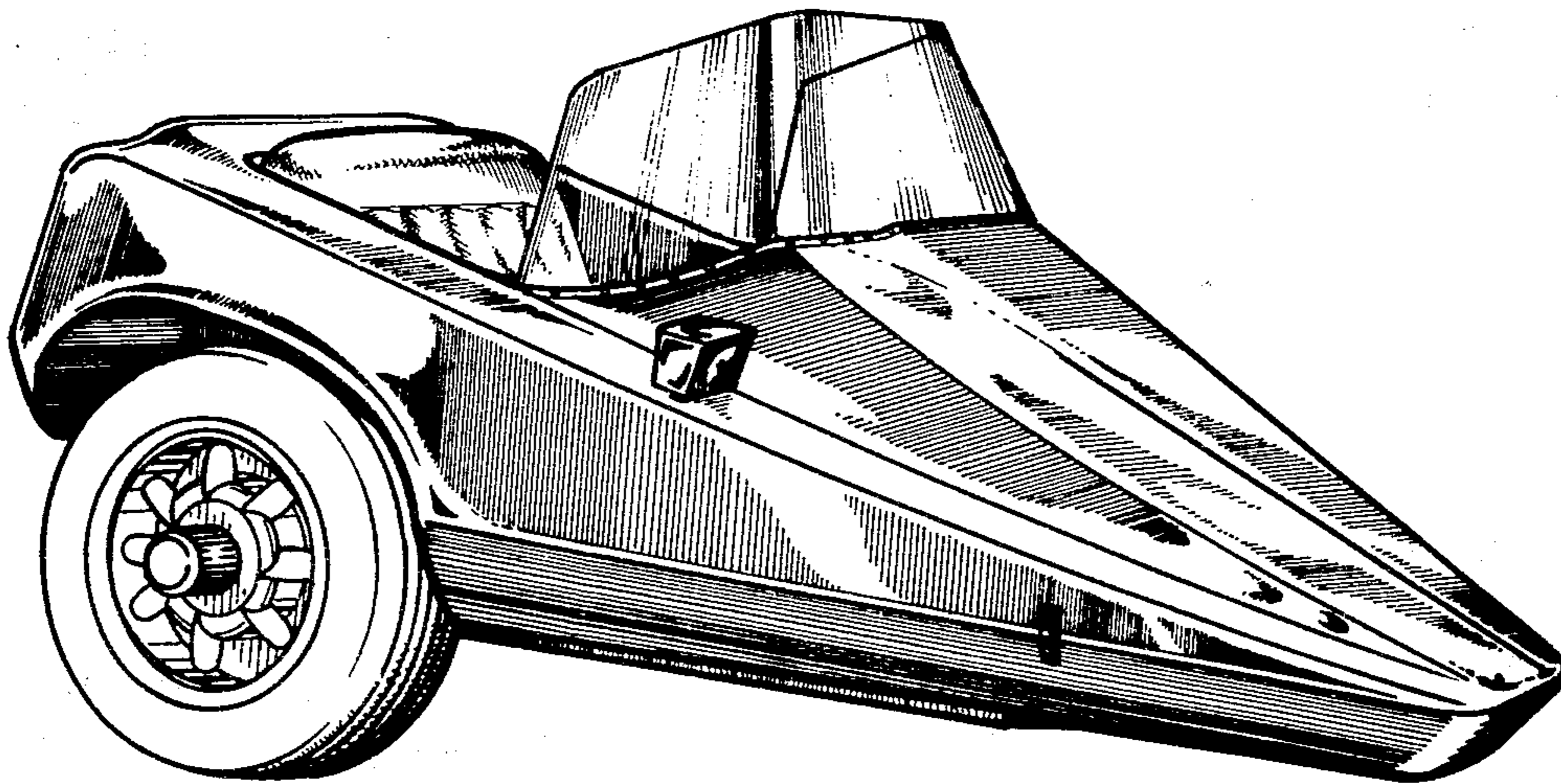

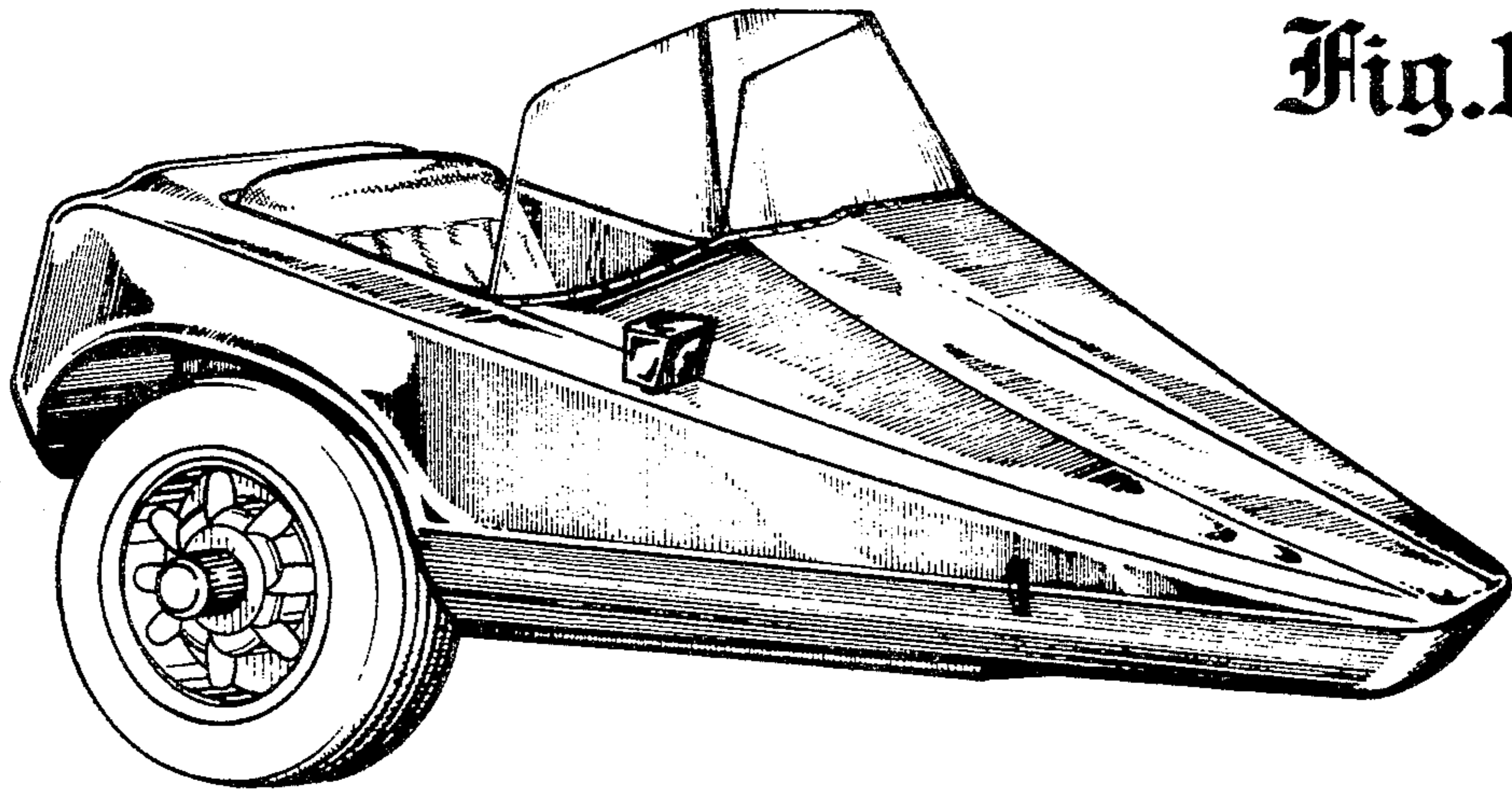

Fig. 1.

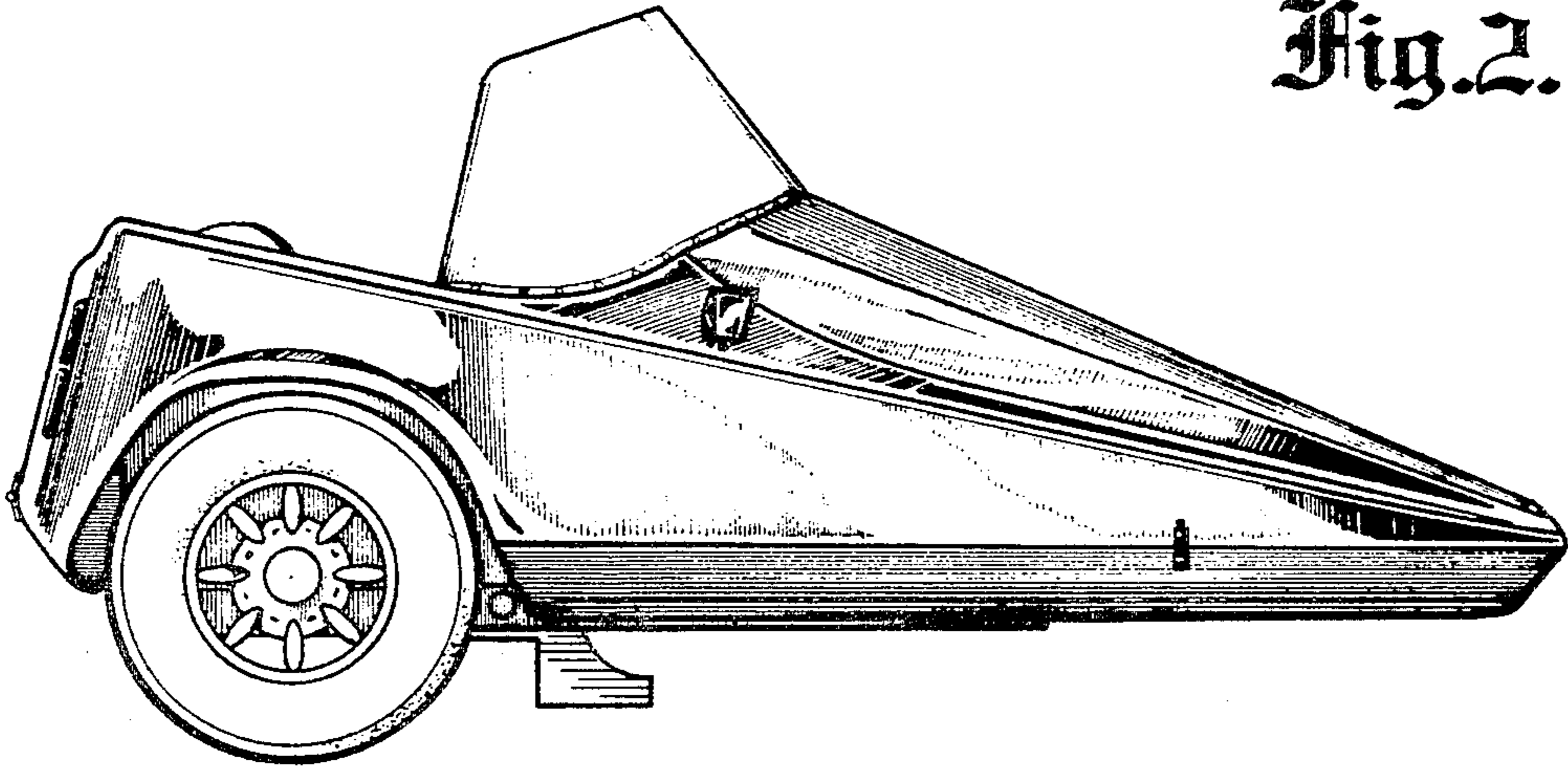

Fig. 2.

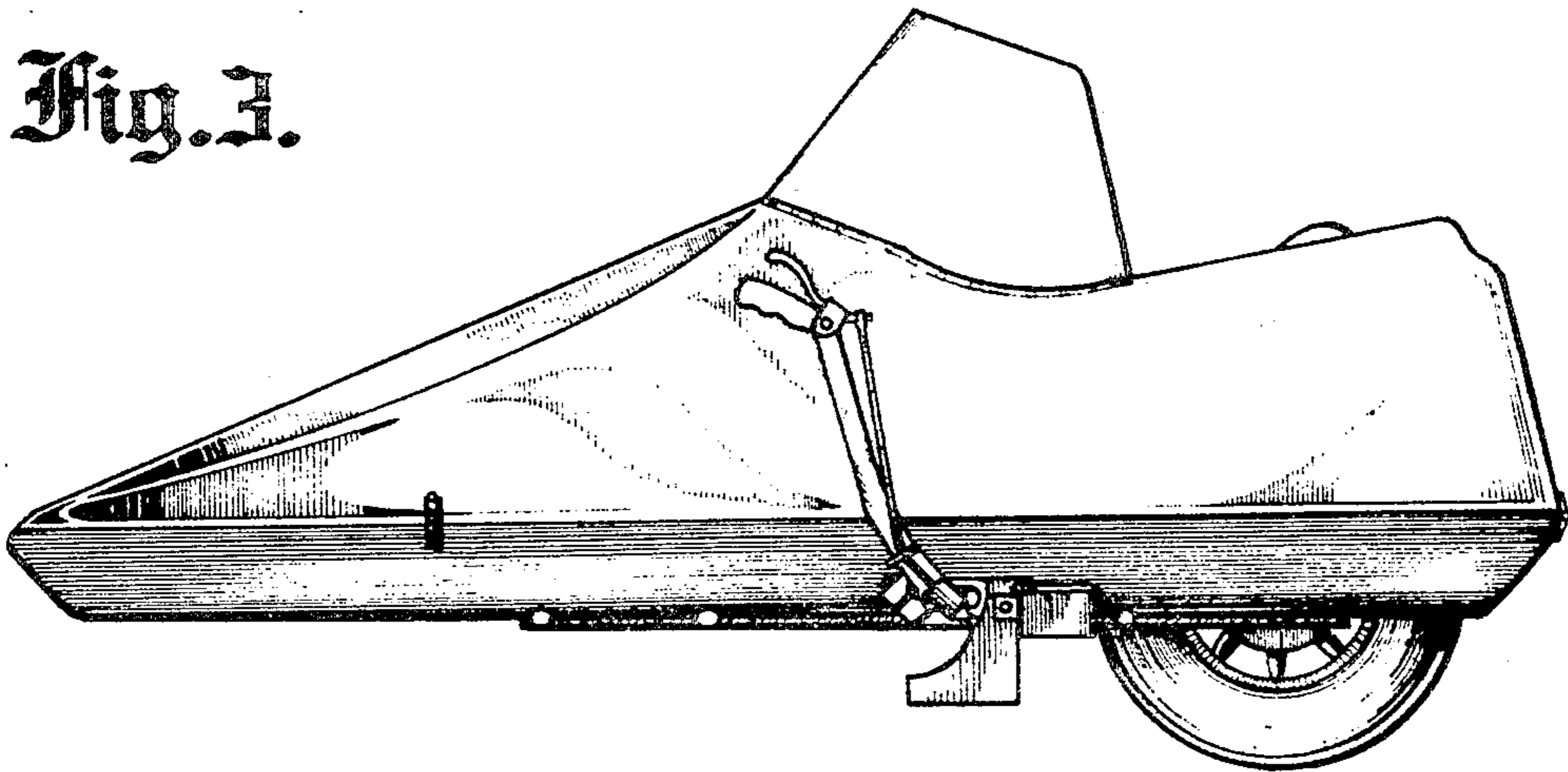

Fig. 3.

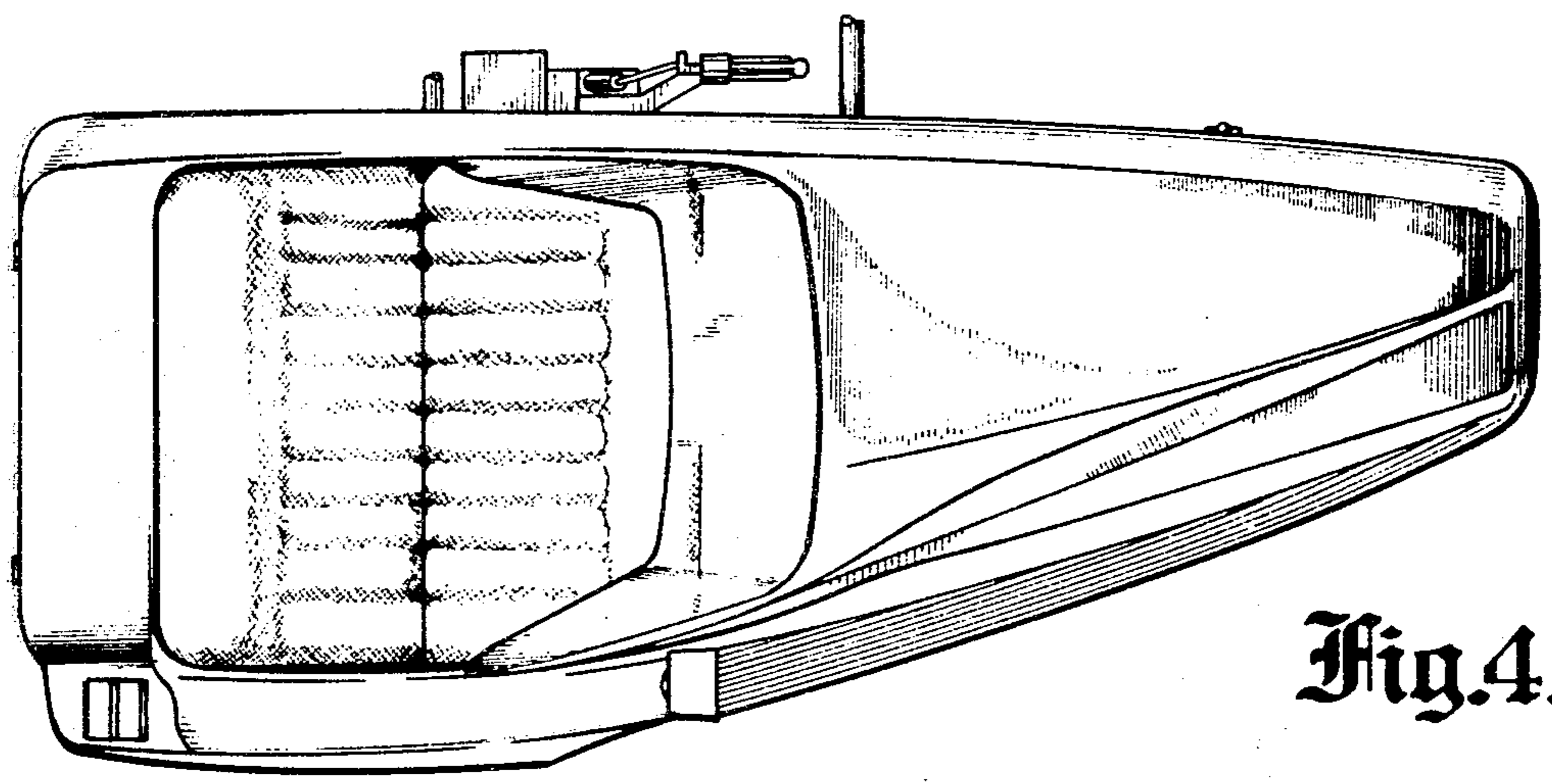

Fig. 4.

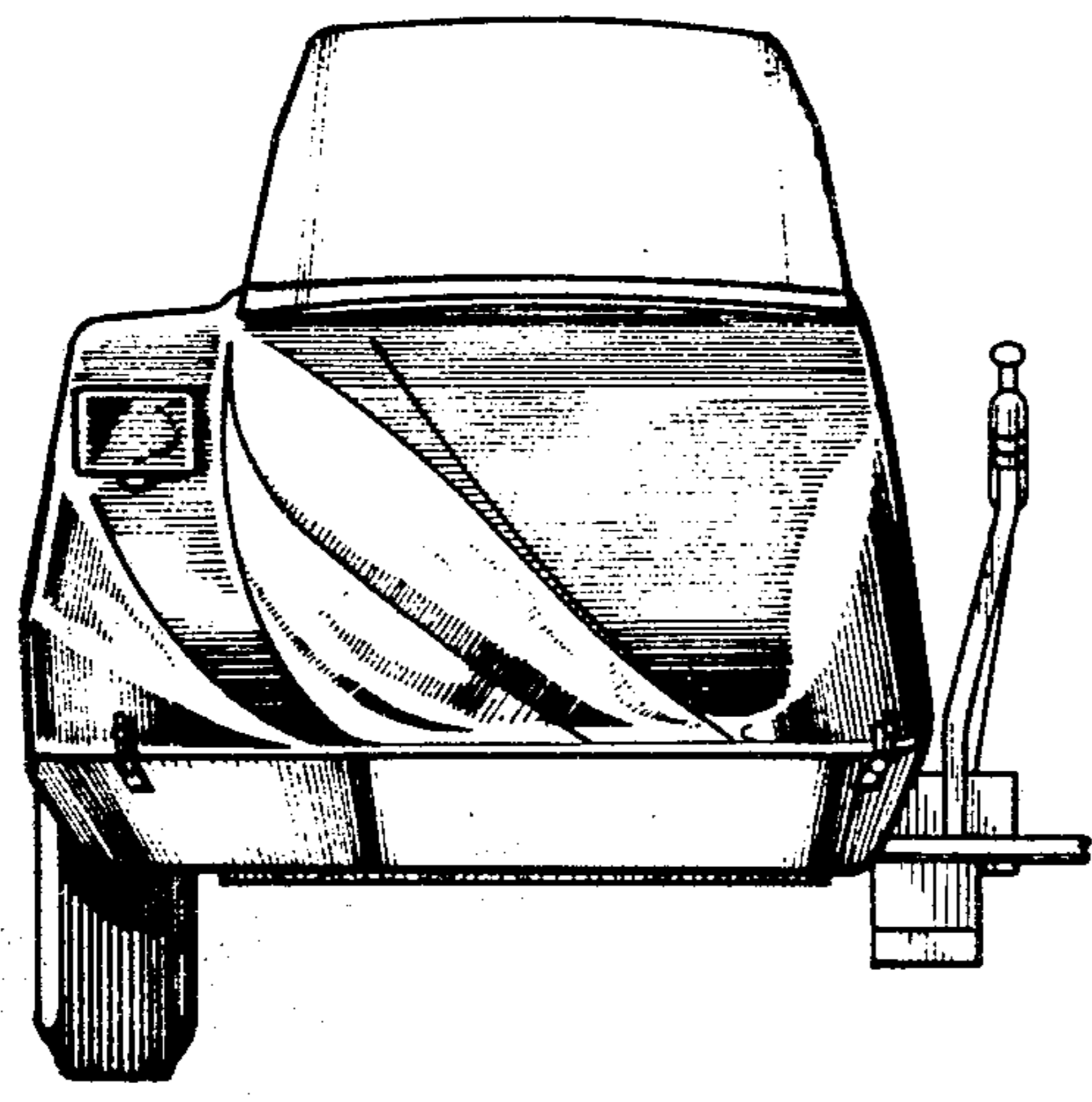

Fig. 5.

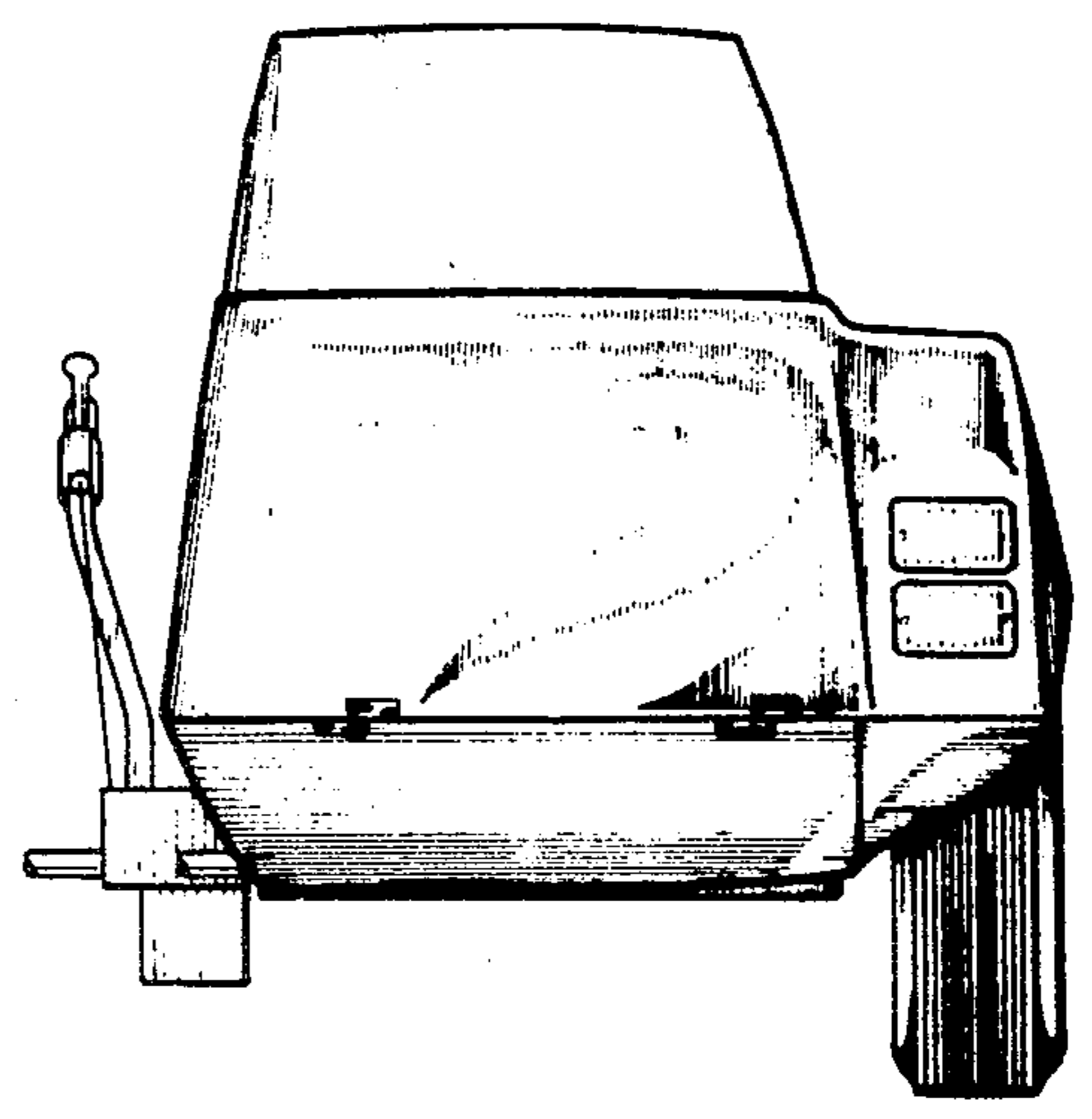

Fig. 6.

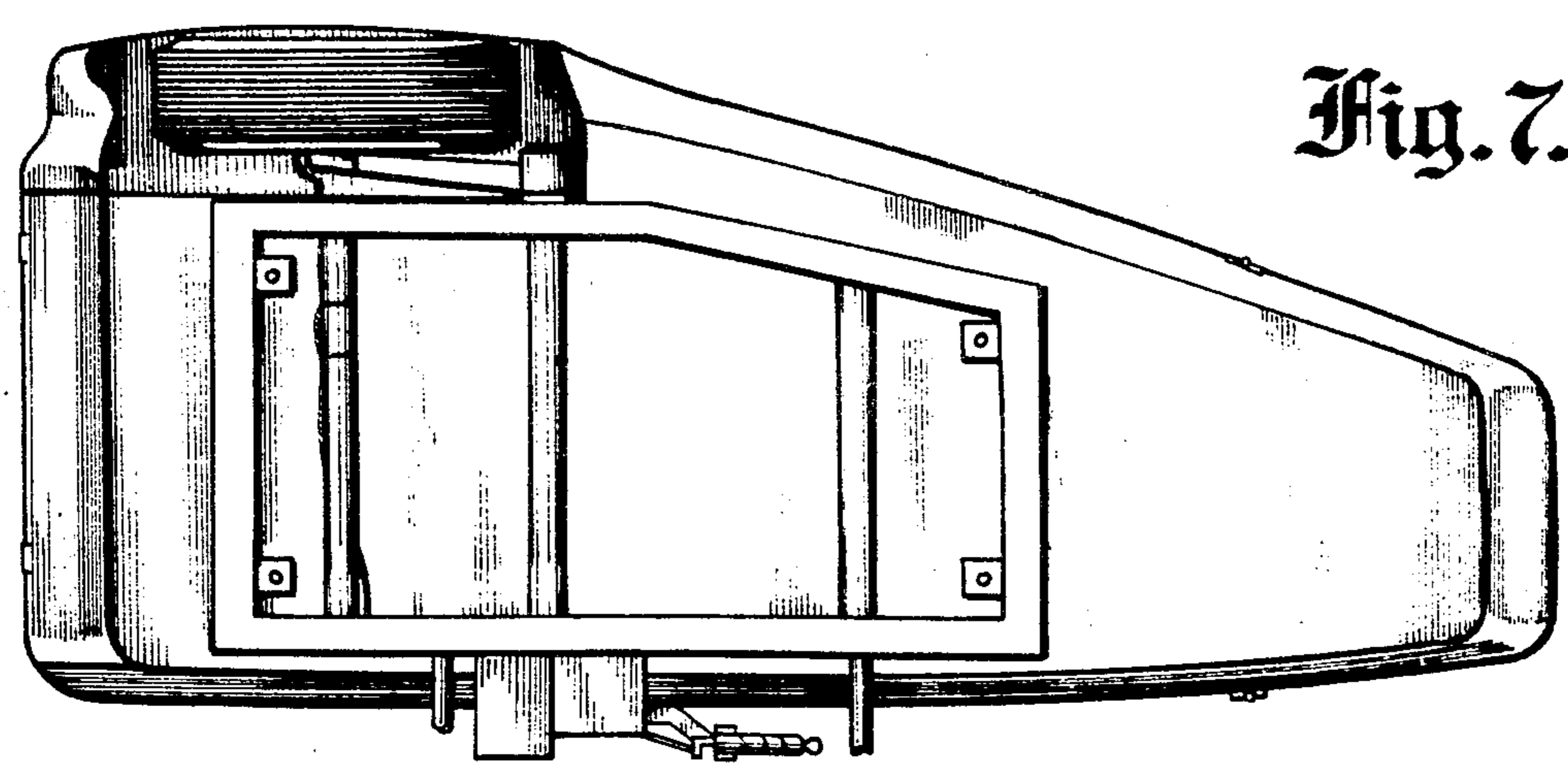

Fig. 7.

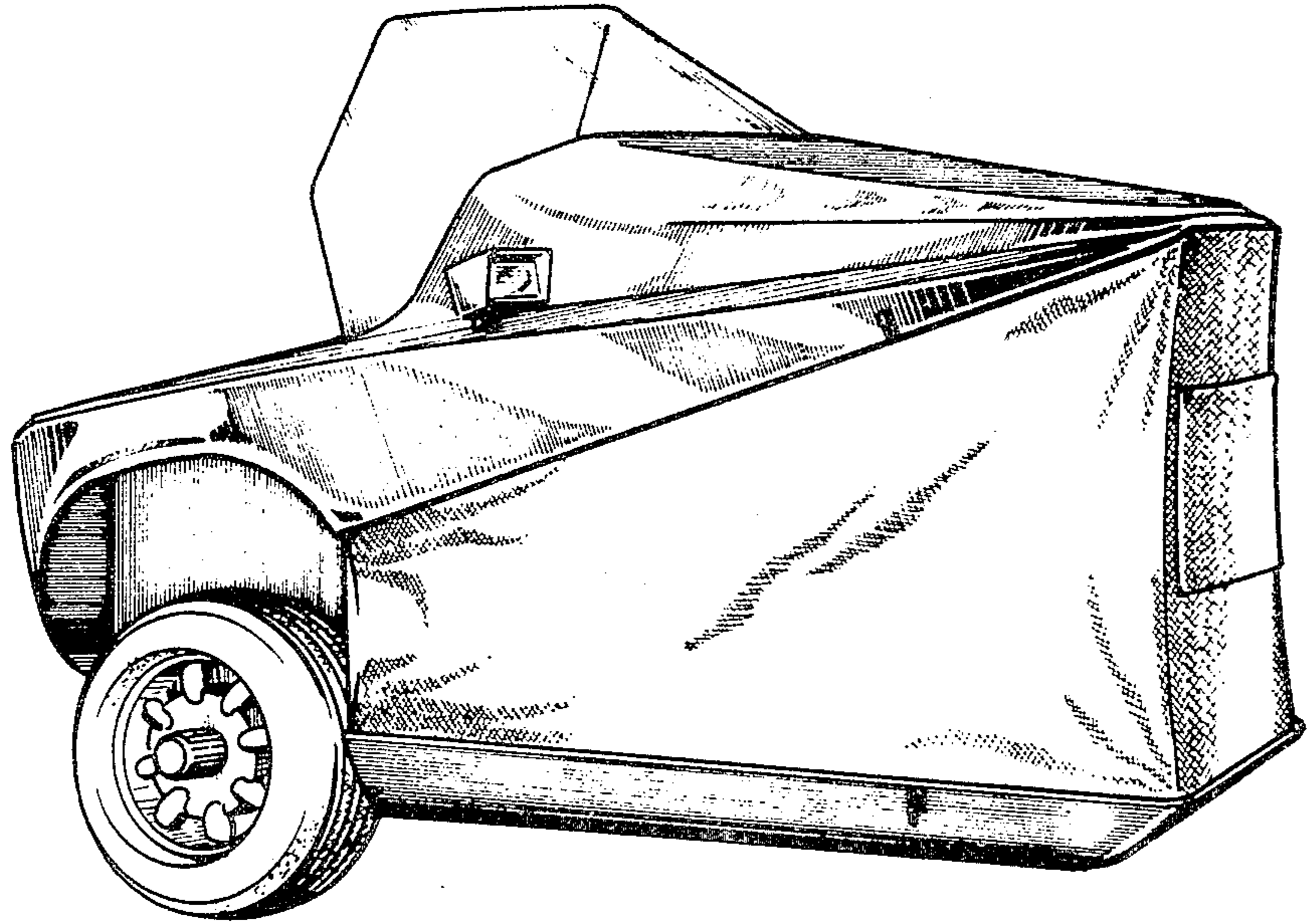
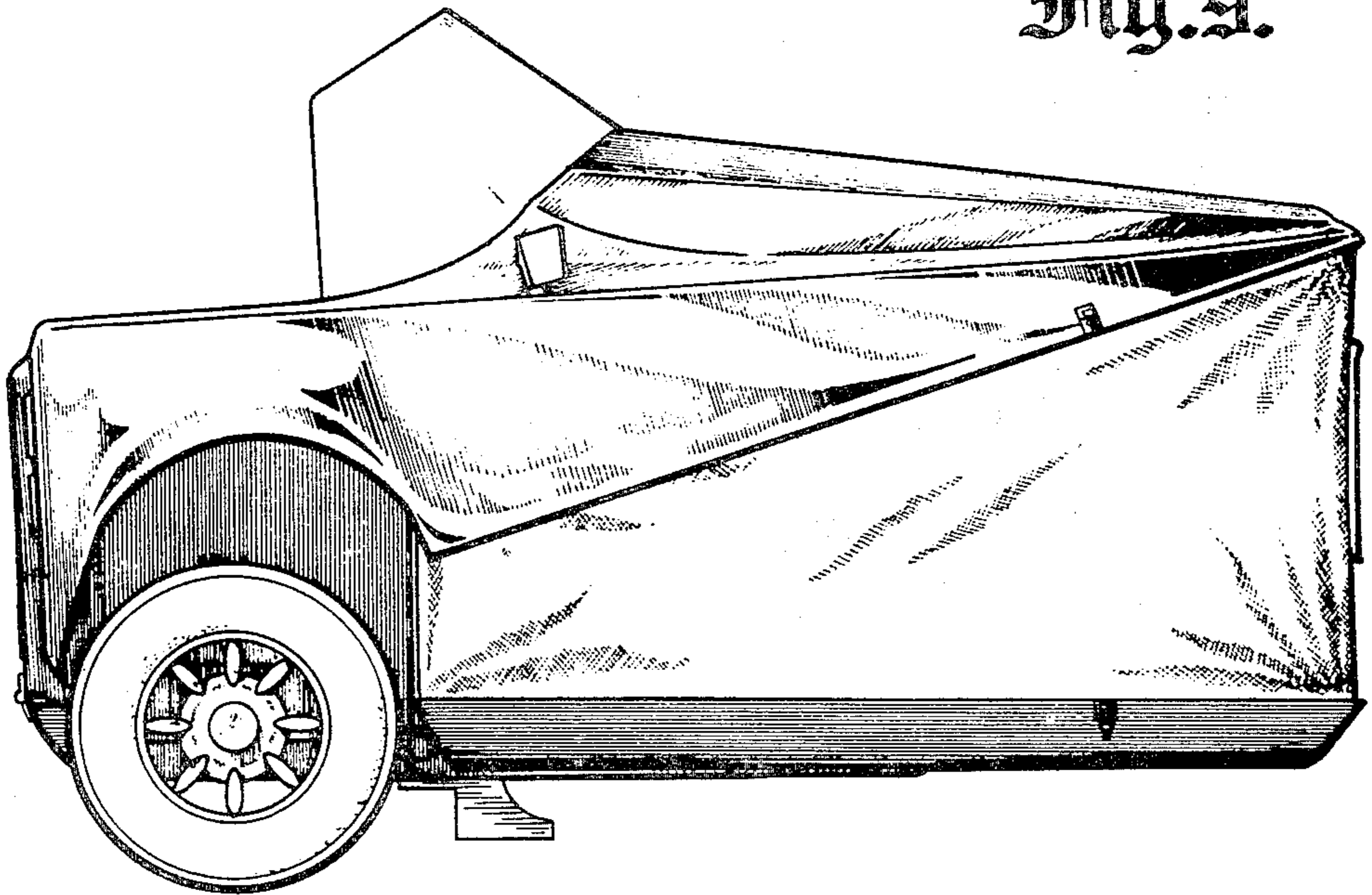

Fig. 8.

Fig. 9.



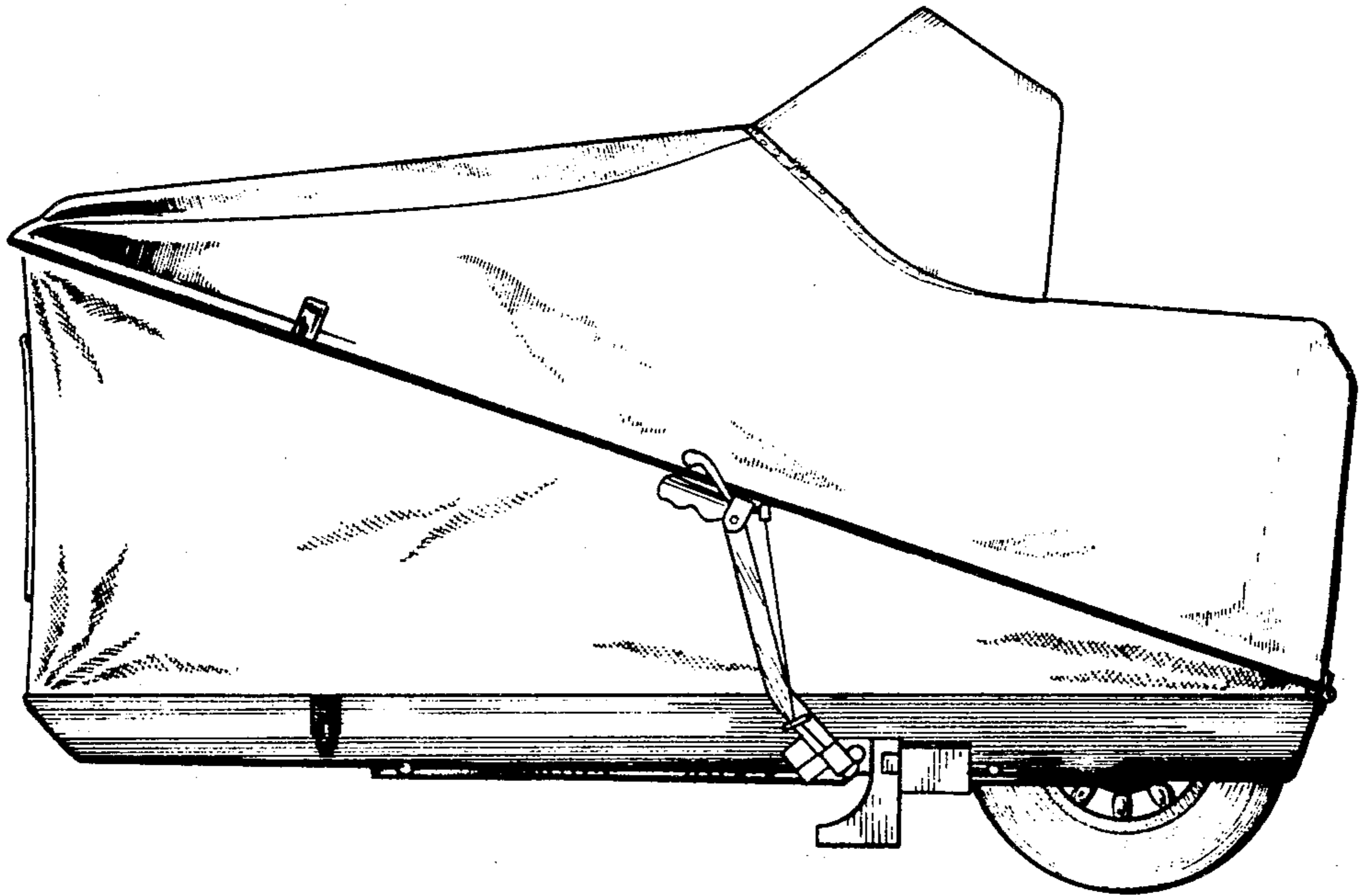

Fig. 10.

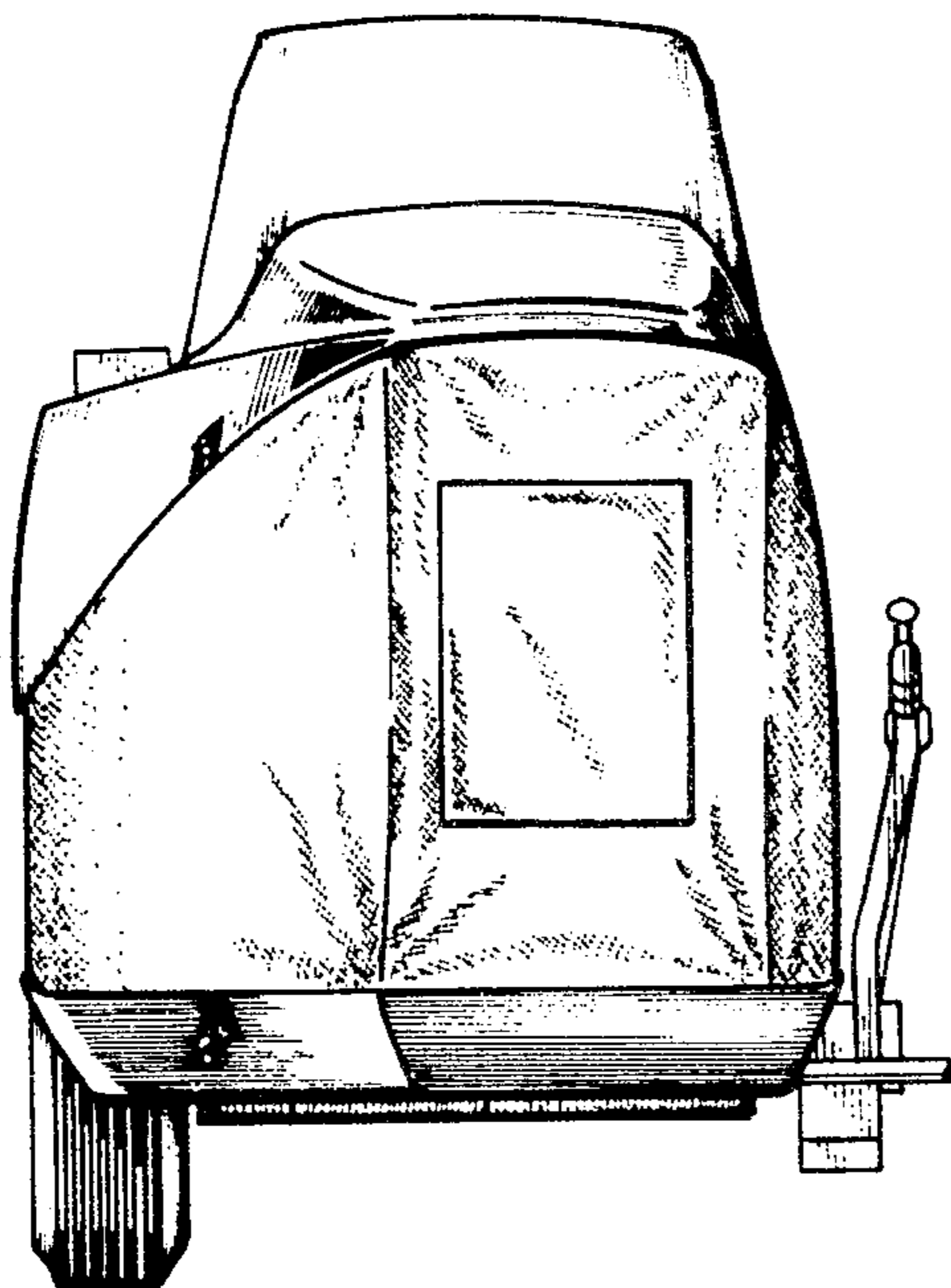

Fig. 11.

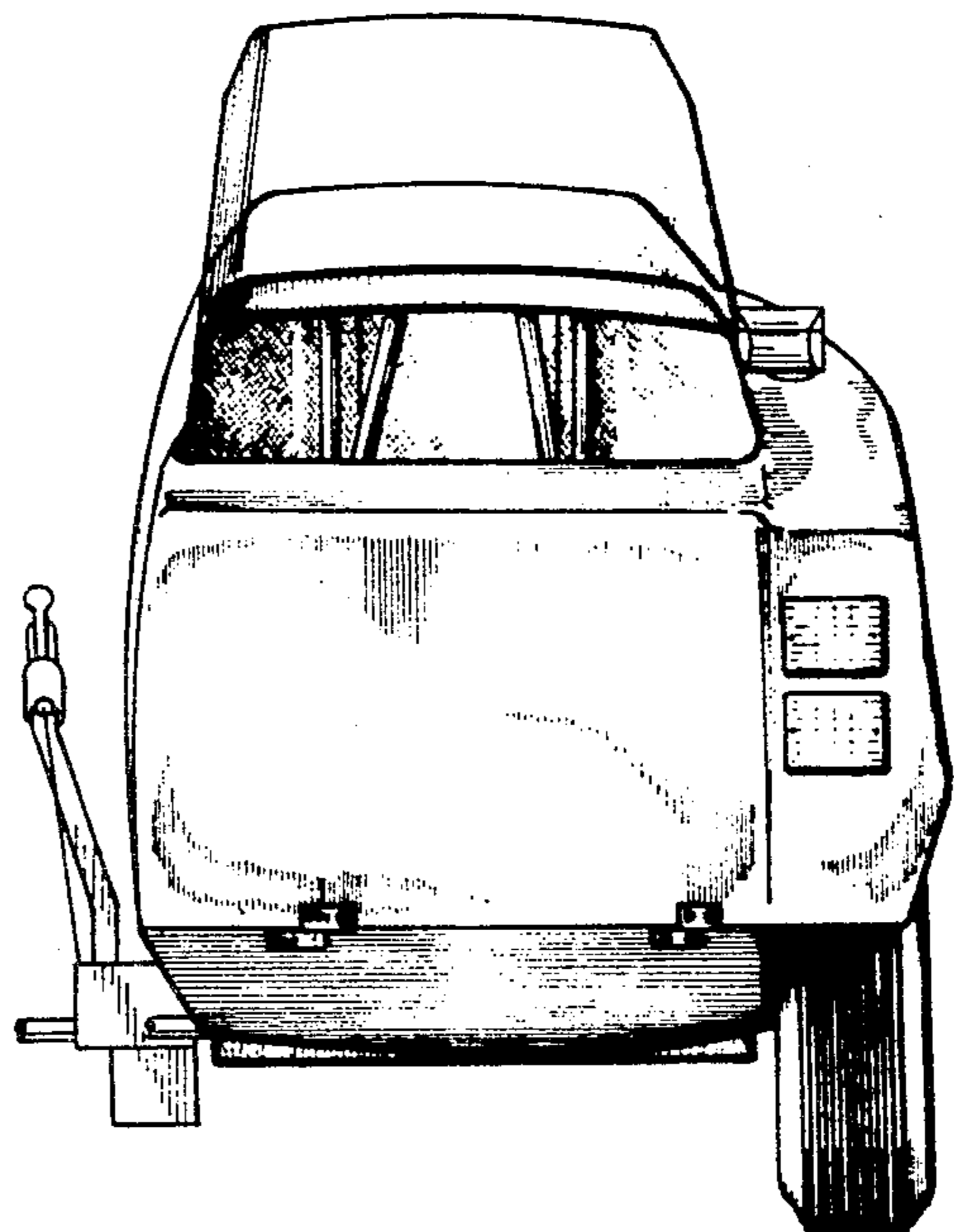

Fig. 12.