

# United States Patent [19]

Druecker et al.

[11] Patent Number: **Des. 280,315**

[45] Date of Patent: **\*\* Aug. 27, 1985**

[54] **MOTORCYCLE LUGGAGE CARRIER**

4,440,330 4/1984 Goodman ..... 224/32 A

[75] Inventors: **Mark T. Druecker, Glendale; Ty S. Bowers, Phoenix, both of Ariz.**

*Primary Examiner*—James M. Gandy  
*Attorney, Agent, or Firm*—Gregory J. Nelson

[73] Assignee: **Daystar, Inc., Glendale, Ariz.**

[57] **CLAIM**

[\*\*] Term: **14 Years**

The ornamental design for a motorcycle luggage carrier, as shown.

[21] Appl. No.: **480,904**

[22] Filed: **Mar. 31, 1983**

[52] U.S. Cl. .... **D12/158**

[58] Field of Search ..... **D12/158; 224/32 A, 39**

**DESCRIPTION**

FIG. 1 is a perspective view of a motorcycle luggage carrier showing our new design;  
FIG. 2 is a front elevational view thereof;  
FIG. 3 is a rear elevational view thereof;  
FIG. 4 is a top plan view thereof;  
FIG. 5 is a bottom plan view thereof; and  
FIG. 6 is a side elevational view thereof.

[56] **References Cited**

**U.S. PATENT DOCUMENTS**

4,311,261 1/1982 Anderson et al. .... 224/32 A

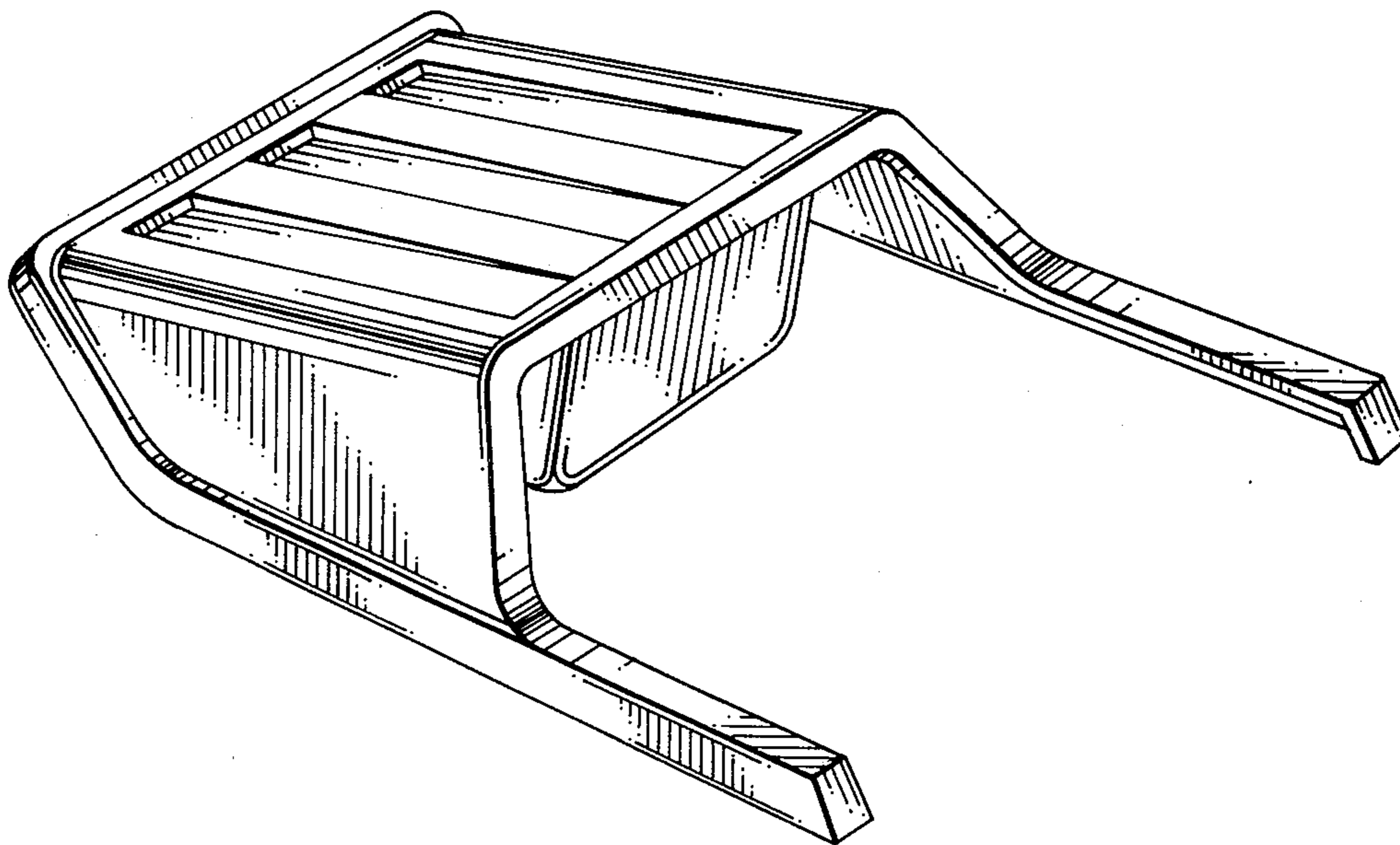

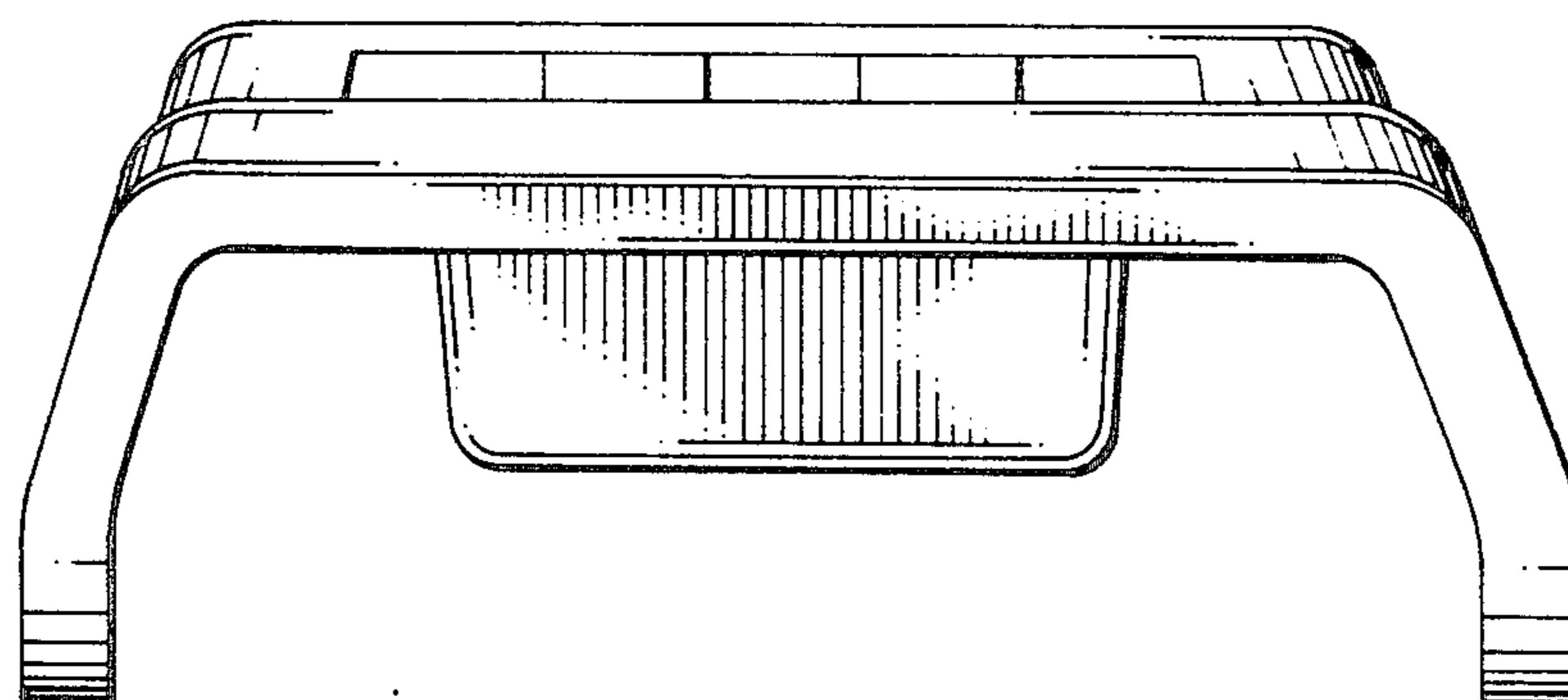
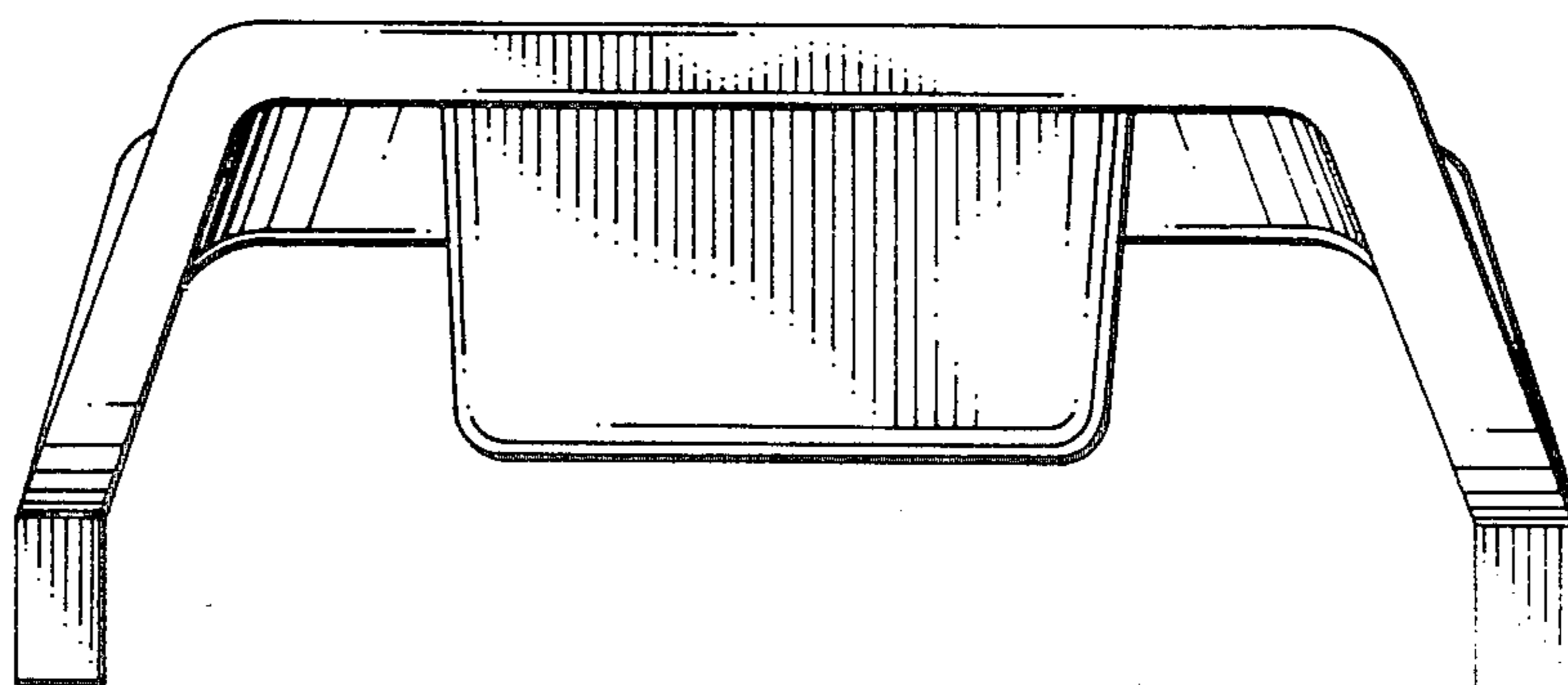
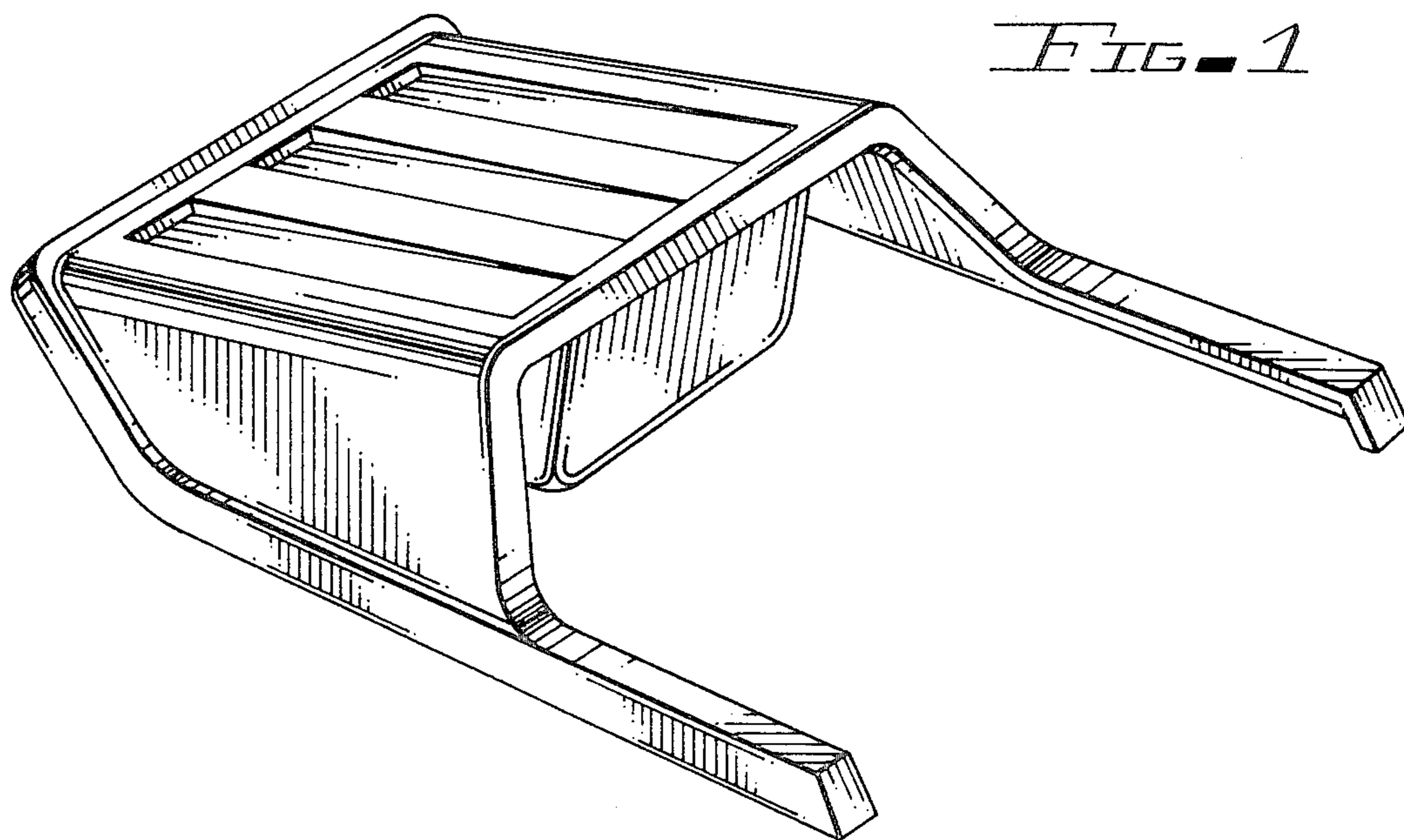

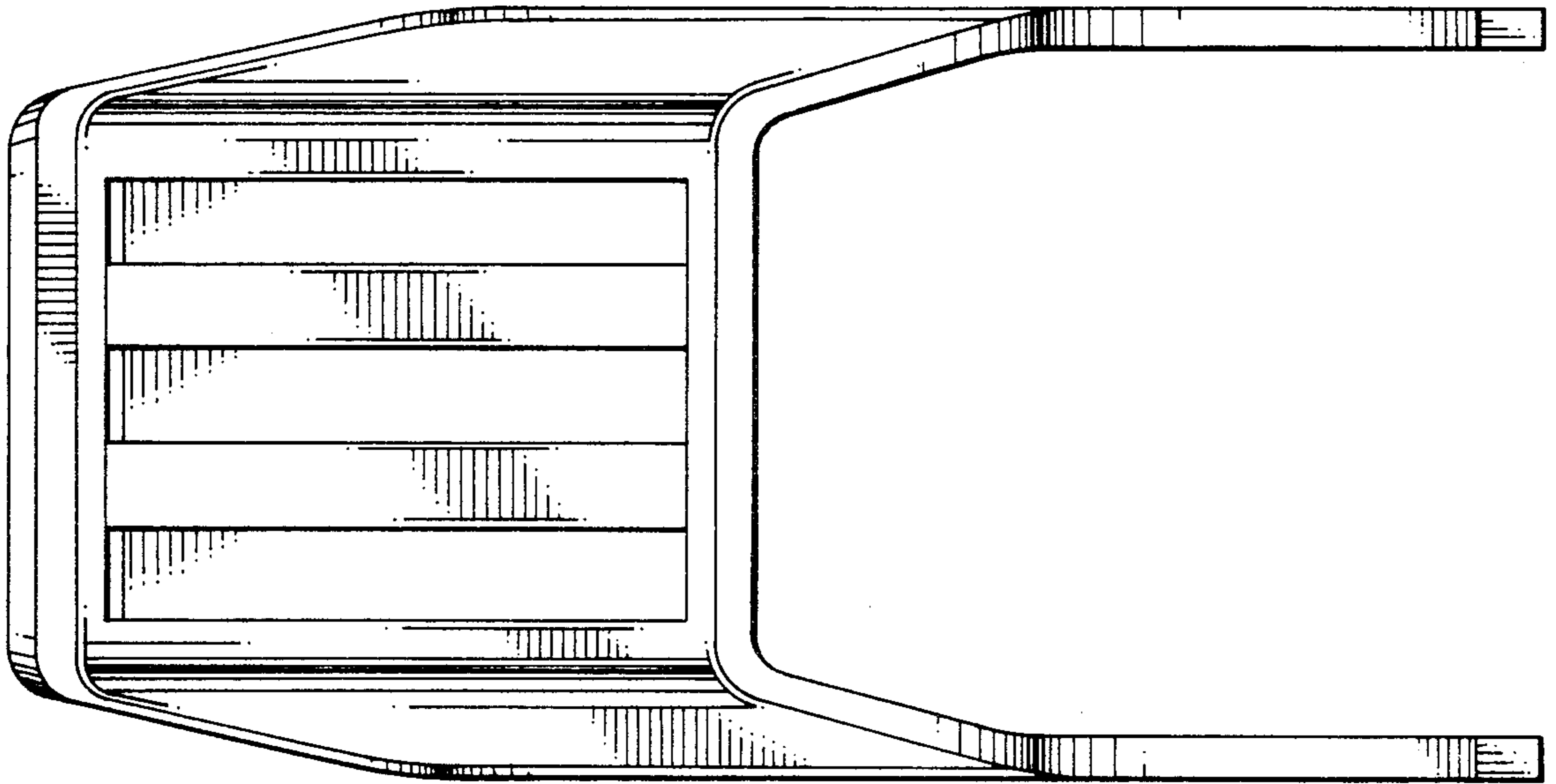

FIG. 4

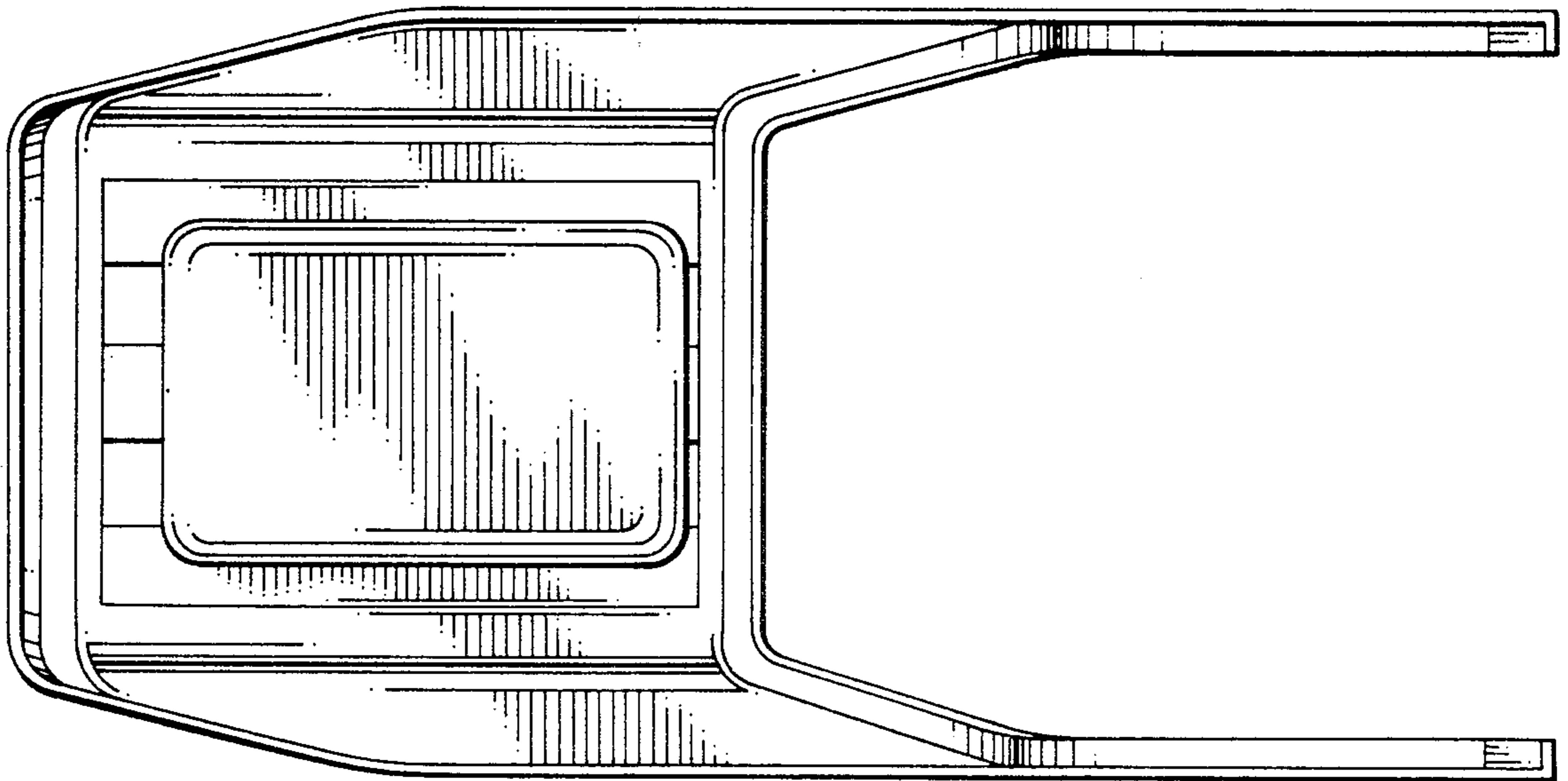

FIG. 5

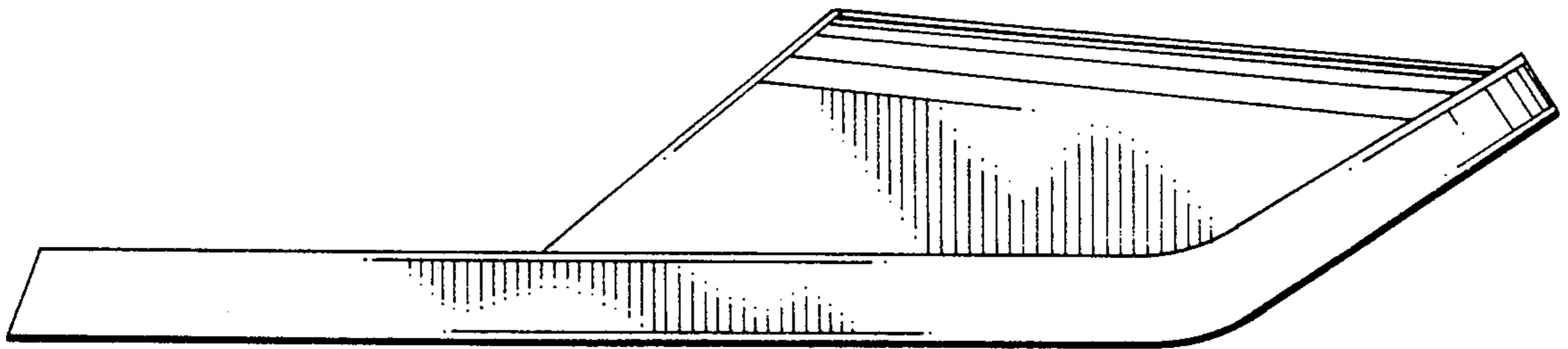

FIG. 6