

[54] AUTOMOBILE ALARM

| | | | |
|-----------|--------|--------|--------|
| 3,566,350 | 2/1971 | Kahn | 340/65 |
| 4,211,995 | 7/1980 | Smith | 340/63 |
| 4,322,714 | 3/1982 | Morgan | 340/65 |

[76] Inventor: Terry T. Kunimune, 6058 San Fernando Rd., Glendale, Calif. 91202

Primary Examiner—B. J. Bullock
Assistant Examiner—Suzanne N. Gitlin
Attorney, Agent, or Firm—Erik M. Arnheim

[**] Term: 14 Years

[21] Appl. No.: 517,217

[57] CLAIM

[22] Filed: Jul. 25, 1983

The ornamental design for an automobile alarm, as substantially shown.

[52] U.S. Cl. D10/106

[58] Field of Search D10/104, 106, 121;
340/63, 64, 65, 693

DESCRIPTION

[56] References Cited

U.S. PATENT DOCUMENTS

| | | | |
|------------|--------|----------|---------|
| D. 194,976 | 4/1963 | Waytena | D10/104 |
| D. 218,439 | 8/1970 | Horowitz | D10/100 |
| 3,513,466 | 5/1970 | Isaacs | 340/64 |

FIG. 1 is a front perspective view of an automobile alarm showing my new design;
FIG. 2 is a rear elevational view thereof;
FIG. 3 is a bottom plan view thereof;
FIG. 4 is a side elevational view thereof, the opposite side being a mirror image.

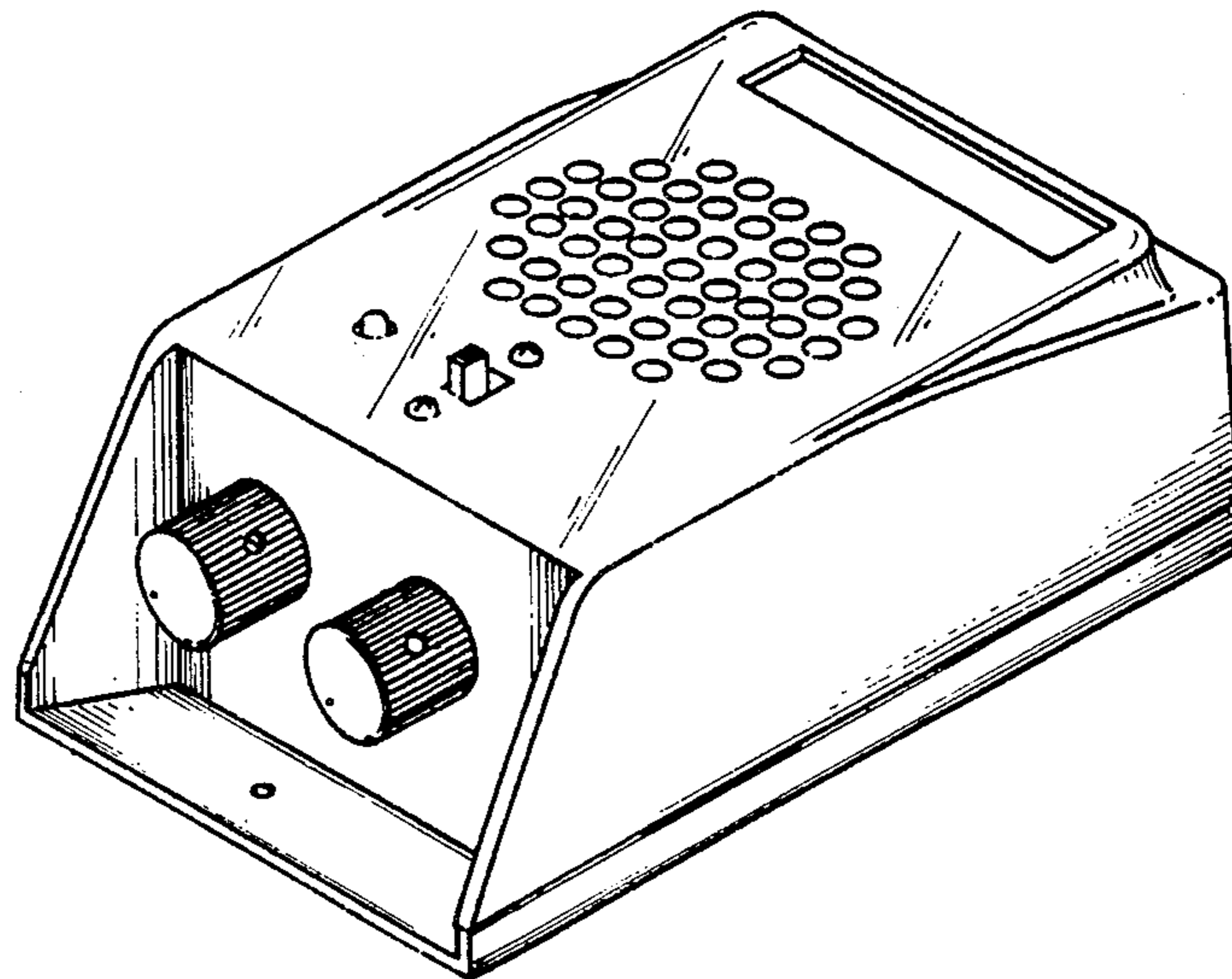

FIG. 1

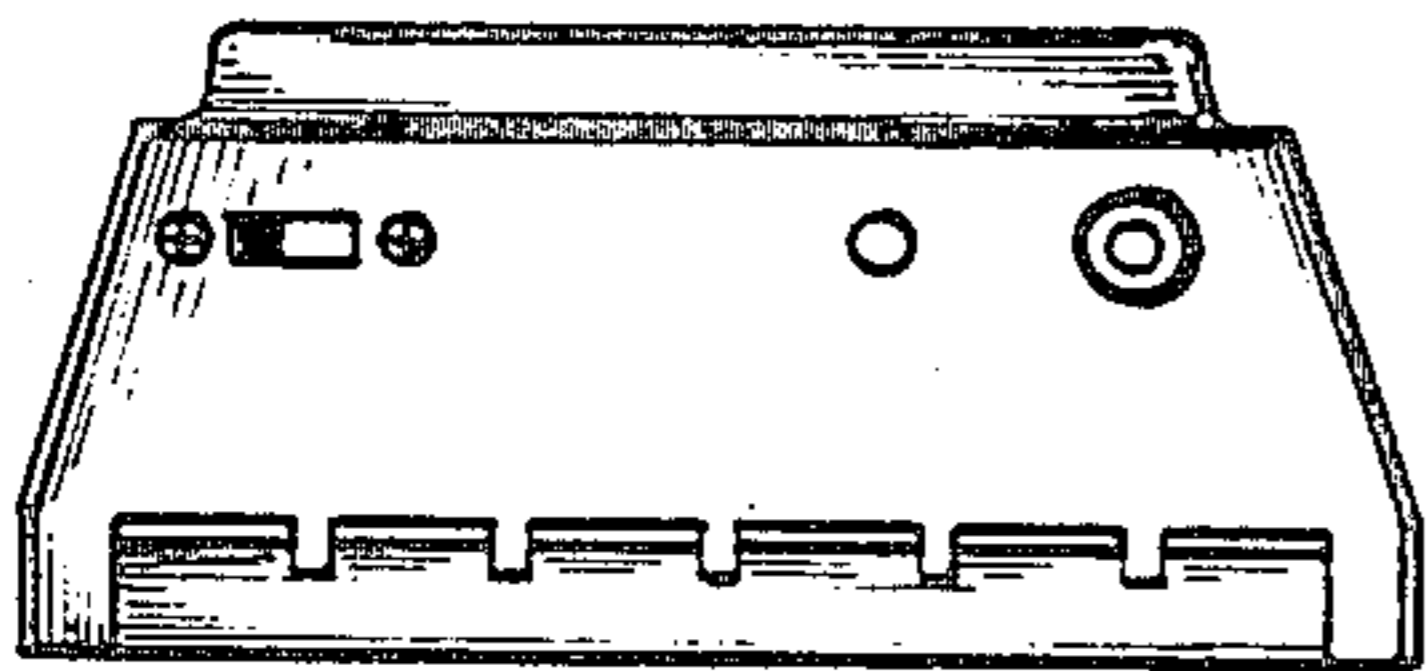
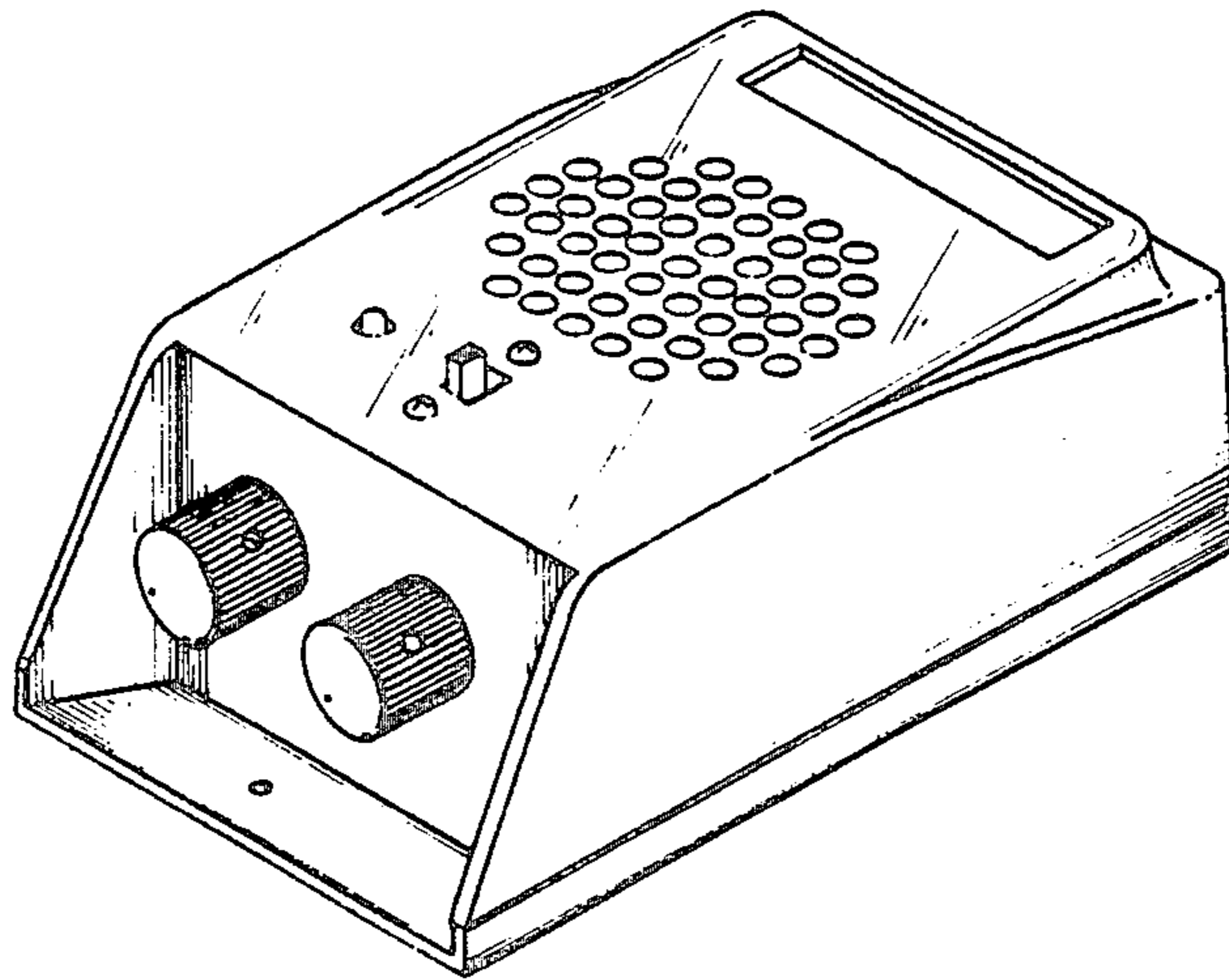

FIG. 2

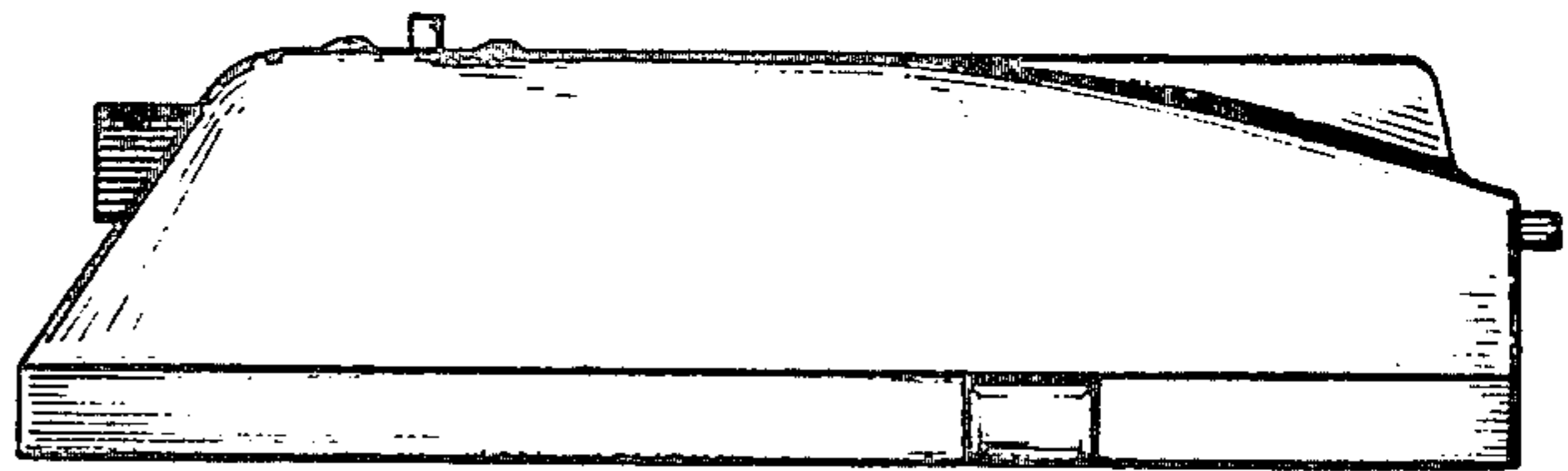

FIG. 4

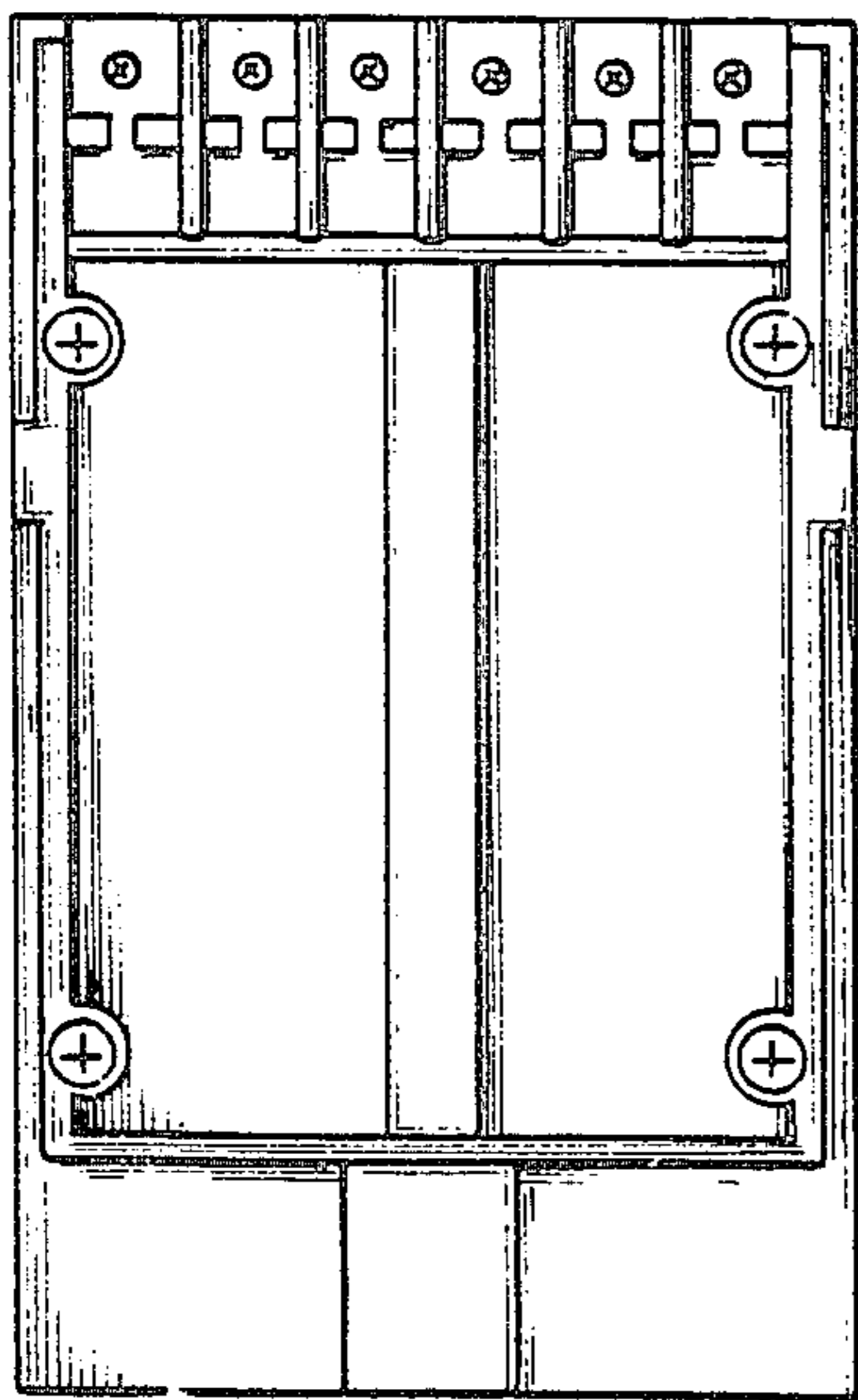

FIG. 3