

[54] CALIPER

[75] Inventors: Shingo Nishina, Kawasaki; Takashi Kobashi, Utsunomiya, both of Japan

[73] Assignee: Mitutoyo Mfg. Co., Ltd., Tokyo, Japan

[**] Term: 14 Years

[21] Appl. No.: 485,543

[22] Filed: Apr. 15, 1983

[30] Foreign Application Priority Data

Oct. 27, 1982 [JP] Japan 57-48811

[52] U.S. Cl. D10/73

[58] Field of Search D10/73; 33/143 R, 147 R, 33/147 J, 147 N, 147 T, 143 L

[56] References Cited

U.S. PATENT DOCUMENTS

- D. 233,787 11/1974 Uchino D10/73
- D. 235,627 7/1975 Uchino D10/73

- D. 235,628 7/1975 Nishigata D10/73
- D. 255,998 7/1980 Merchant D10/73
- D. 257,009 9/1980 Sibukawa D10/73
- D. 268,739 4/1983 Hampf D10/73
- 3,945,121 3/1976 Uchino 33/147 T

Primary Examiner—Nelson C. Holtje
Attorney, Agent, or Firm—Flynn, Thiel, Boutell & Tanis

[57] CLAIM

The ornamental design for the caliper, as shown.

DESCRIPTION

FIG. 1 is a front and top-left perspective view of a caliper showing our new design;
 FIG. 2 is a left side elevational view thereof;
 FIG. 3 is a right side elevational view thereof;
 FIG. 4 is a front elevational view thereof;
 FIG. 5 is a rear elevational view thereof;
 FIG. 6 is a top plan view thereof;
 FIG. 7 is a bottom plan view thereof;
 FIG. 8 is a cross-sectional view thereof as taken from line A—A of FIG. 4, the head end housing being omitted for ease of illustration.

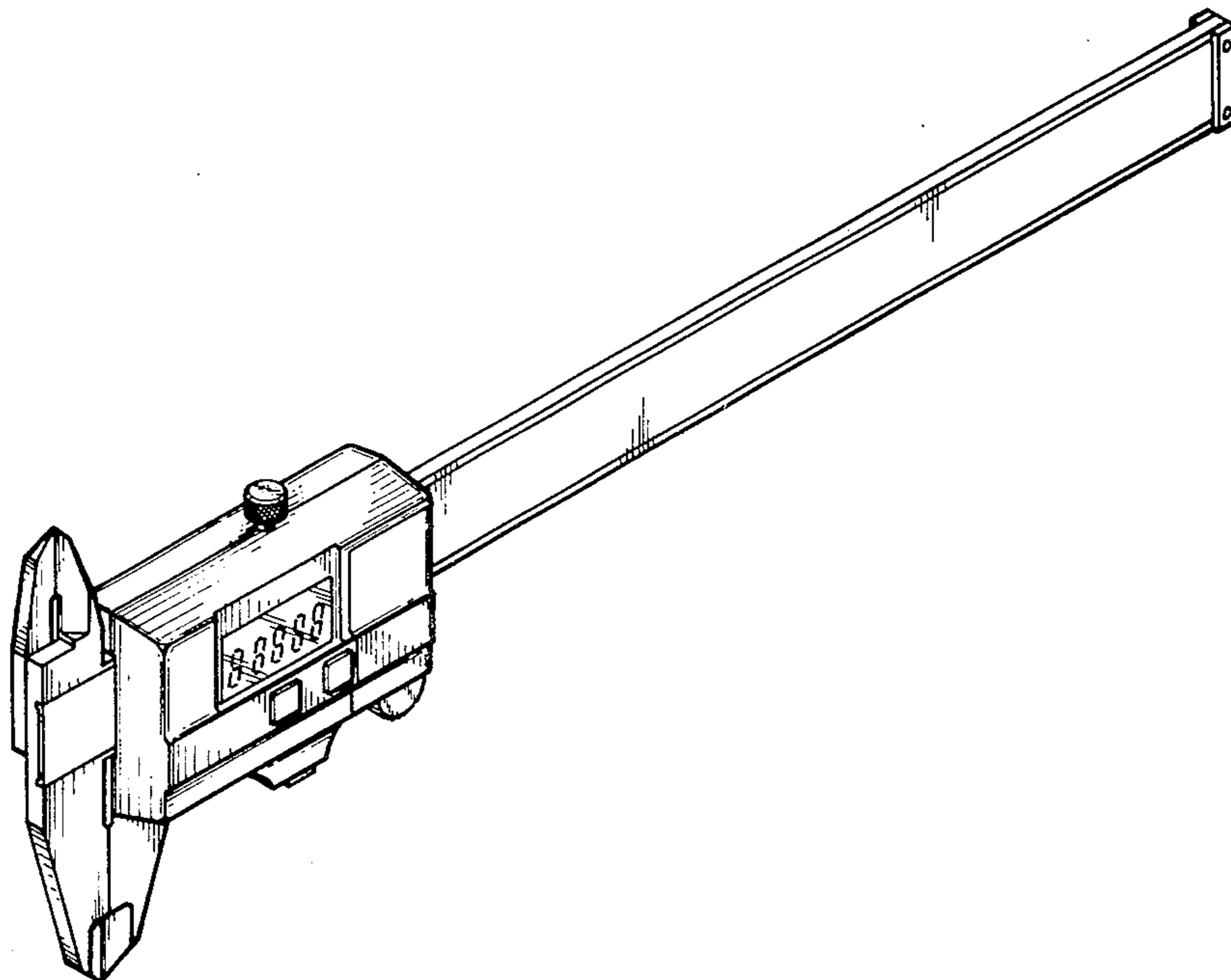

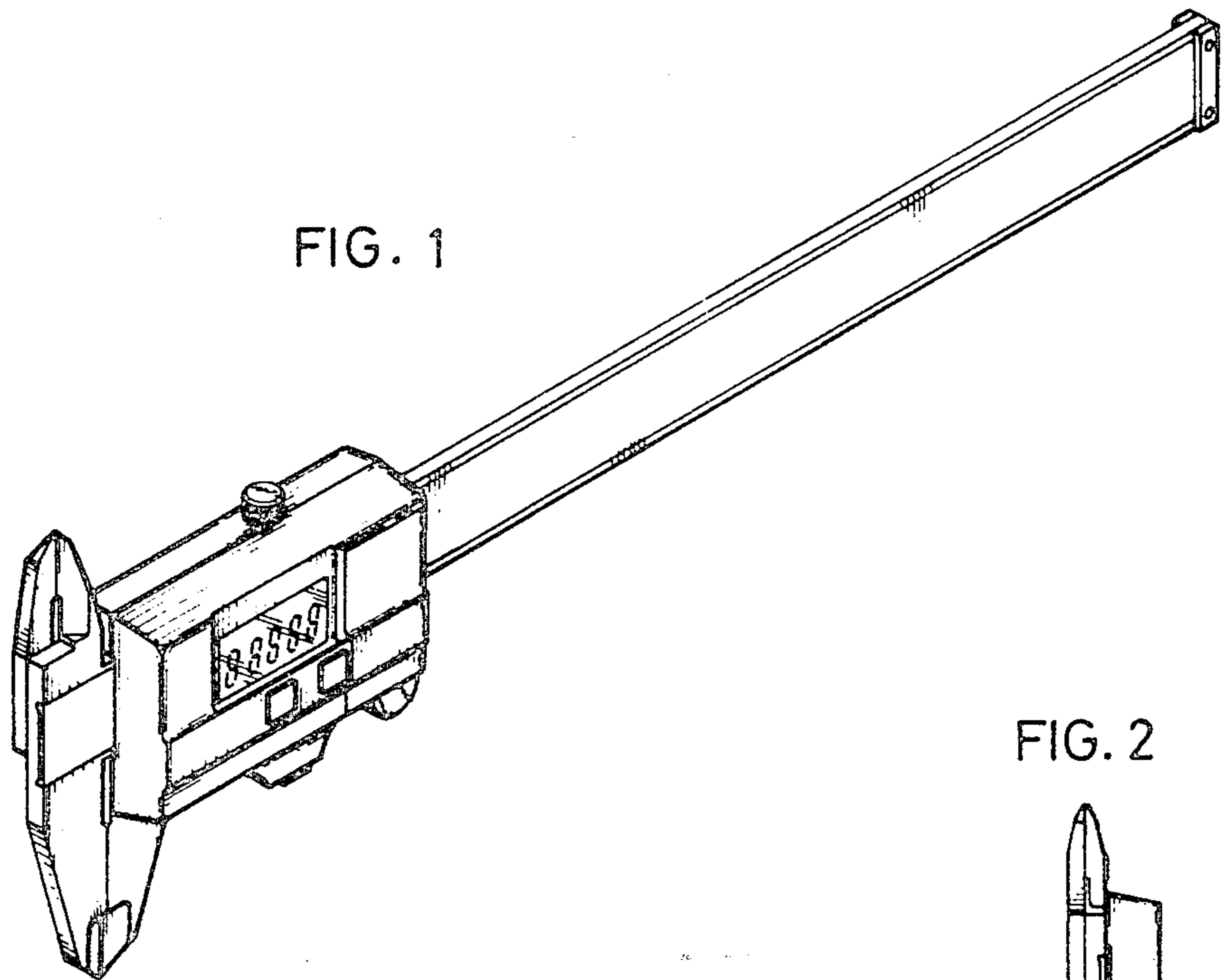

FIG. 1

FIG. 2

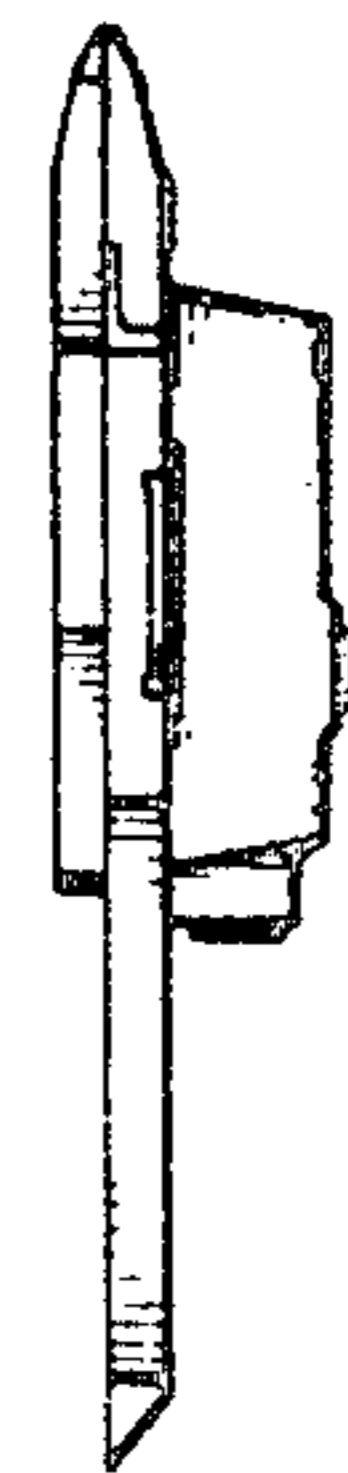
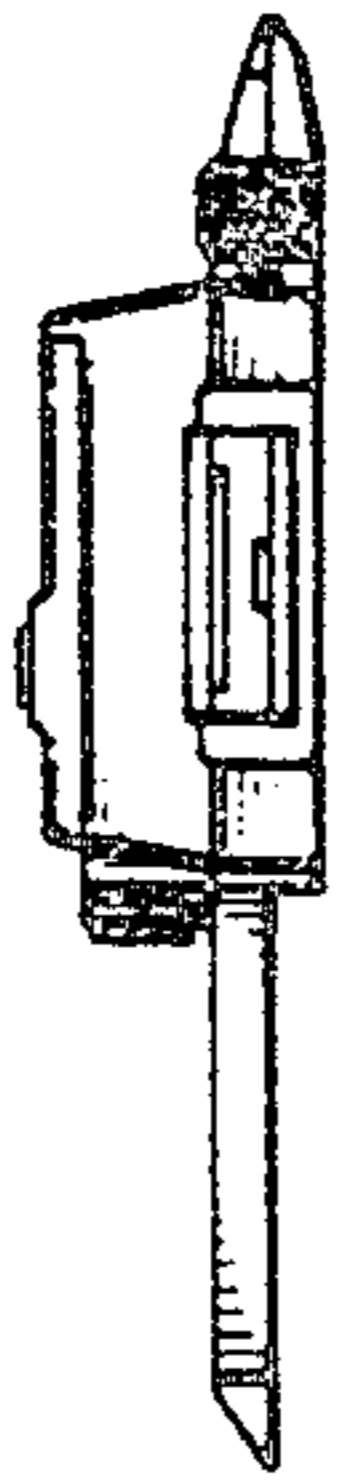

FIG. 3



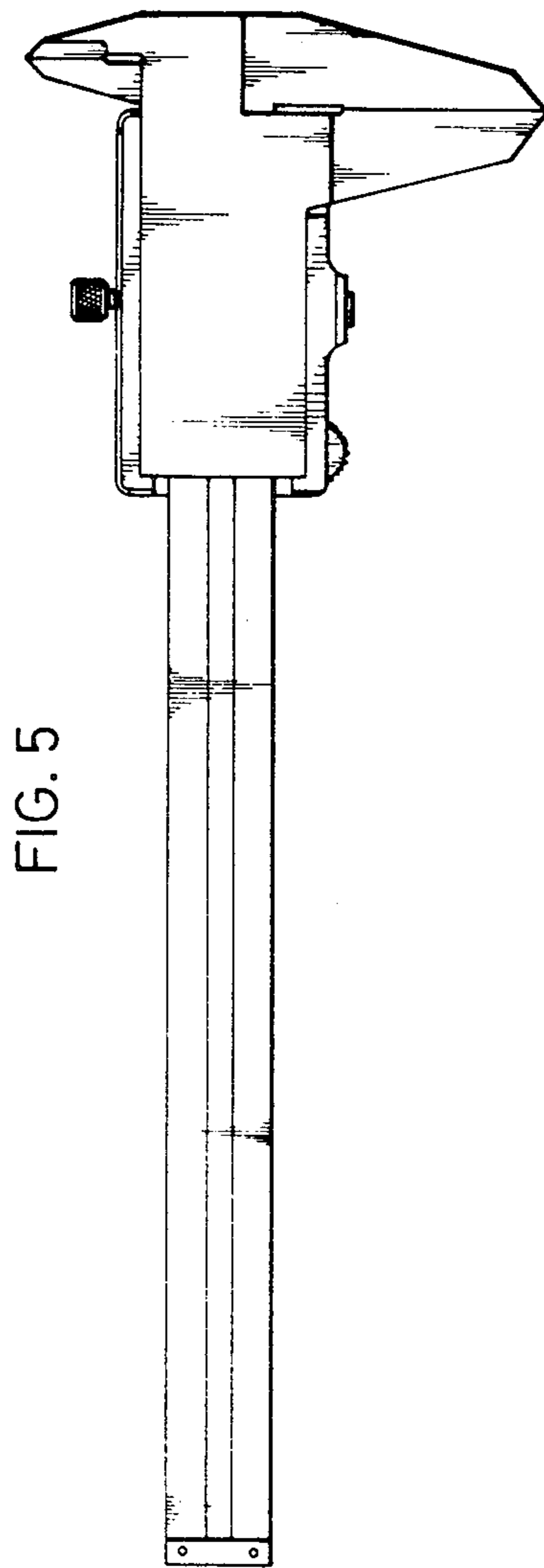
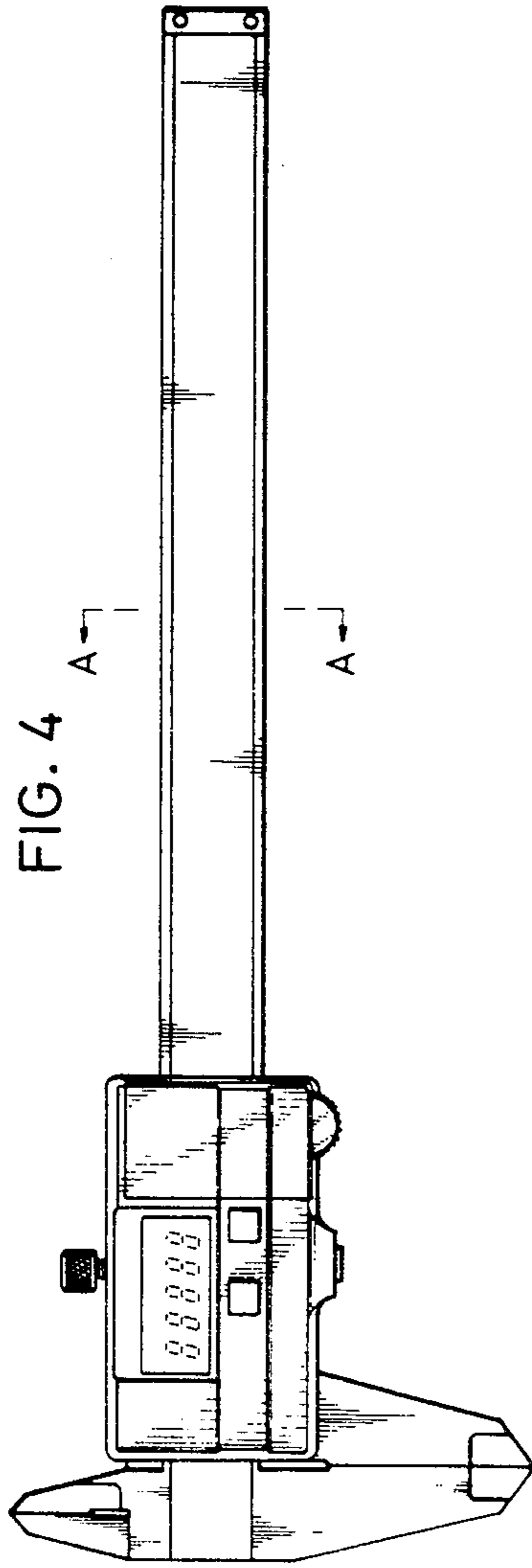

FIG. 6



FIG. 7

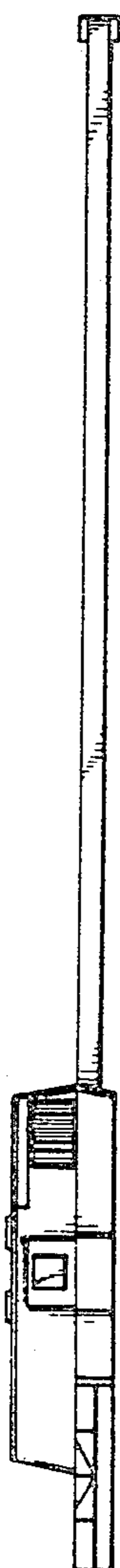

FIG. 8

