

[54] WHEEL ALIGNMENT TOOL OR SIMILAR ARTICLE

[76] Inventors: Ronnie R. Miller, Rte. 3 Box 985; Michael W. Rogers, 701 Crotty, both of Rockwall, Tex. 75087

[**] Term: 14 Years

[21] Appl. No.: 489,472

[22] Filed: Apr. 28, 1983

[52] U.S. Cl. D8/72; D10/70

[58] Field of Search D10/70, 71, 74, 103; 254/84, 98, 100; 33/180 AT, 163; 81/30 R, 30 K; D8/71, 72, 74, 394

[56] References Cited

U.S. PATENT DOCUMENTS

- D. 231,082 4/1974 Lewis D8/394
- D. 252,255 7/1979 Uyeda D8/391
- D. 272,857 2/1984 Leach D8/394

- 2,237,230 4/1941 Johnson 254/98
- 2,843,938 7/1958 Campbell 33/163
- 3,240,472 3/1966 Jones 254/100
- 3,285,622 11/1966 Castue 254/100 X
- 3,294,368 12/1966 Hunter 254/100
- 3,780,988 12/1973 Castue 254/100
- 3,874,256 4/1975 Korb 254/100 X
- 4,305,570 12/1981 Castue 254/100

Primary Examiner—Nelson C. Holtje
Attorney, Agent, or Firm—Kanz, Scherback & Timmons

[57] CLAIM

The ornamental design for wheel alignment tool or similar article, substantially as shown.

DESCRIPTION

FIG. 1 is a front and top-left perspective view of a wheel alignment tool or similar article showing our new design;

FIG. 2 is a right side elevational view thereof;

FIG. 3 is a bottom plan view thereof; and

FIG. 4 is a rear elevational view thereof.

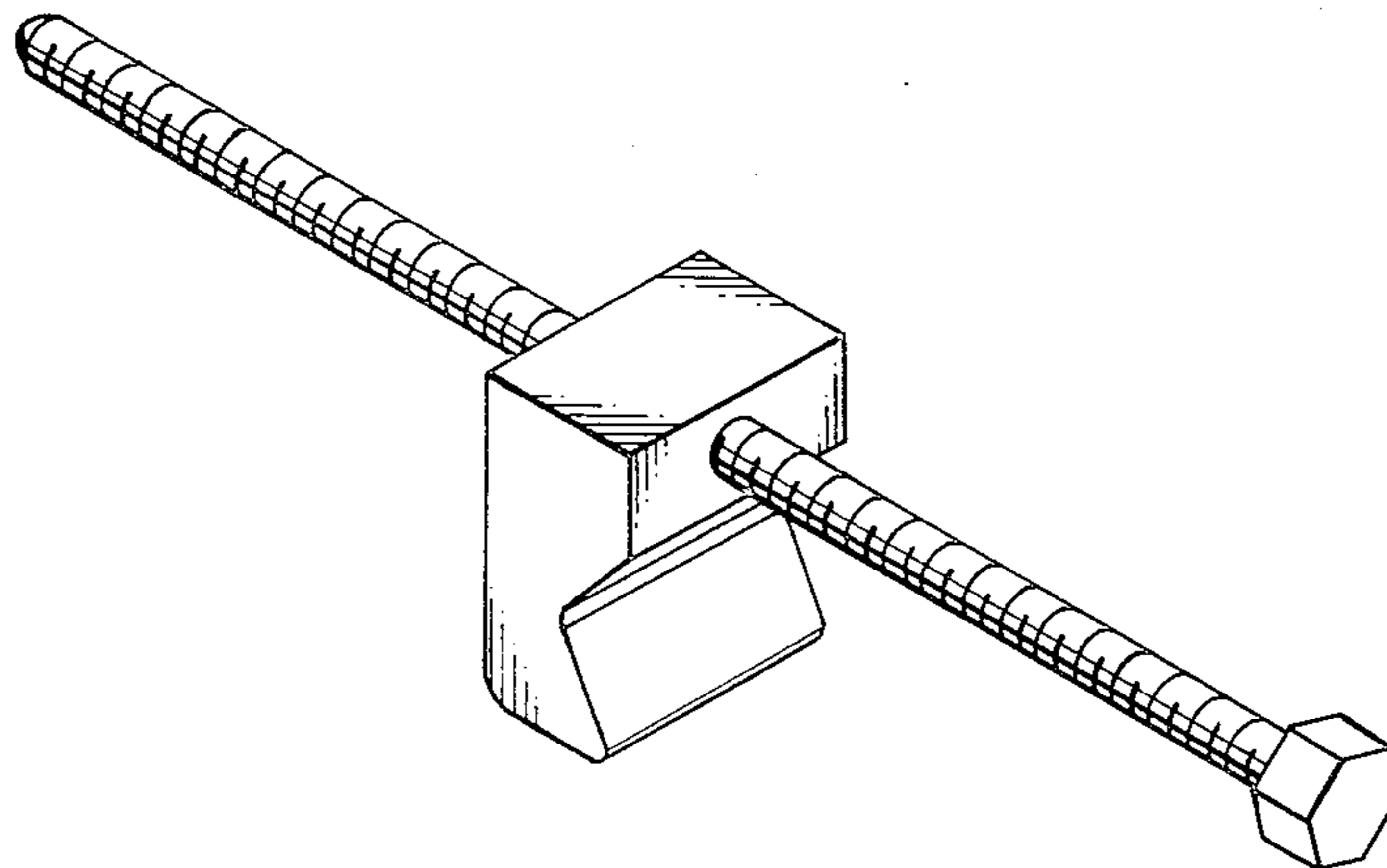

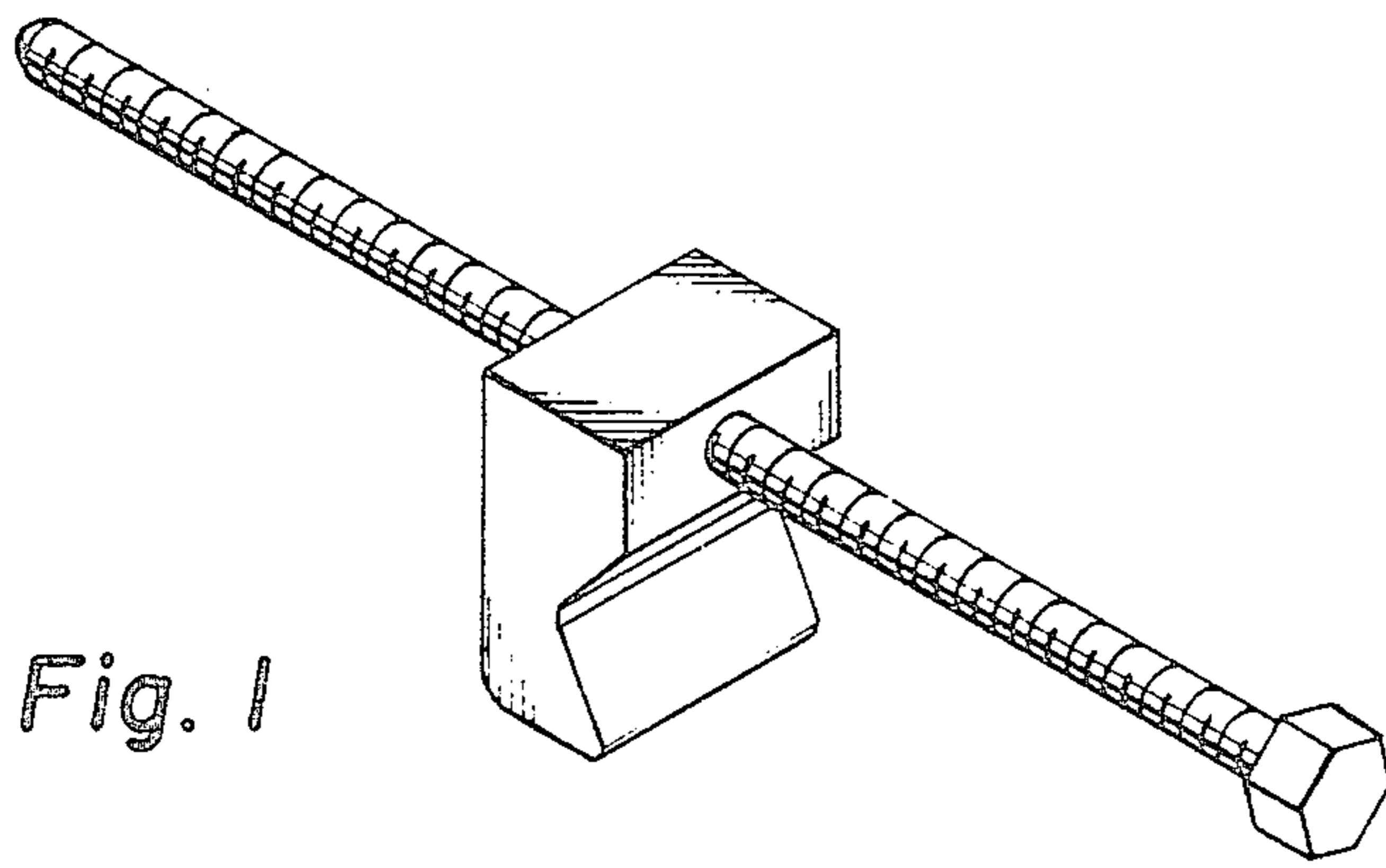

Fig. 1

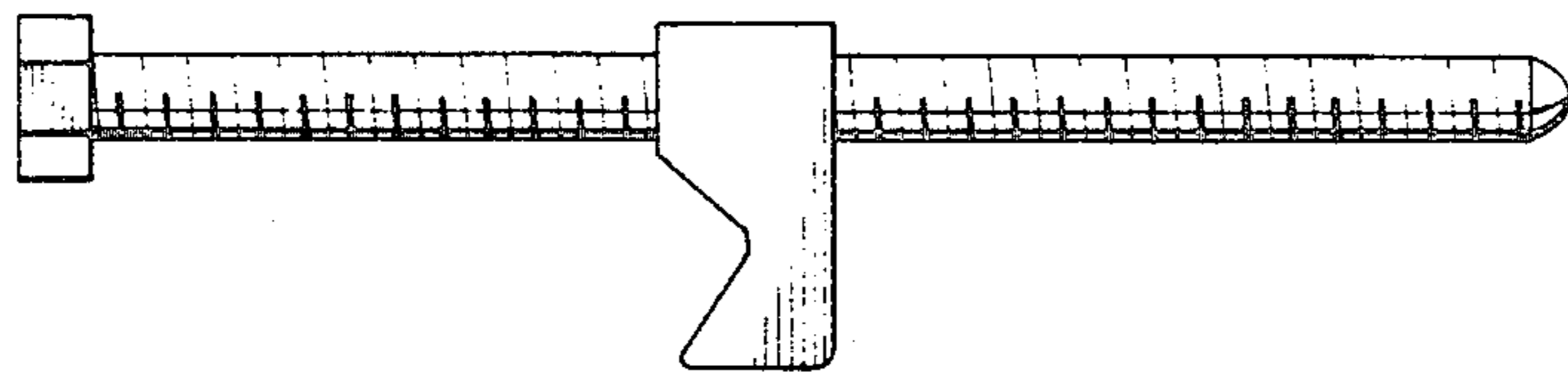

Fig. 2

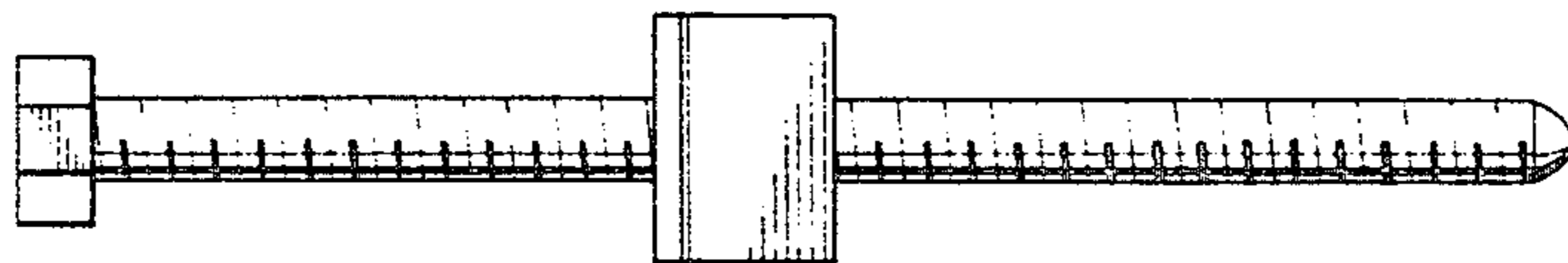

Fig. 3

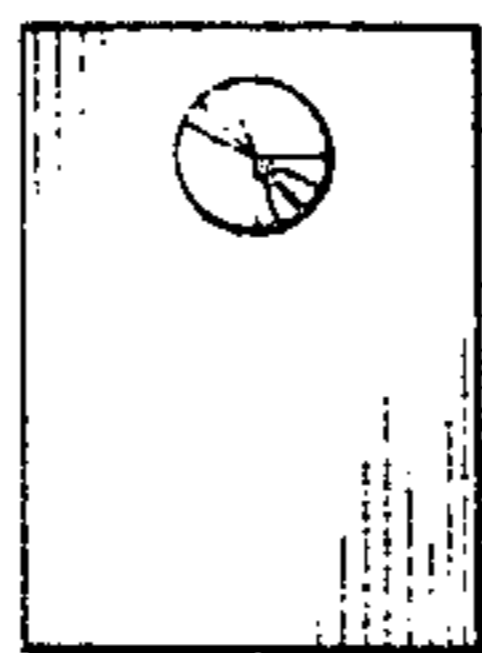

Fig. 4