

[54] ENGINE FOR MOTORCYCLE

[75] Inventors: Masato Iwakura, Asaka; Mutsuo Hirose; Yoshiyuki Yamada, both of Niiza, all of Japan

[73] Assignee: Honda Giken Kogyo Kabushiki Kaisha, Tokyo, Japan

[**] Term: 14 Years

[21] Appl. No.: 450,730

[22] Filed: Dec. 17, 1982

[30] Foreign Application Priority Data

Jun. 22, 1982 [JP] Japan 57-28098

[52] U.S. Cl. D15/1

[58] Field of Search D15/1, 3, 5; D12/110, D12/114

[56] References Cited

U.S. PATENT DOCUMENTS

D. 134,742	1/1943	Redlund	D12/114
D. 214,539	6/1969	Fullerton	D15/1
D. 255,353	6/1980	Ullrich	D15/5
D. 267,245	12/1982	Iwasaki	D12/110
D. 267,638	1/1983	Iwasaki	D12/110

OTHER PUBLICATIONS

Jane's All the World's Aircraft, 1965-1966, p. 487, 100 hp Rolls Royce/Continental O-200-A.

Extract from the enlarged issue of Japanese magazine entitled "Motorcyclist", Apr. 1, 1982, pp. 76 and 77.

Extract from the extra issue of Japanese magazine entitled "Motorcyclist", Nov. 1, 1979, pp.—unknown.

Primary Examiner—Wallace R. Burke

Assistant Examiner—Lynn Wilder

Attorney, Agent, or Firm—Armstrong, Nikaido, Marmelstein & Kubovcik

[57] CLAIM

The ornamental design for engine for motorcycle, as shown and described.

DESCRIPTION

FIG. 1 is a left side elevational view of engine for motorcycle, showing our new design;

FIG. 2 is a right side elevational view thereof;

FIG. 3 is a front elevational view thereof;

FIG. 4 is a rear elevational view thereof;

FIG. 5 is a top plan view thereof;

FIG. 6 is a bottom plan view thereof; and

FIG. 7 is a perspective view thereof.

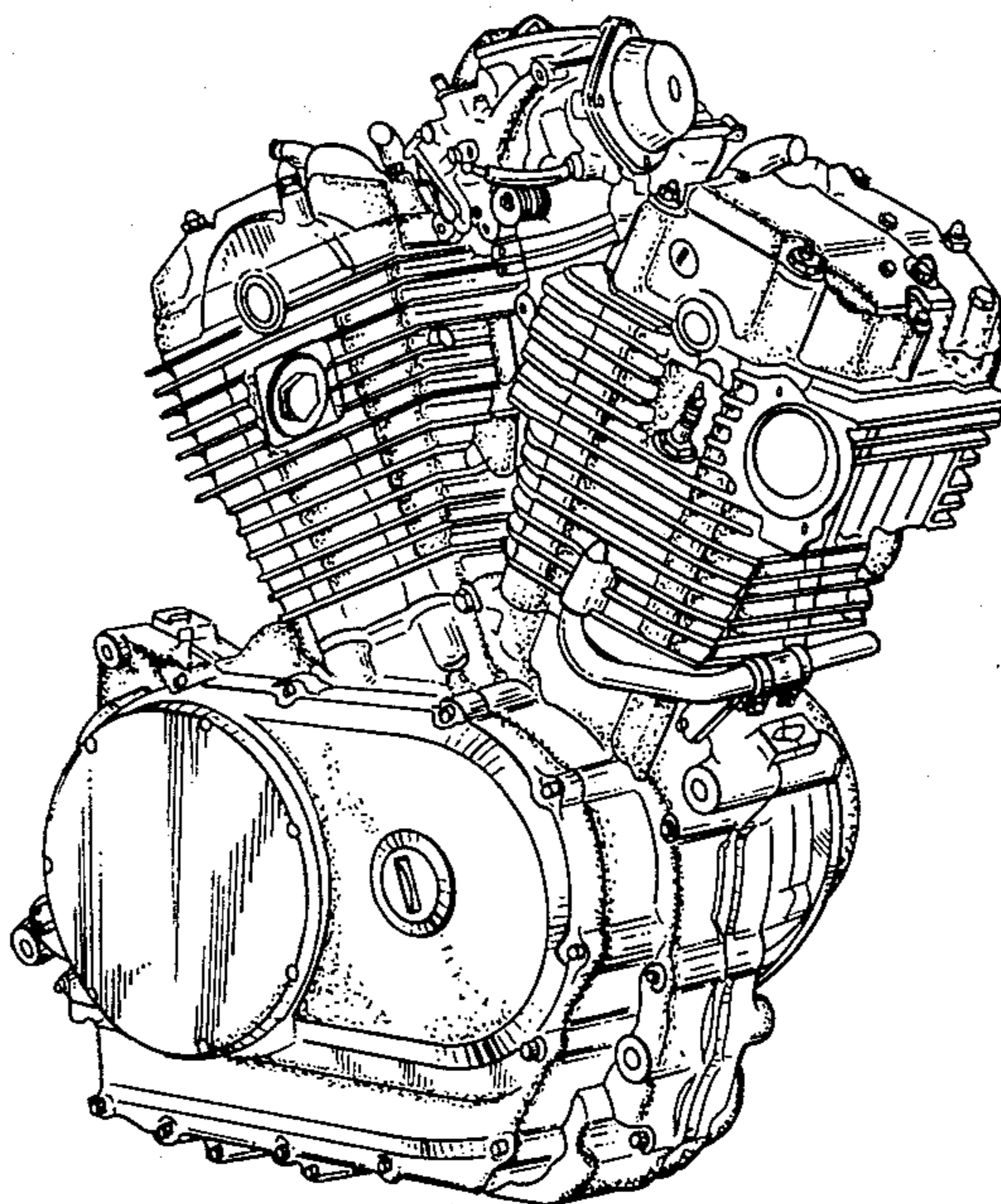

FIG. 1

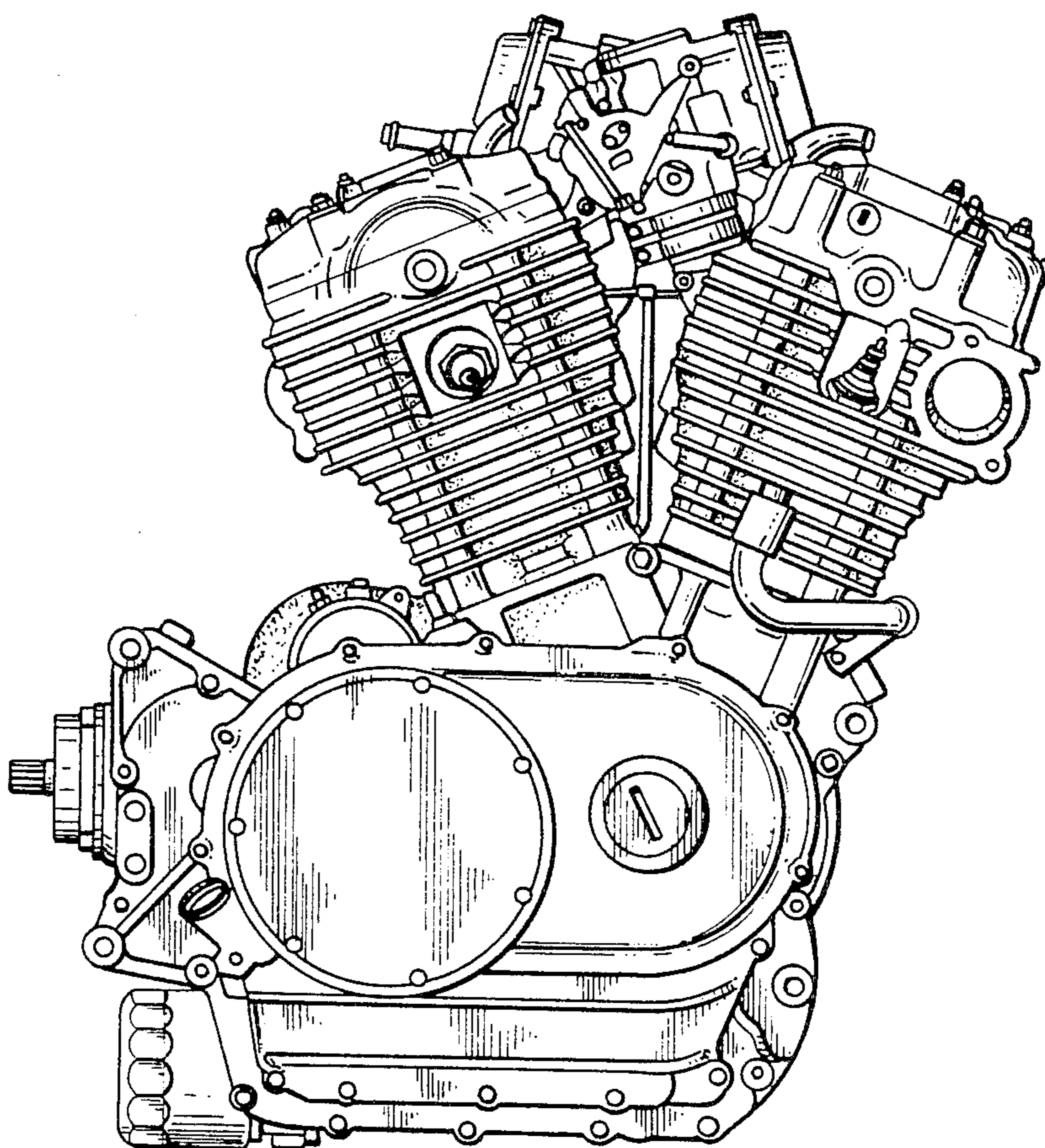

FIG. 2

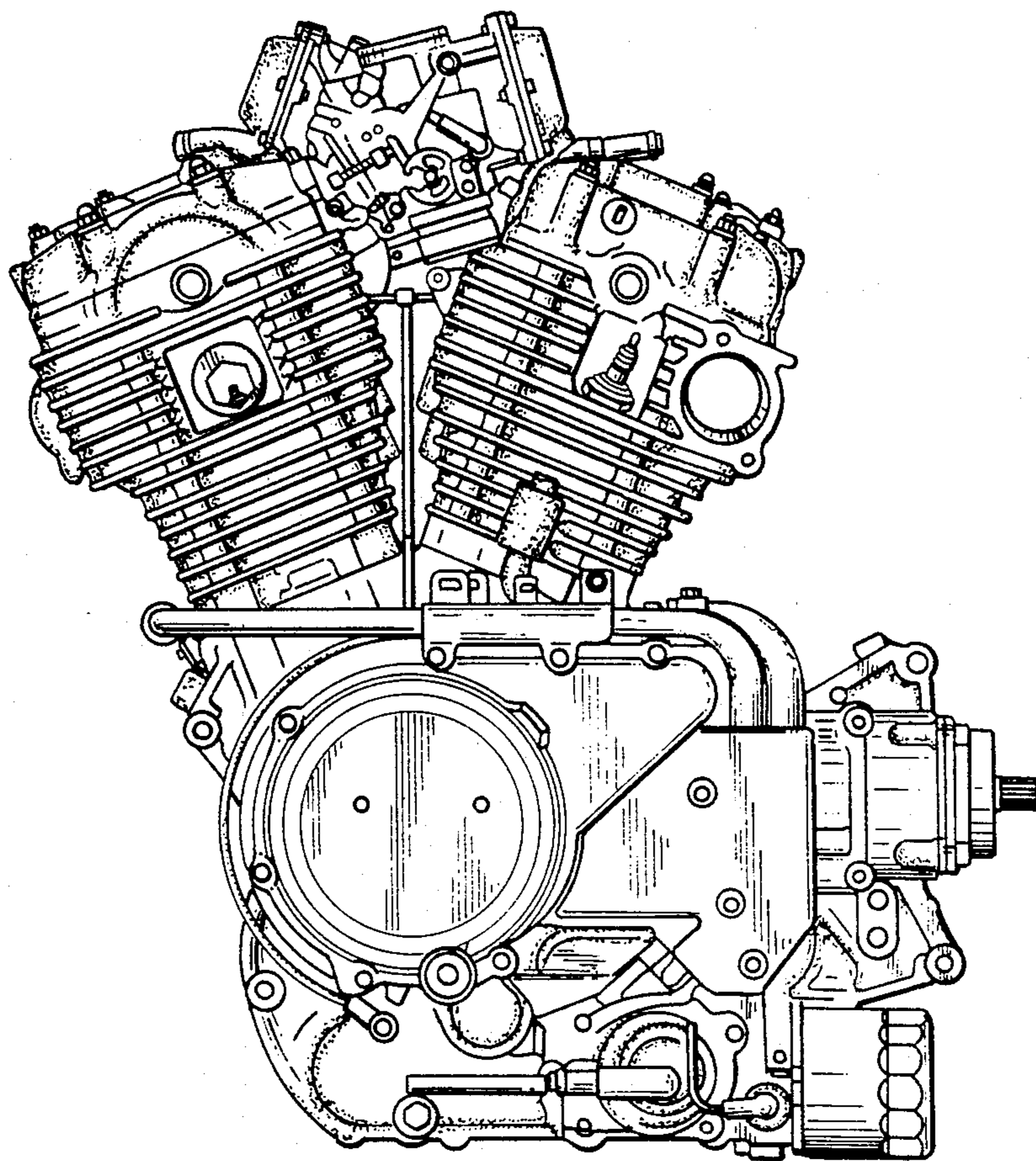

FIG. 3

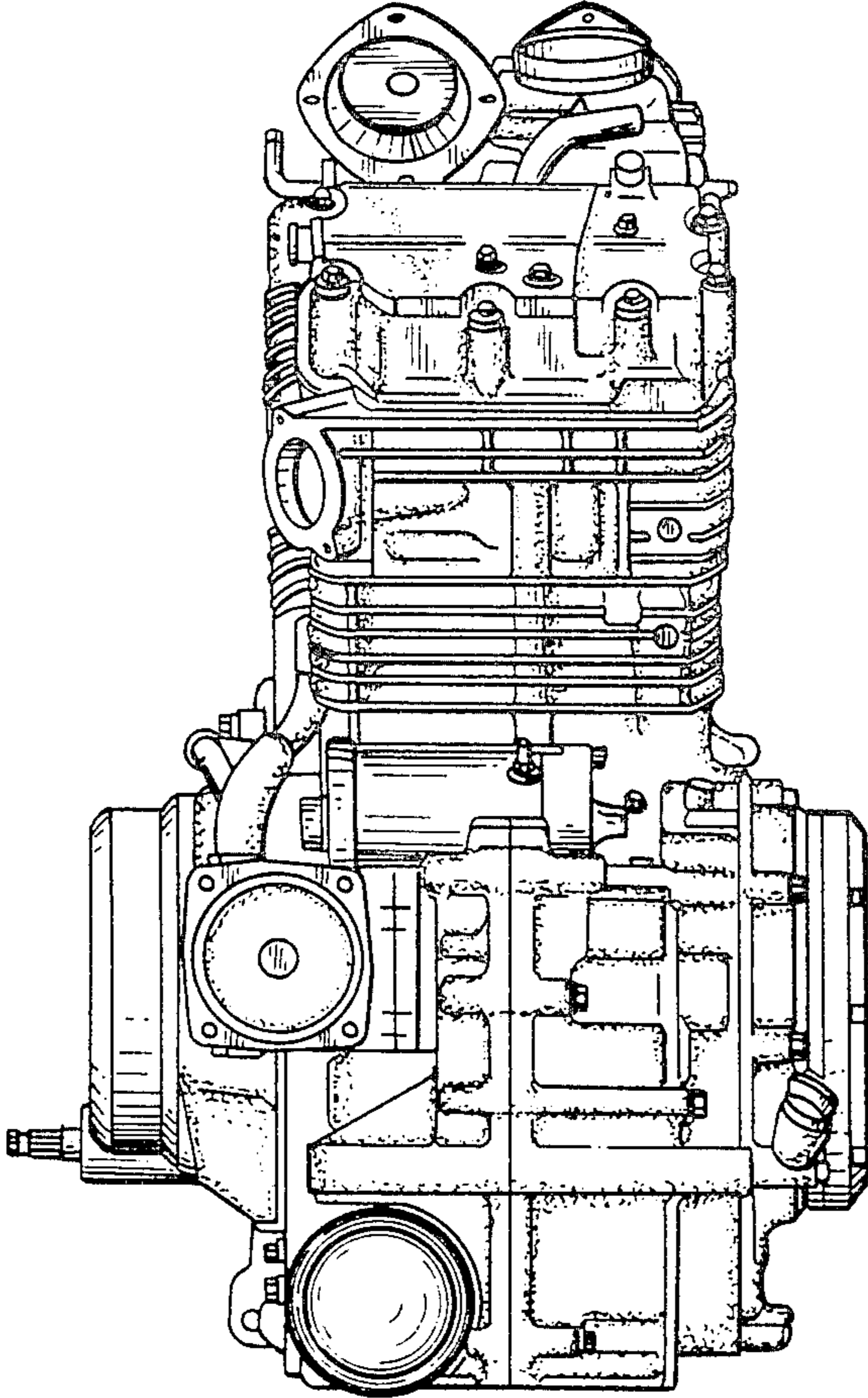

FIG. 4

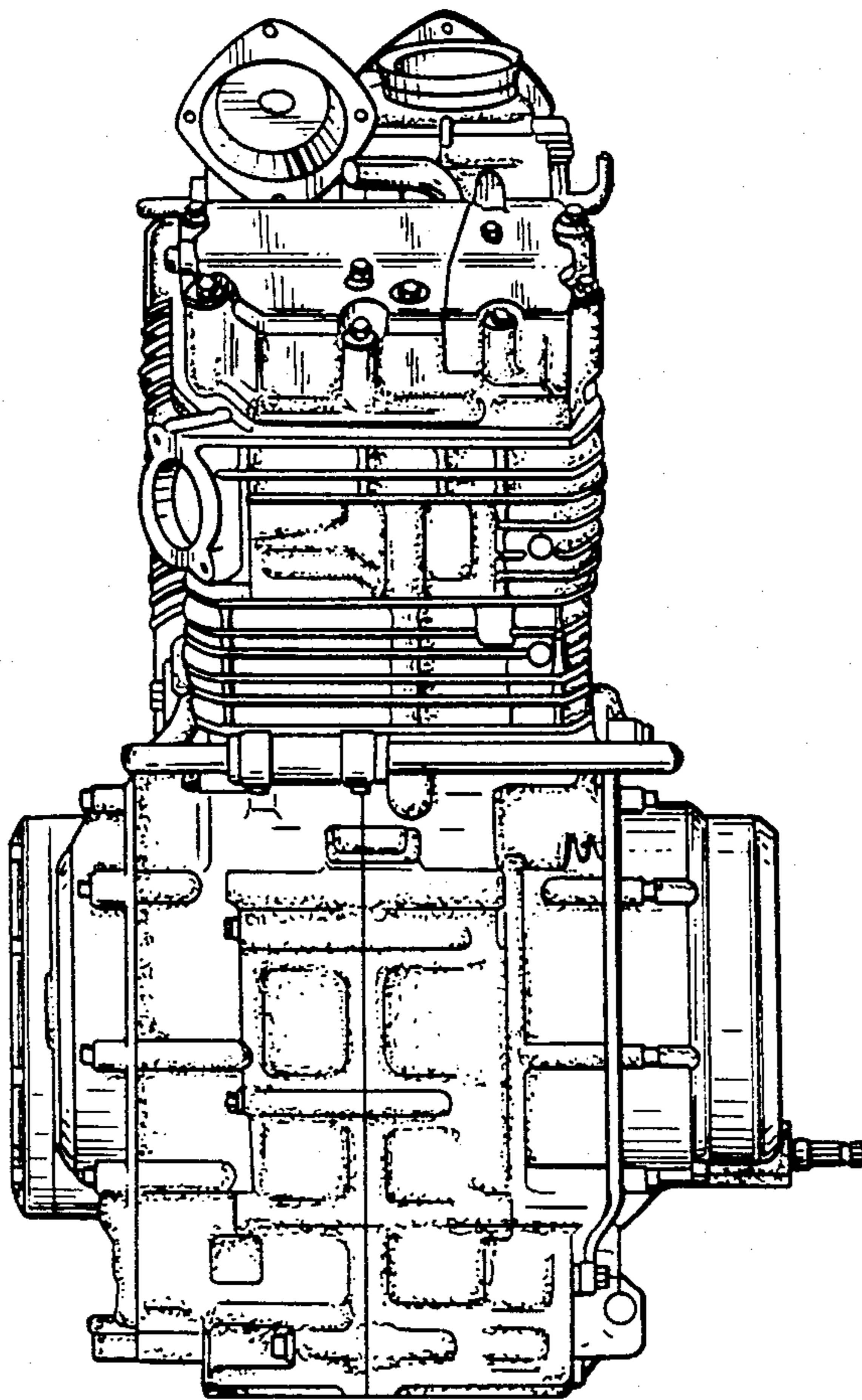

FIG. 5

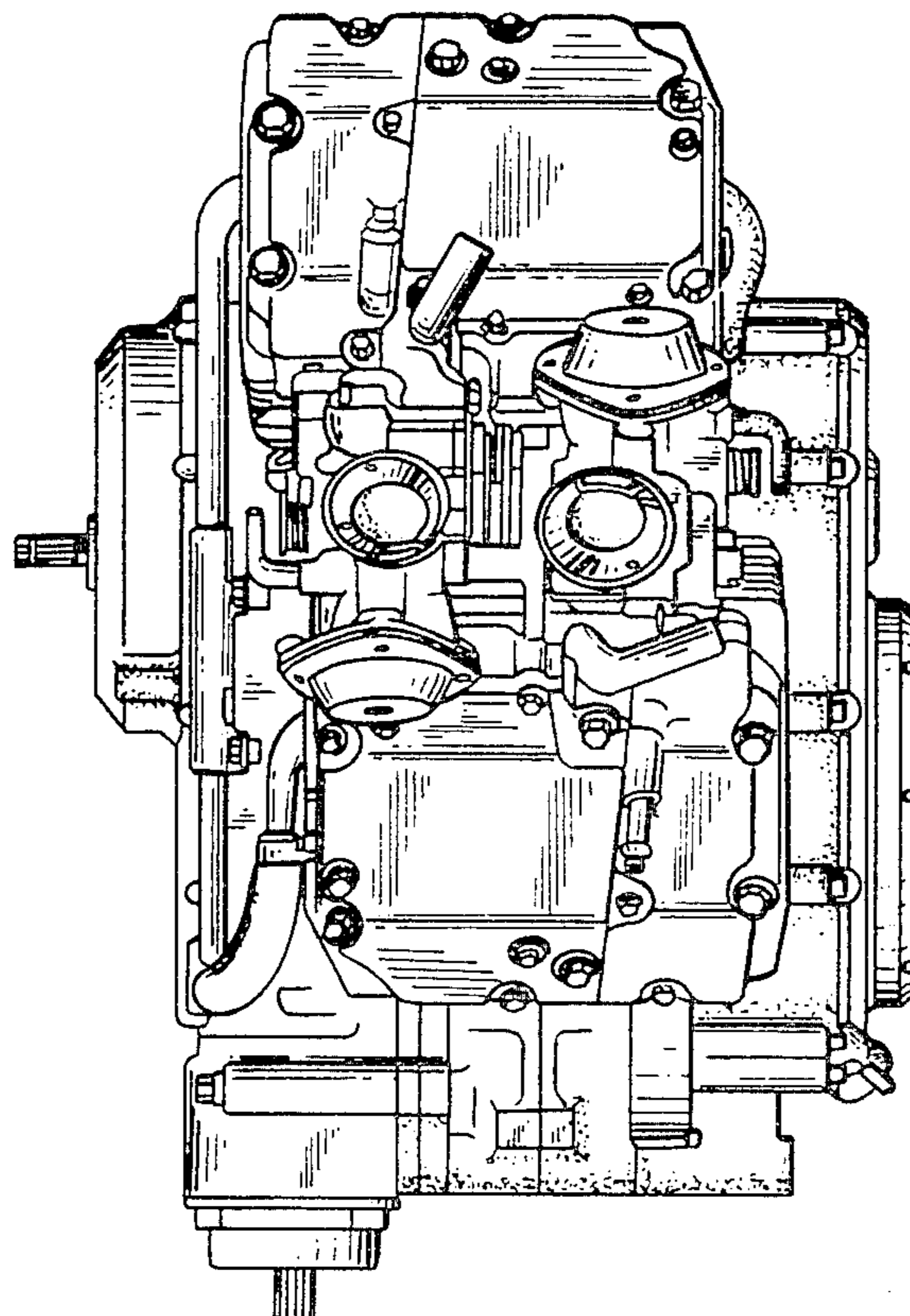

FIG. 6

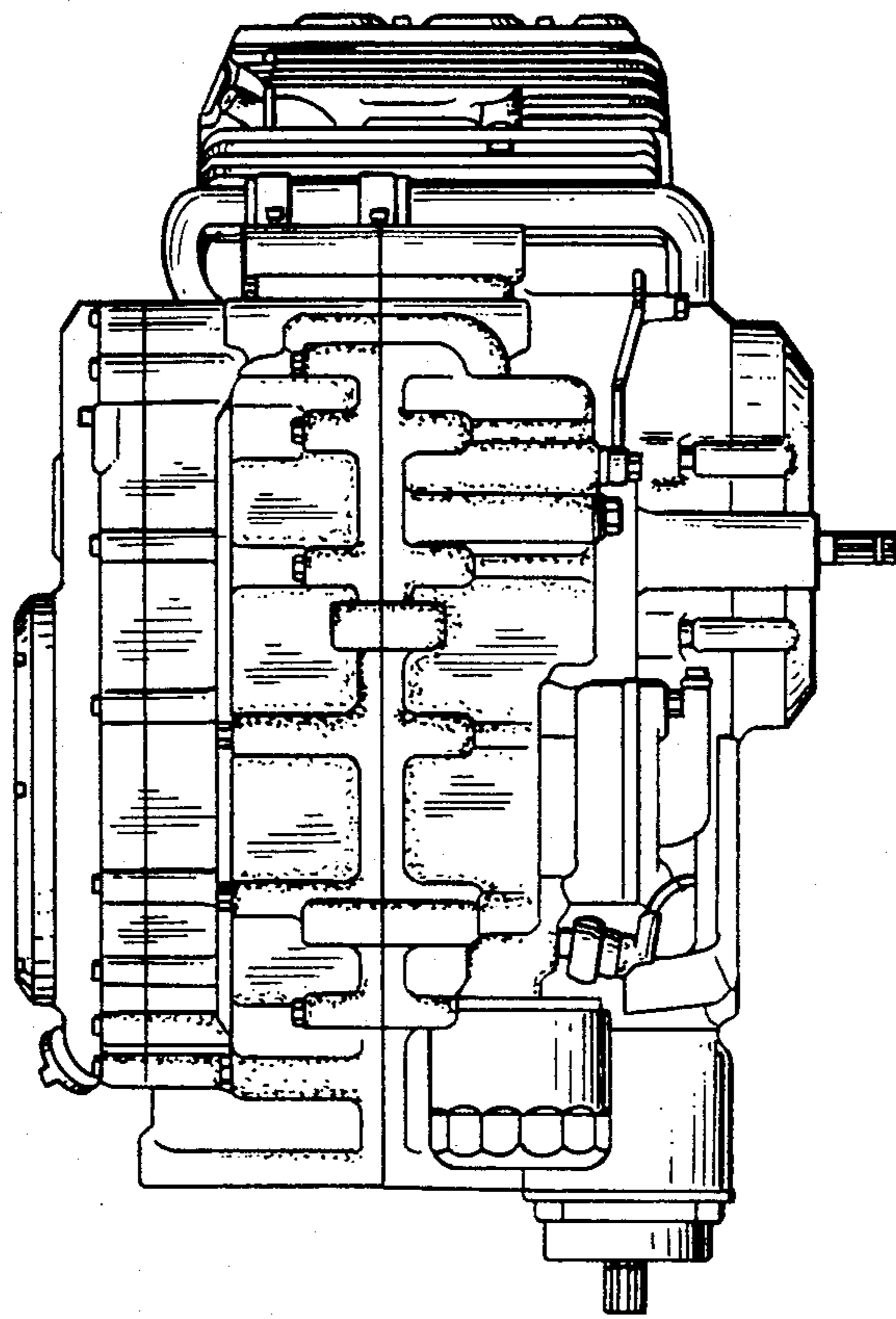

FIG. 7

