

[54] TOY AIRCRAFT

[75] Inventor: Hendrick J. G. Lorist, Santa Clara, Calif.

[73] Assignee: Tolsir Products, Santa Clara, Calif.

[**] Term: 14 Years

[21] Appl. No.: 560,545

[22] Filed: Dec. 12, 1983

[52] U.S. Cl. D21/88; D21/85

[58] Field of Search D21/82, 85, 86, 87, D21/88, 89; 244/153 R, 153 A, 154; D12/319, 521, 333

[56] References Cited

U.S. PATENT DOCUMENTS

- D. 191,752 11/1961 Dunn D21/85
- 2,593,979 4/1952 Calhoun 244/154
- 2,801,063 7/1957 O'Gorman 244/154

- 2,827,252 3/1958 Pohl 244/154
- 3,107,888 10/1963 Finn 244/154

FOREIGN PATENT DOCUMENTS

- 2005373 8/1971 Fed. Rep. of Germany 244/16

Primary Examiner—Charles A. Rademaker
Attorney, Agent, or Firm—Thomas E. Schatzel

[57] CLAIM

The ornamental design for a toy aircraft, as shown and described.

DESCRIPTION

- FIG. 1 is a perspective view of a toy aircraft showing my new design;
- FIG. 2 is a side elevational view thereof, the side opposite being a mirror image;
- FIG. 3 is a top plan view thereof;
- FIG. 4 is a front elevational view thereof;
- FIG. 5 is a rear elevational view thereof; and,
- FIG. 6 is a bottom plan view thereof.

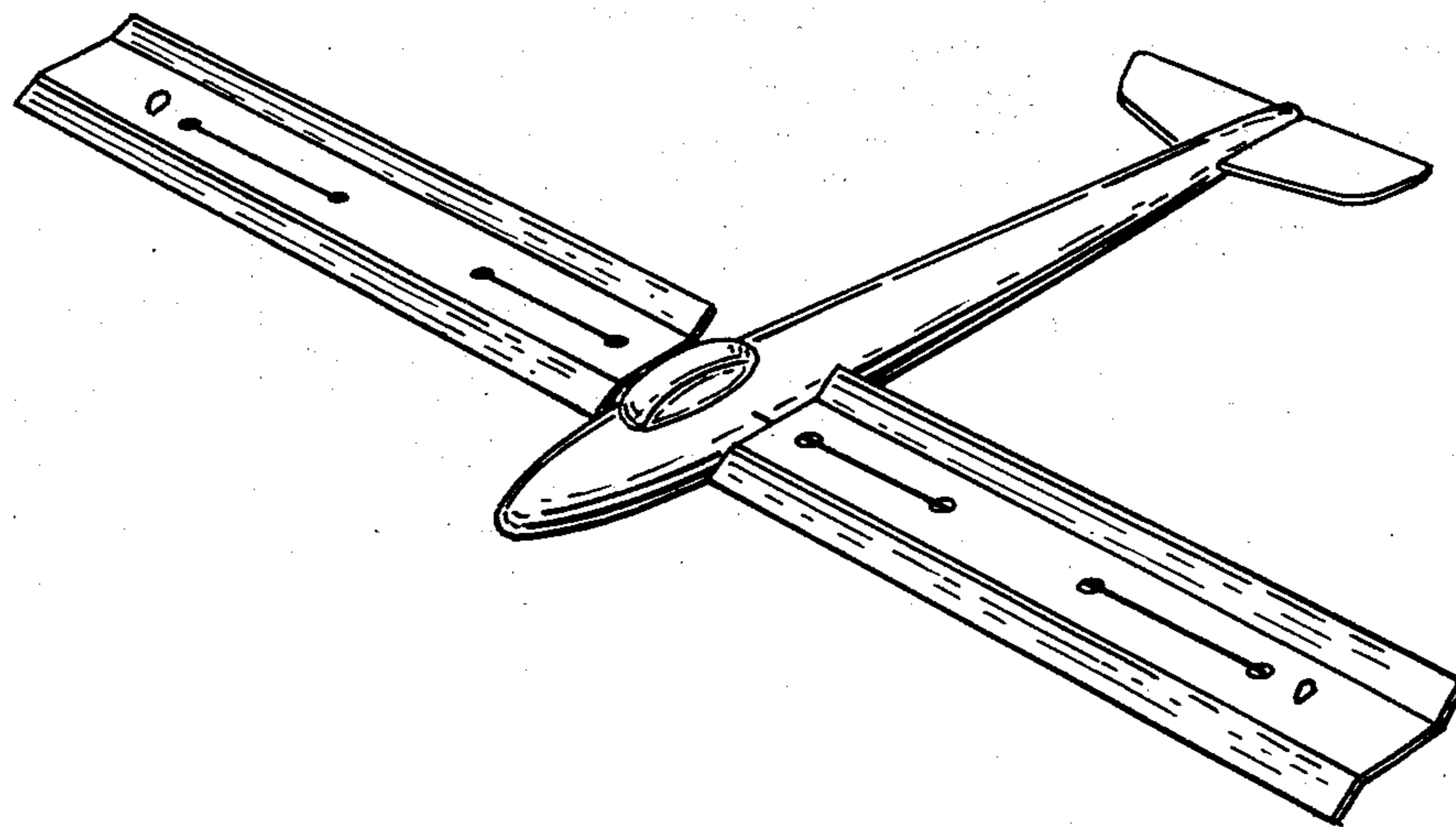

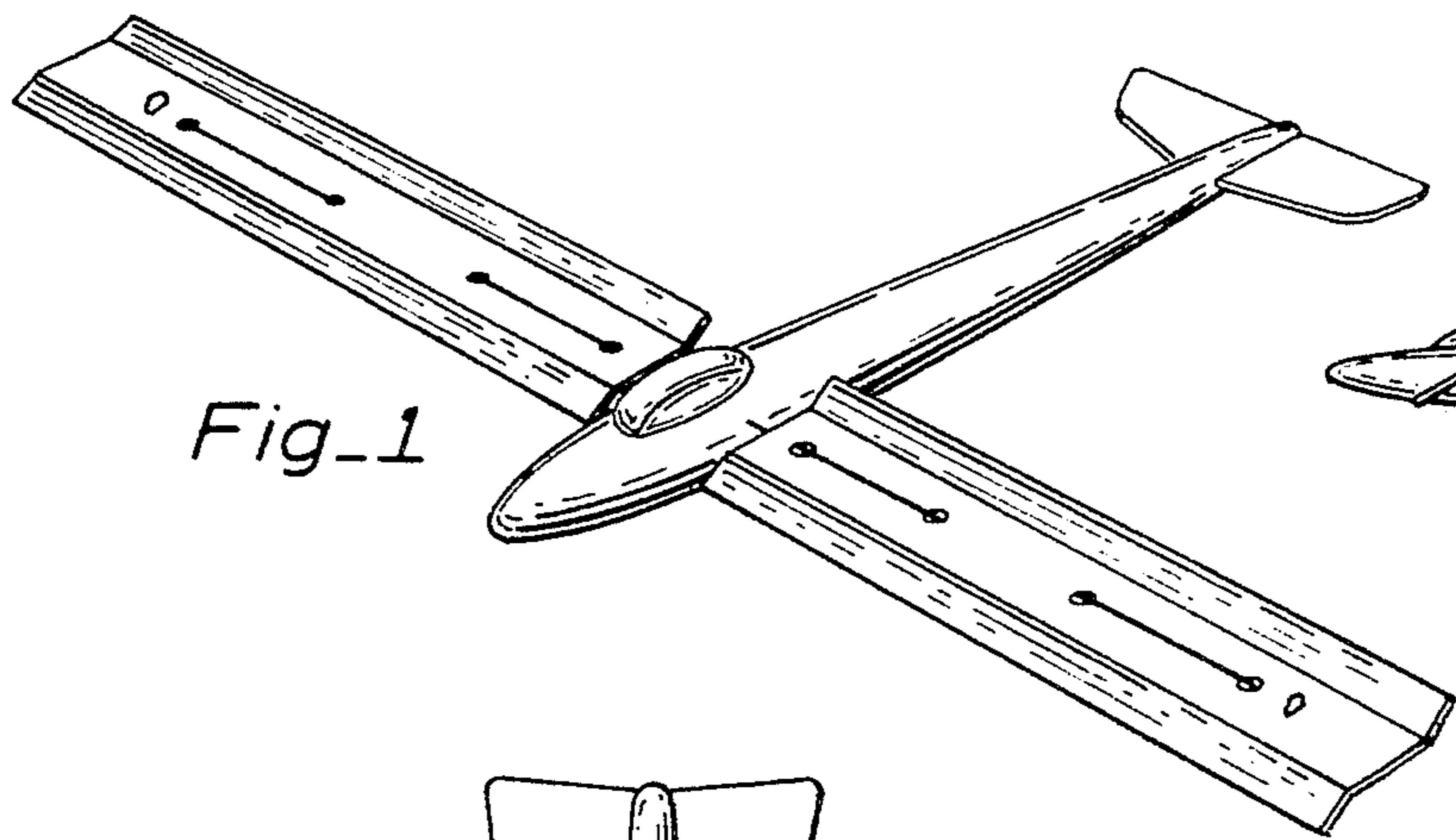

Fig. 1

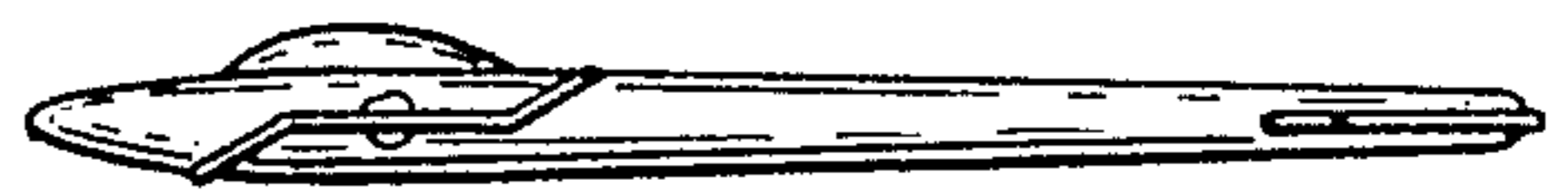

Fig. 2

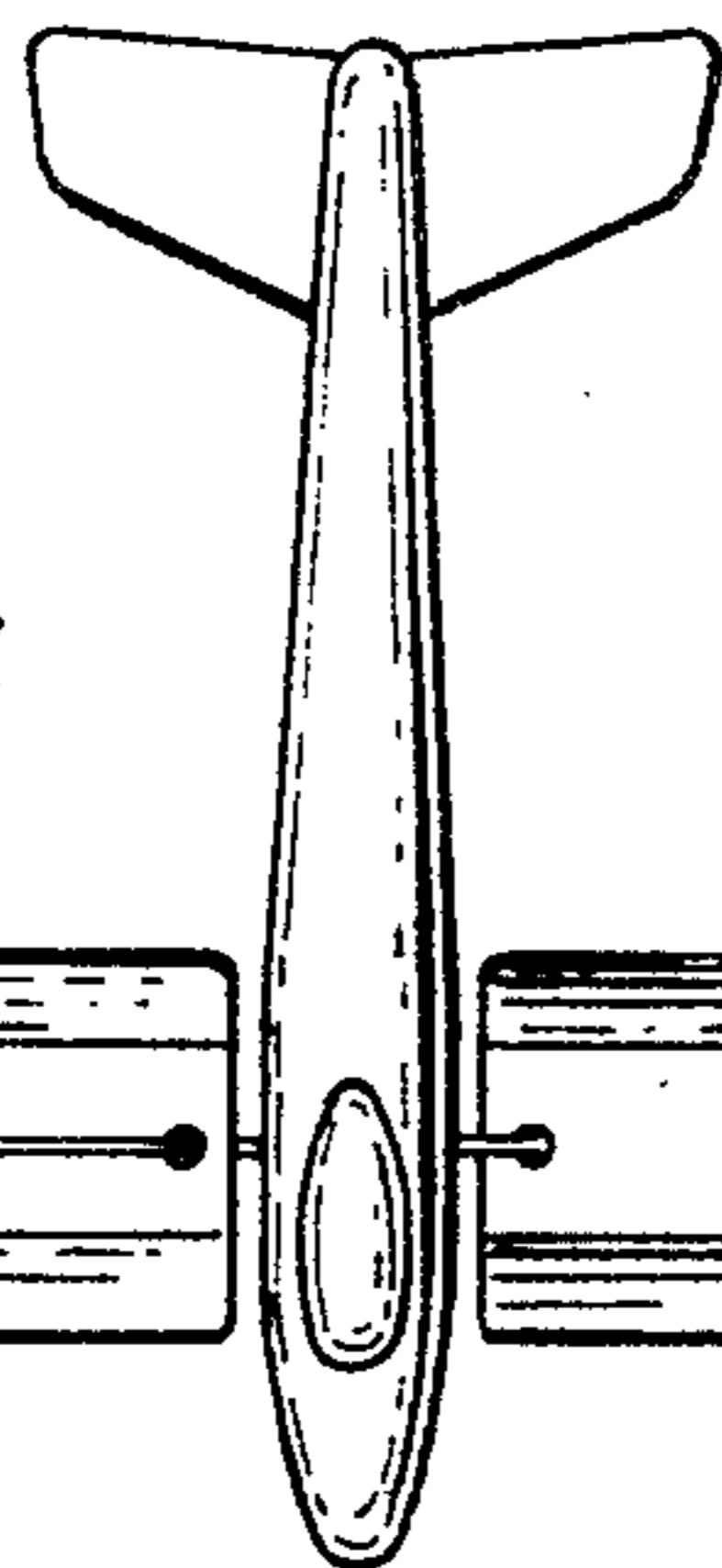

Fig. 3

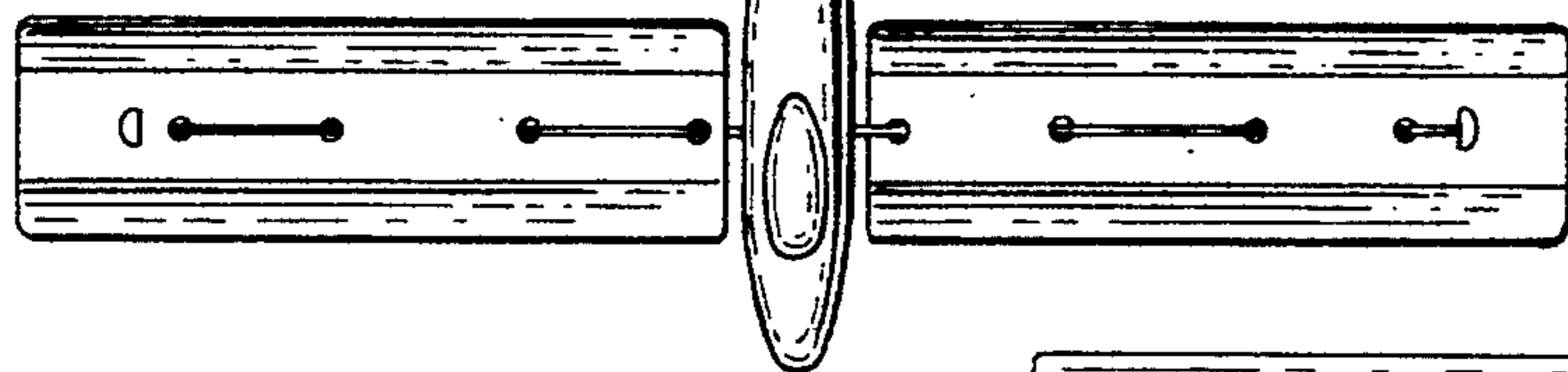

Fig. 4

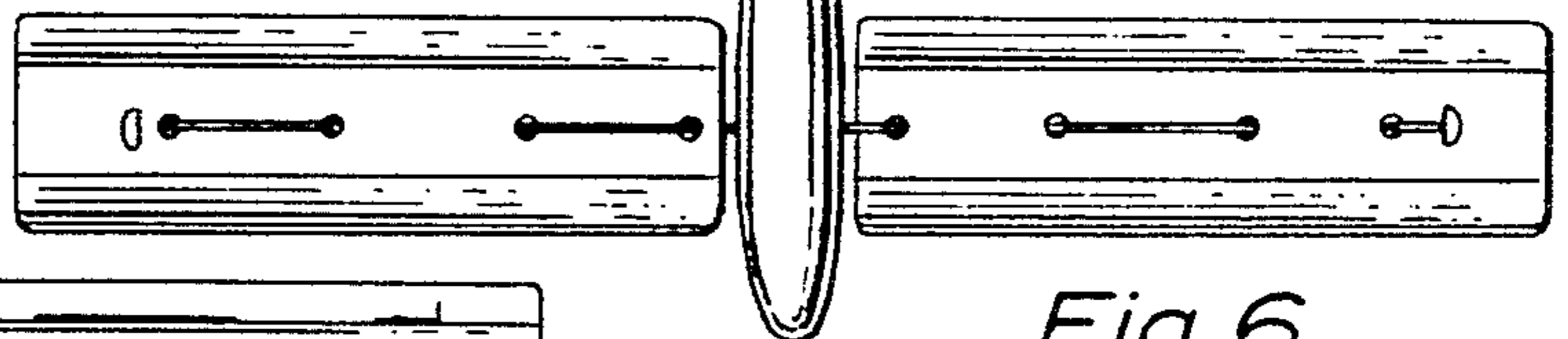

Fig. 6



Fig. 5