

[54] CAR LUGGAGE CARRIER

[76] Inventor: Herbert H. McKee, 135 Poplar Ave., NW., Canton, Ohio 44708

[**] Term: 14 Years

[21] Appl. No.: 470,231

[22] Filed: Feb. 28, 1983

[52] U.S. Cl. D12/157

[58] Field of Search D12/157, 156; 224/42.03 A, 42.04, 42.42; 296/37.1, 164

[56] References Cited

U.S. PATENT DOCUMENTS

D. 229,829	1/1974	Arnold, Jr.	D12/156
D. 236,456	8/1975	Pelton et al.	D12/157
D. 238,351	1/1976	Bell et al.	D12/156
D. 238,352	1/1976	Dissman et al.	D12/156
D. 249,674	9/1978	Tamura et al.	D12/156

3,228,576	1/1966	Gaukel	224/42.03 A
3,999,693	12/1976	Cooper	224/42.03 A

Primary Examiner—James M. Gandy
Attorney, Agent, or Firm—Frease & Bishop

[57] CLAIM

The ornamental design for a car luggage carrier, as shown and described.

DESCRIPTION

FIG. 1 is a perspective view of a car luggage carrier, showing my new design;
 FIG. 2 is a right side elevational view thereof, it being understood that the dot/dash lines are for illustrative purposes only;
 FIG. 3 is a left side elevational view thereof;
 FIG. 4 is a top plan view thereof;
 FIG. 5 is a bottom plan view thereof;
 FIG. 6 is a front elevational view thereof; and
 FIG. 7 is a rear elevational view thereof.

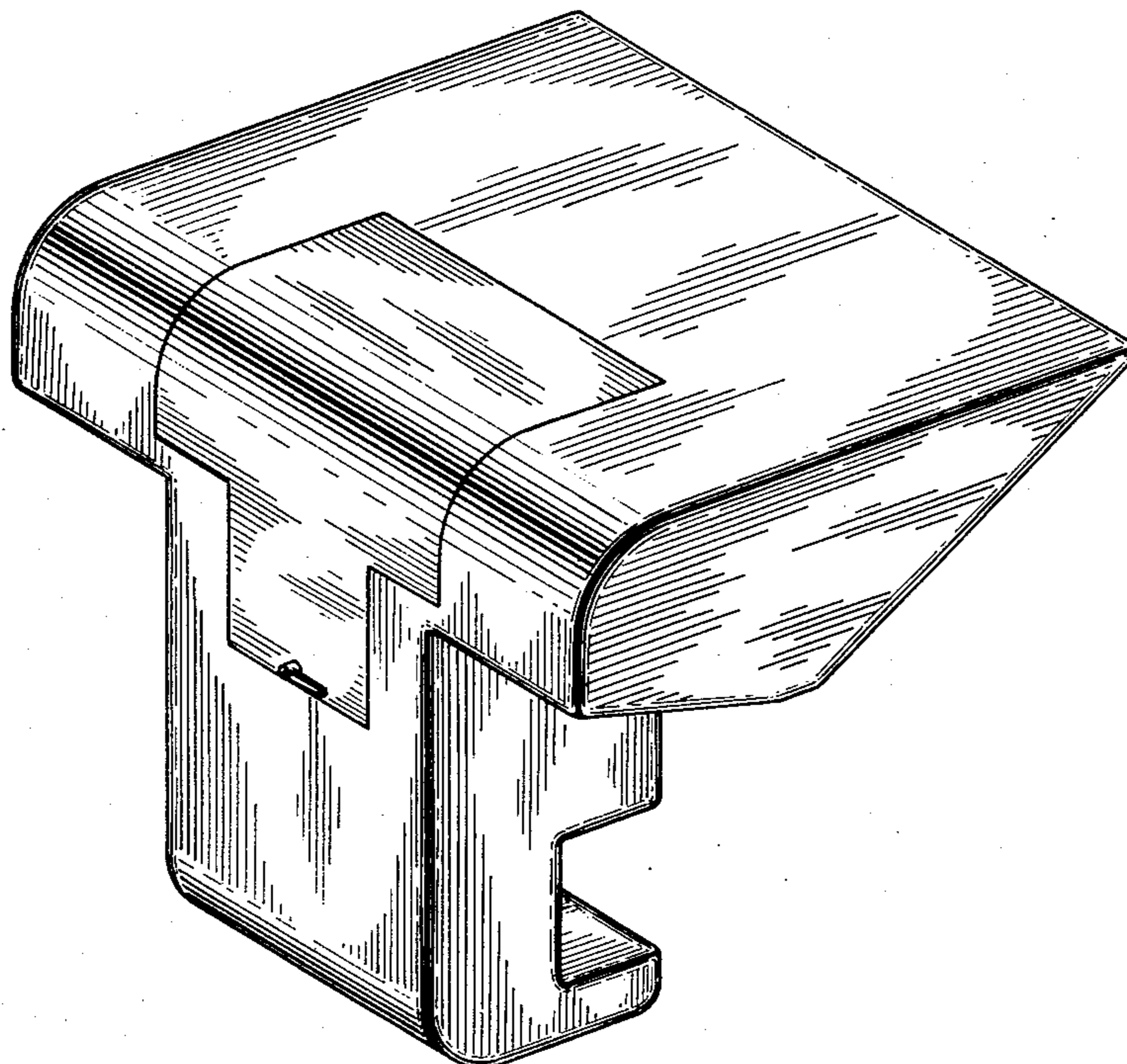

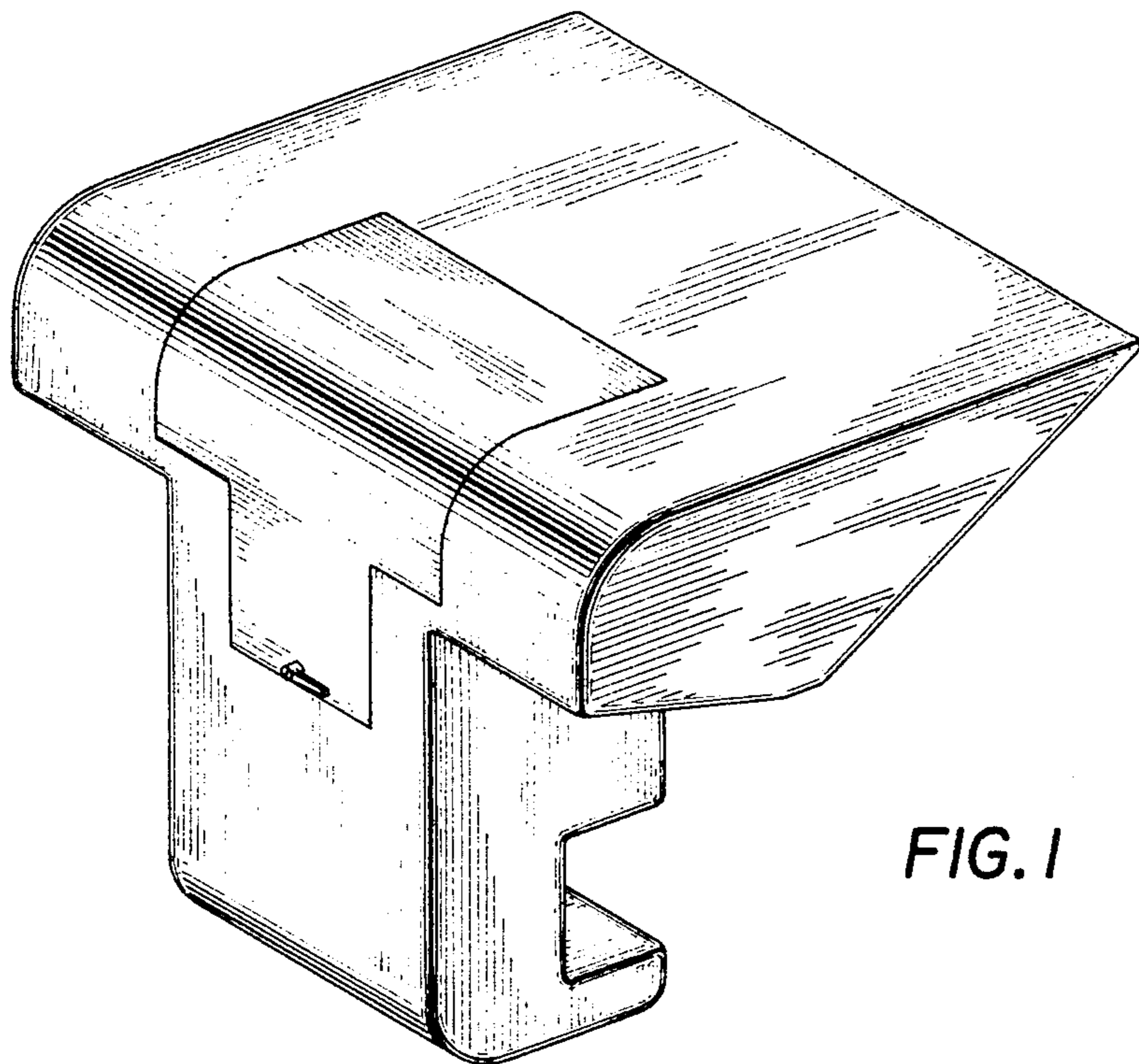

FIG. 1

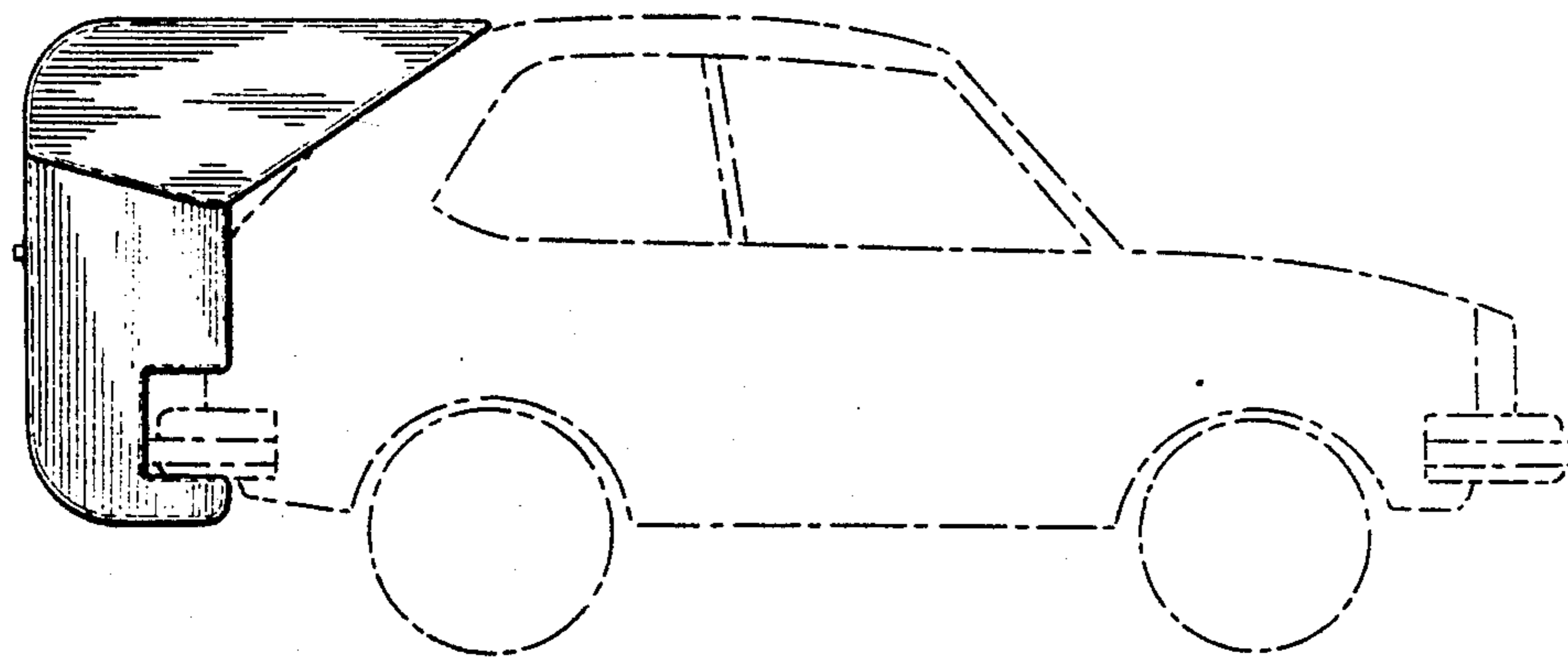

FIG. 2

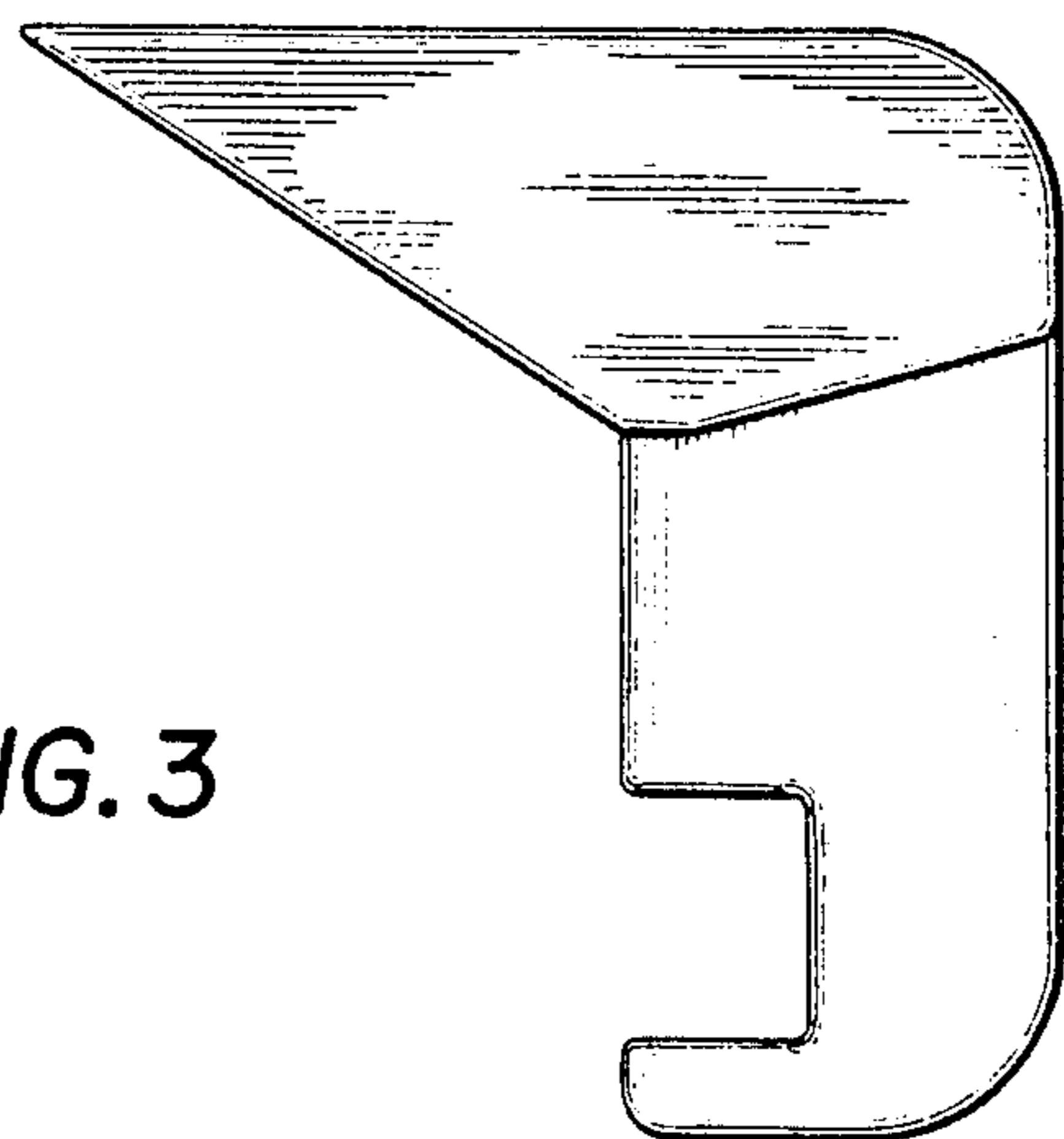

FIG. 3

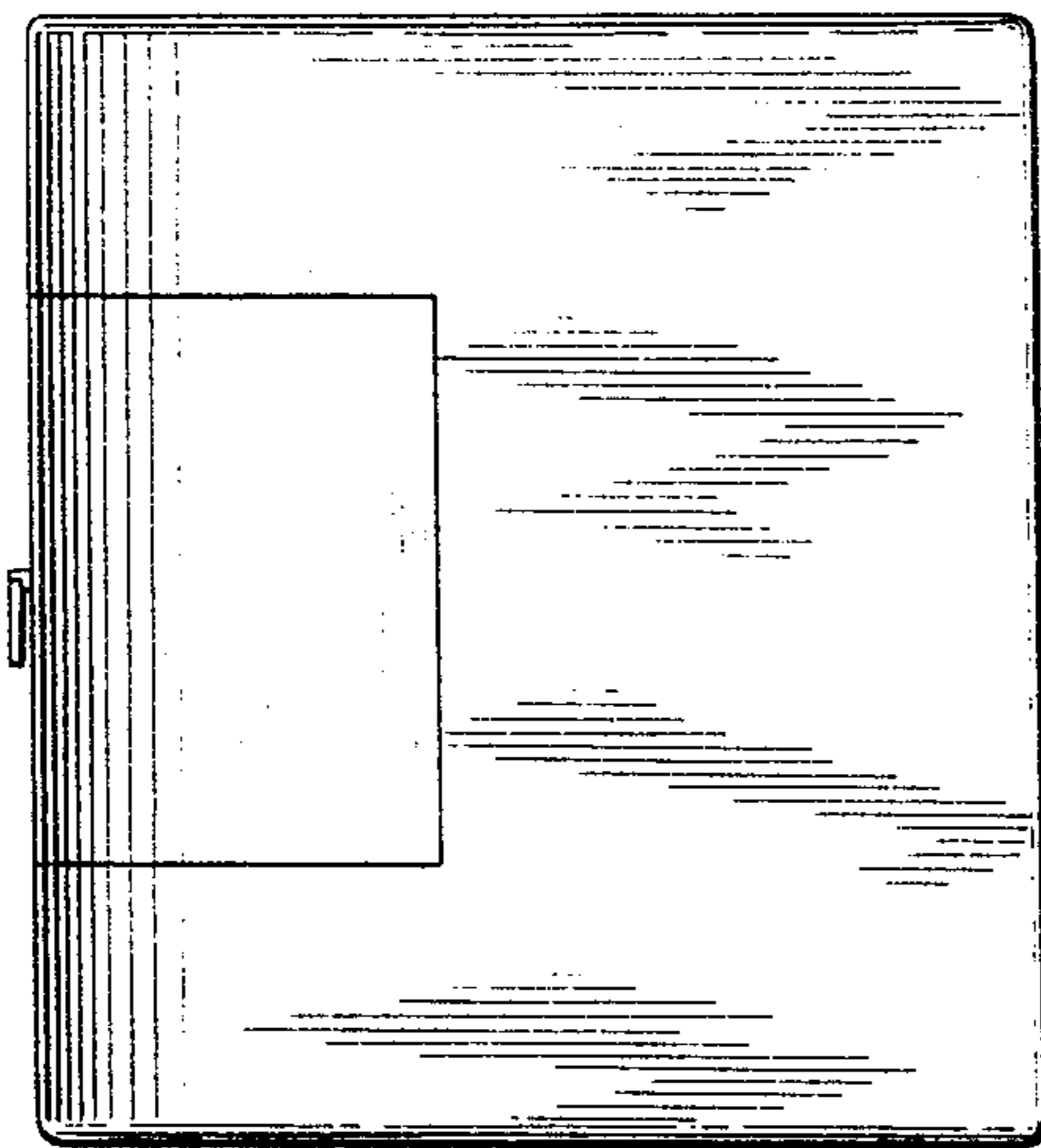

FIG. 4

FIG. 5

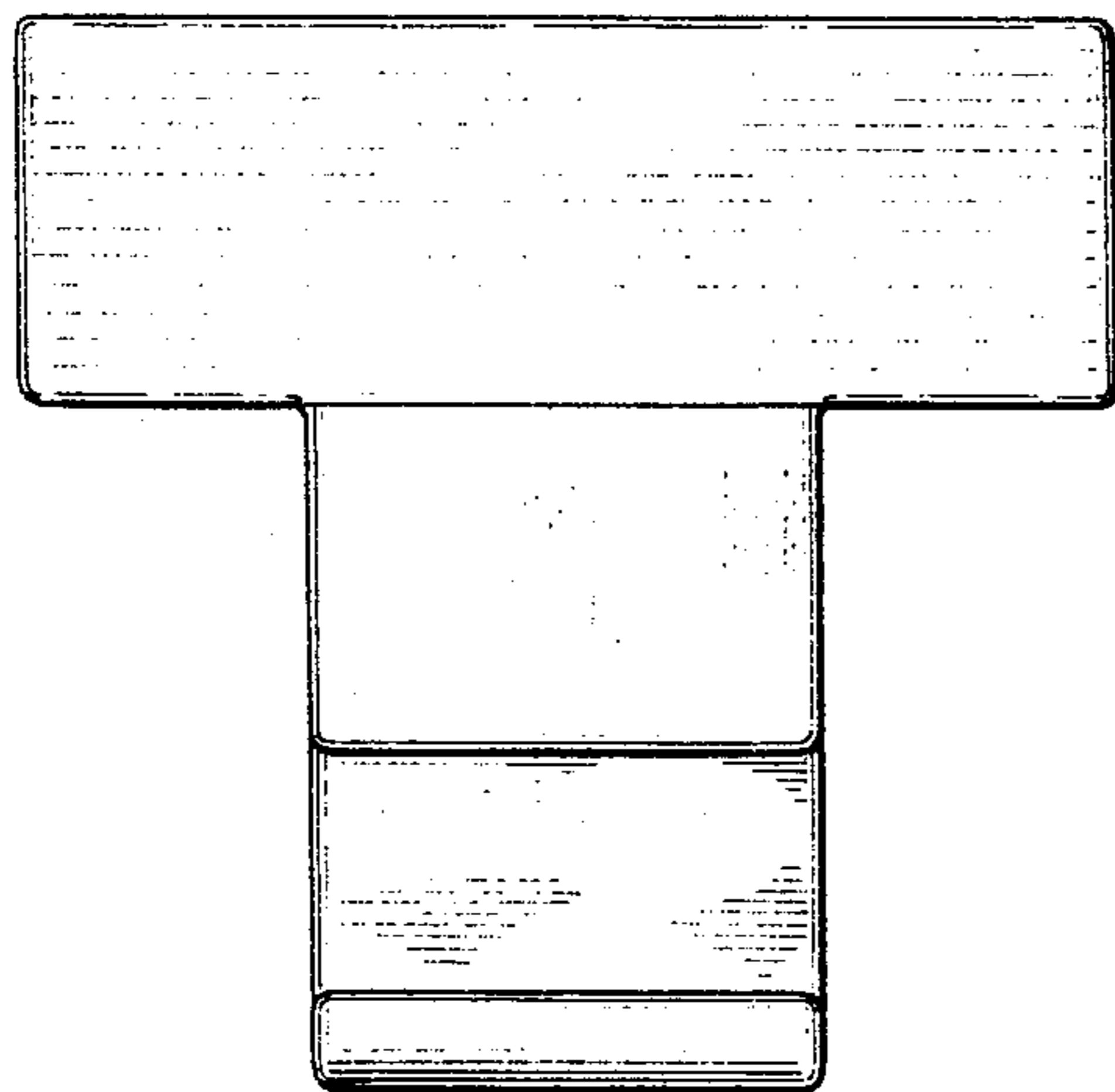
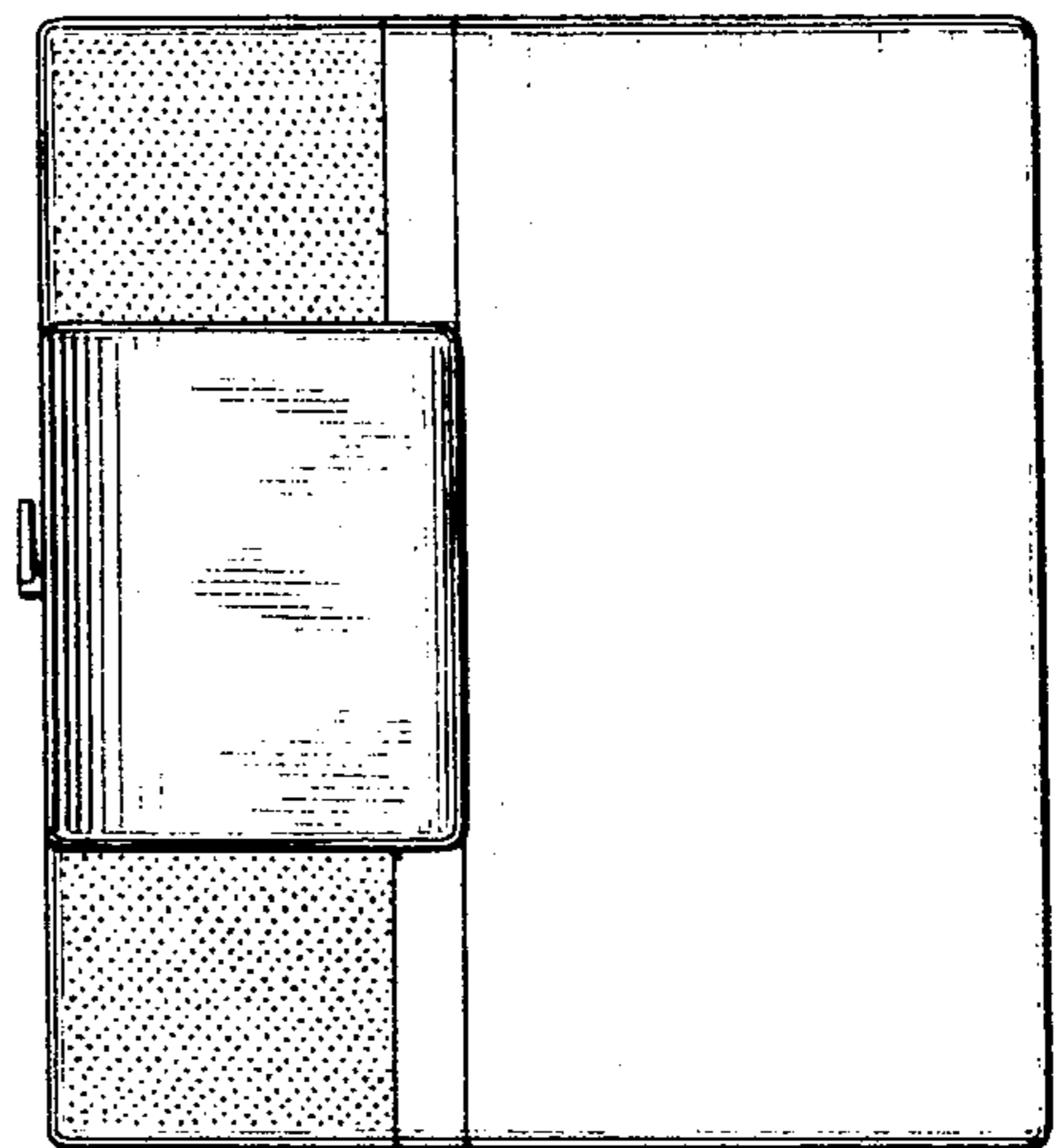

FIG. 6

FIG. 7

