

[54] MOTORCYCLE INSTRUMENT CLUSTER

[75] Inventors: Nakamura Akira, Tokyo; Yamada Toshiyuki, Saitama, both of Japan

[73] Assignee: Honda Giken Kogyo Kabushiki Kaisha, Japan

[**] Term: 14 Years

[21] Appl. No.: 450,451

[22] Filed: Dec. 16, 1982

[30] Foreign Application Priority Data

Jun. 22, 1982 [JP] Japan 57-28088

[52] U.S. Cl. D12/192; D10/98

[58] Field of Search D12/192, 114; D10/53, D10/98, 102, 122-126; 73/431, 432 AD; 116/300; 180/90; 280/289 R, 289 H; 235/95 R

[56] References Cited

U.S. PATENT DOCUMENTS

D. 261,752 11/1981 Iwakura D10/98

OTHER PUBLICATIONS

Cycle World, 3/78, p. 91, Instrument Cluster, center right side of page.

Cycle World, 12/81, p. 33, Instrument Cluster, top left side of page.

Primary Examiner—James M. Gandy
Attorney, Agent, or Firm—Kane, Dalsimer, Kane, Sullivan and Kurucz

[57] CLAIM

The ornamental design for a motorcycle instrument cluster, as shown and described.

DESCRIPTION

FIG. 1 is a front elevational view of a motorcycle instrument cluster;
FIG. 2 is a right side elevational view thereof;
FIG. 3 is a left side elevational view thereof;
FIG. 4 is a top plan view thereof;
FIG. 5 is a bottom plan view thereof; and
FIG. 6 is a rear elevational view thereof.

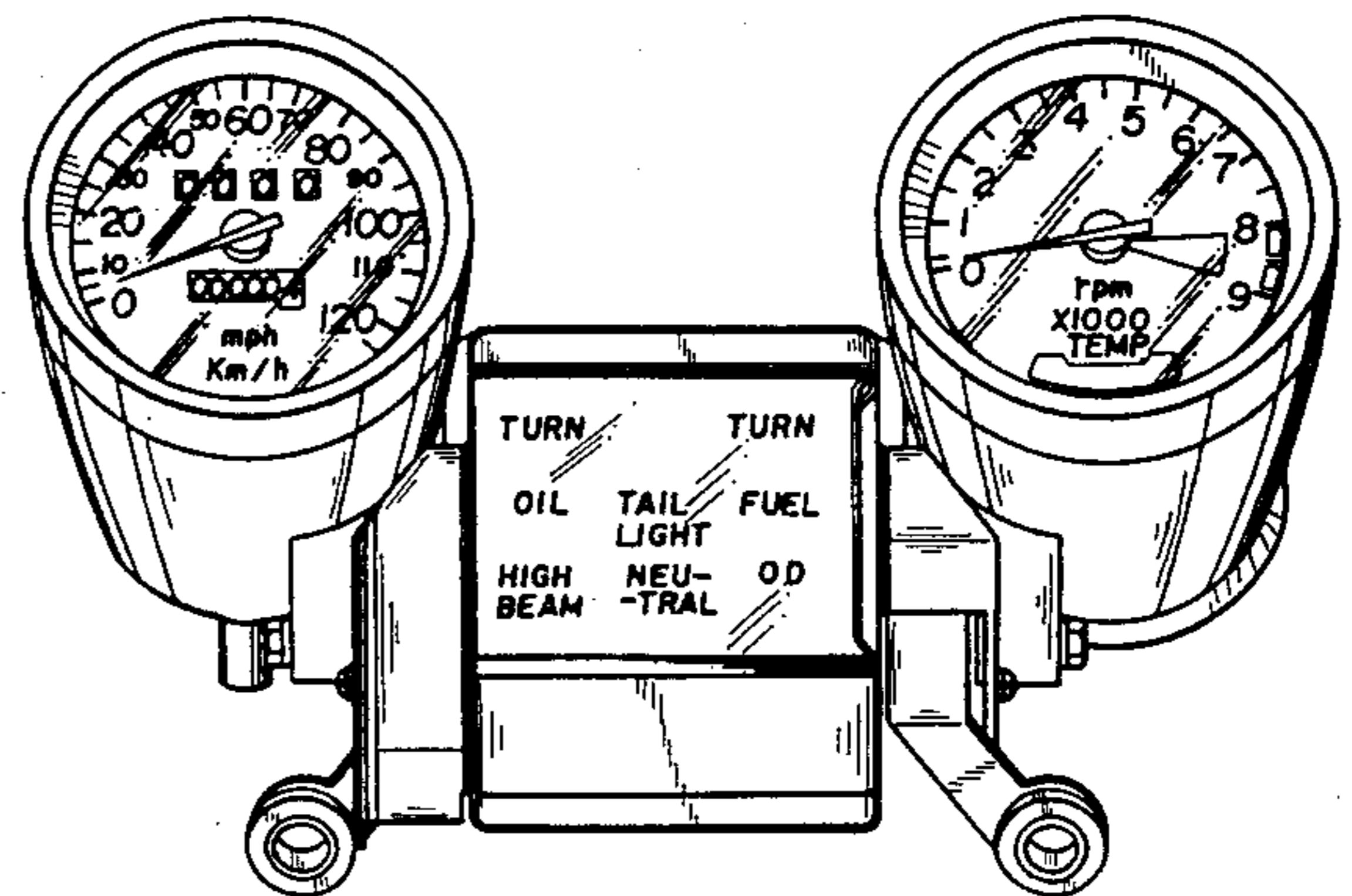
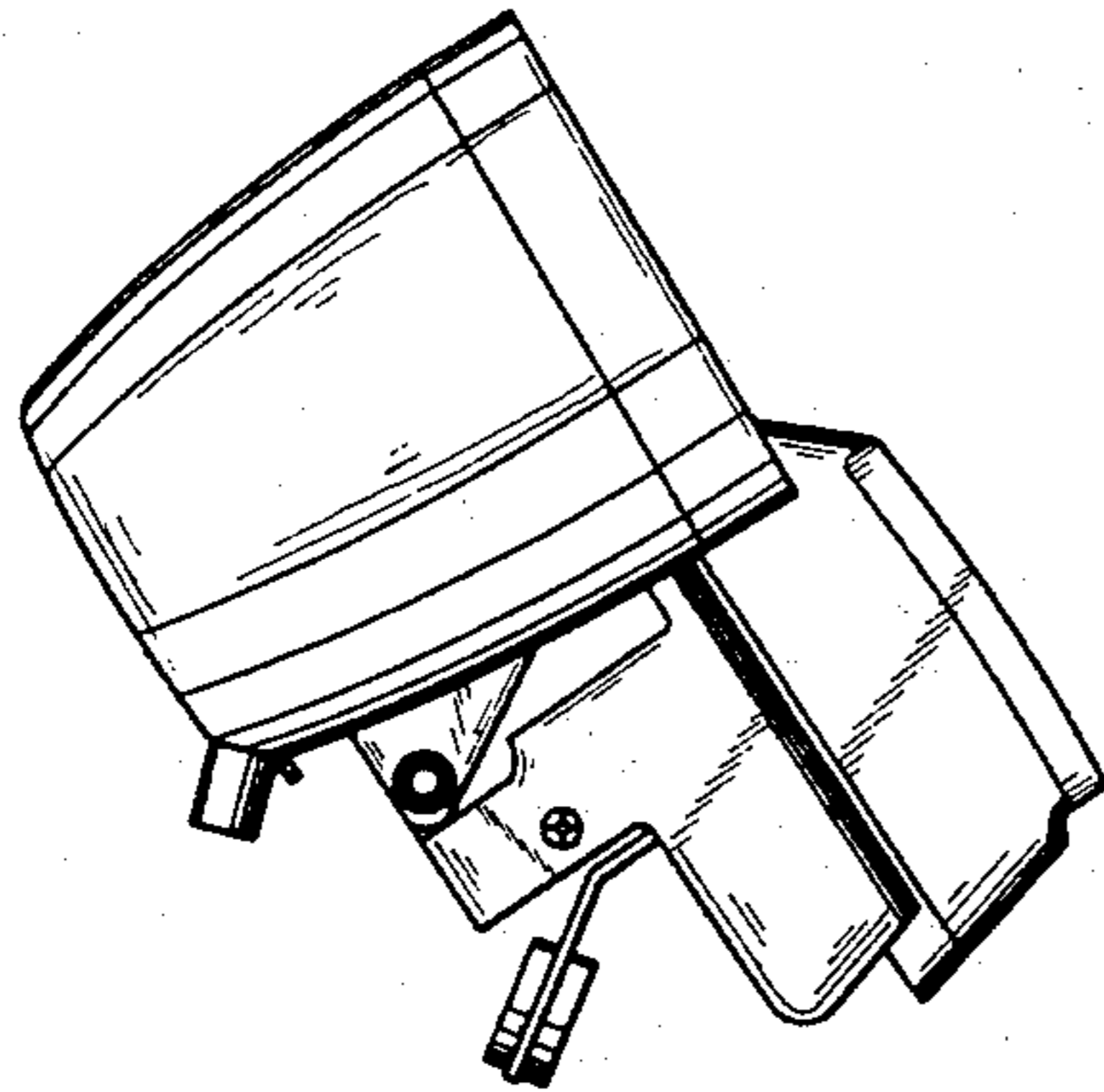

FIG. 1

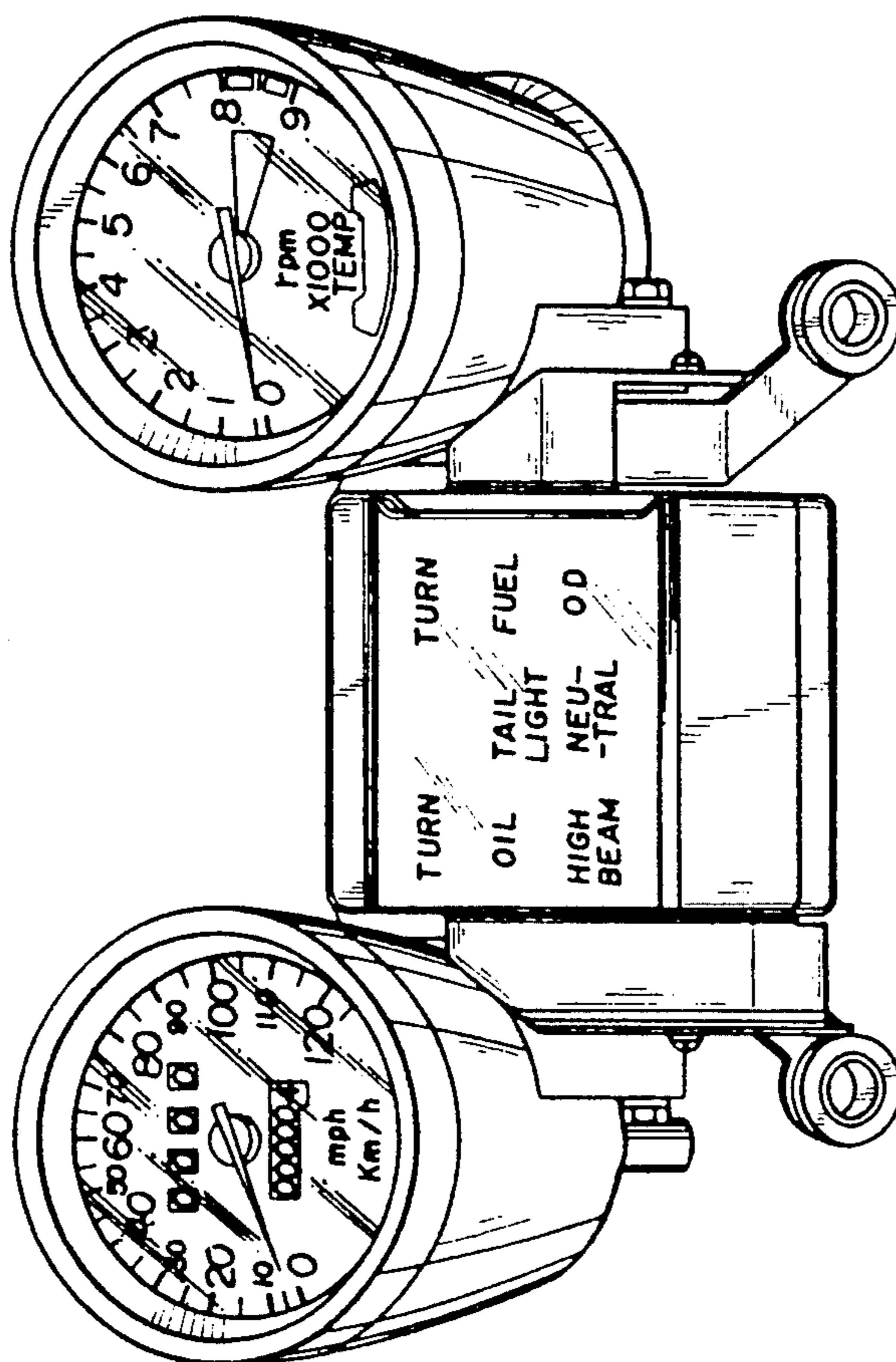

FIG. 3

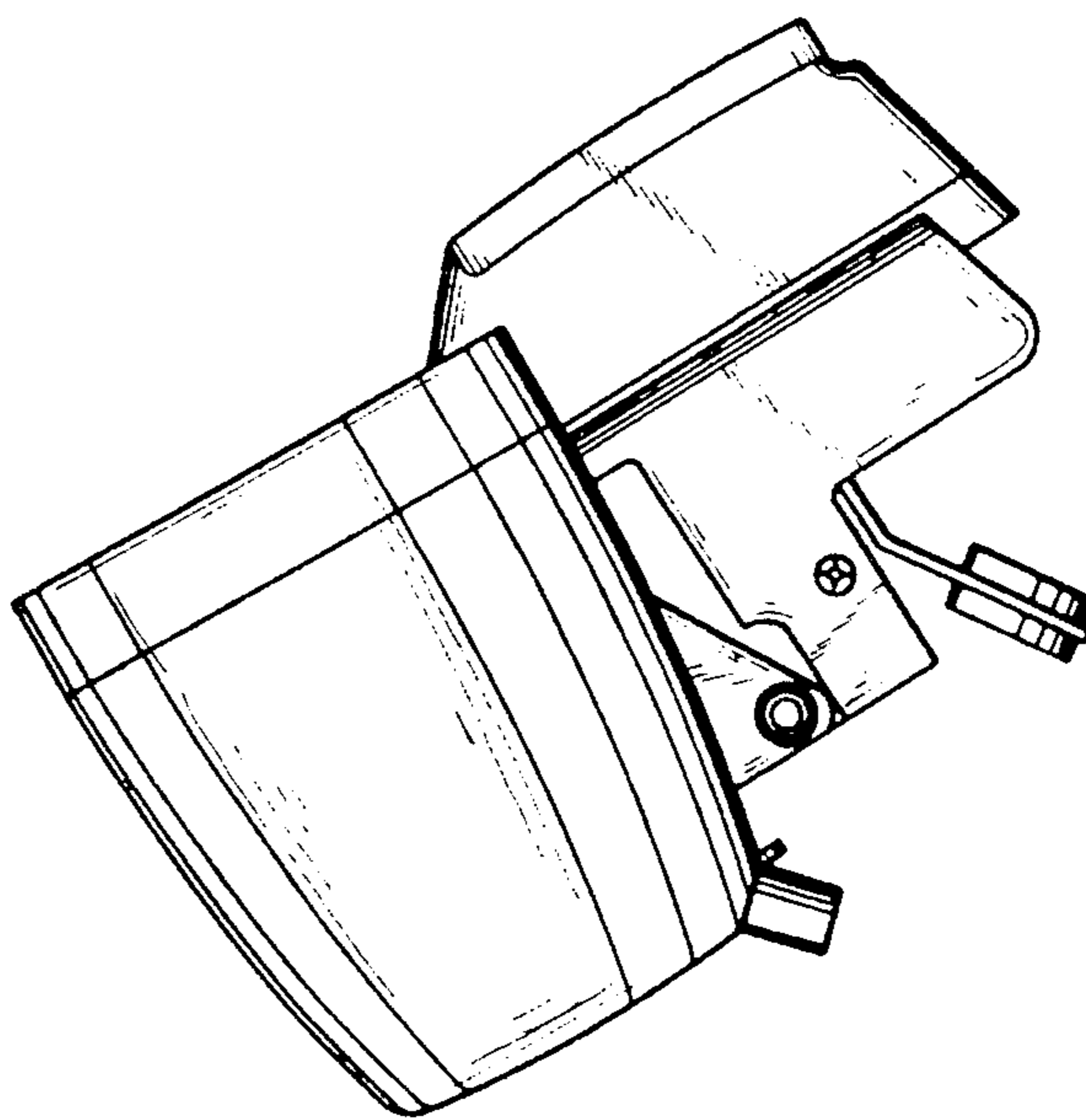

FIG. 2

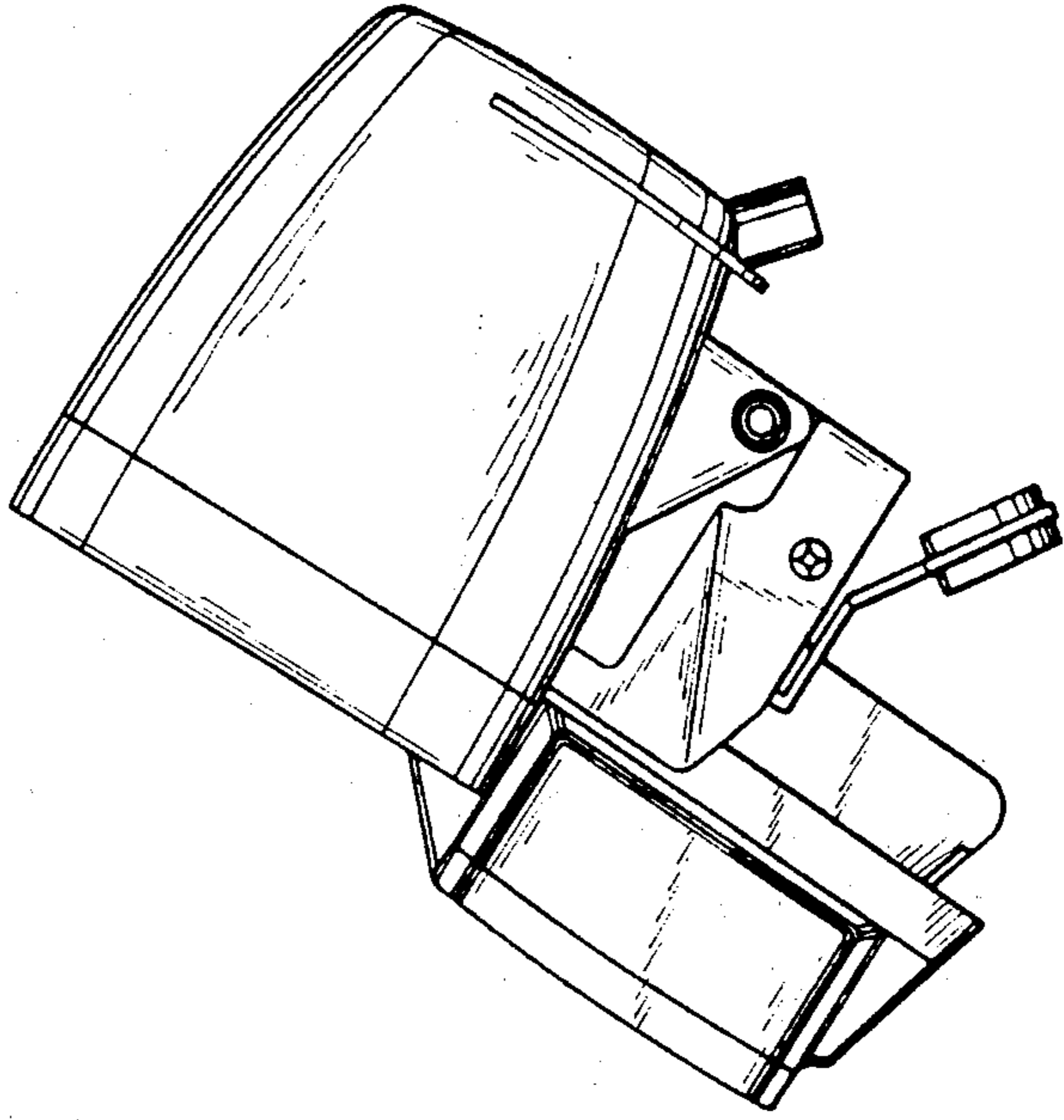

FIG. 6

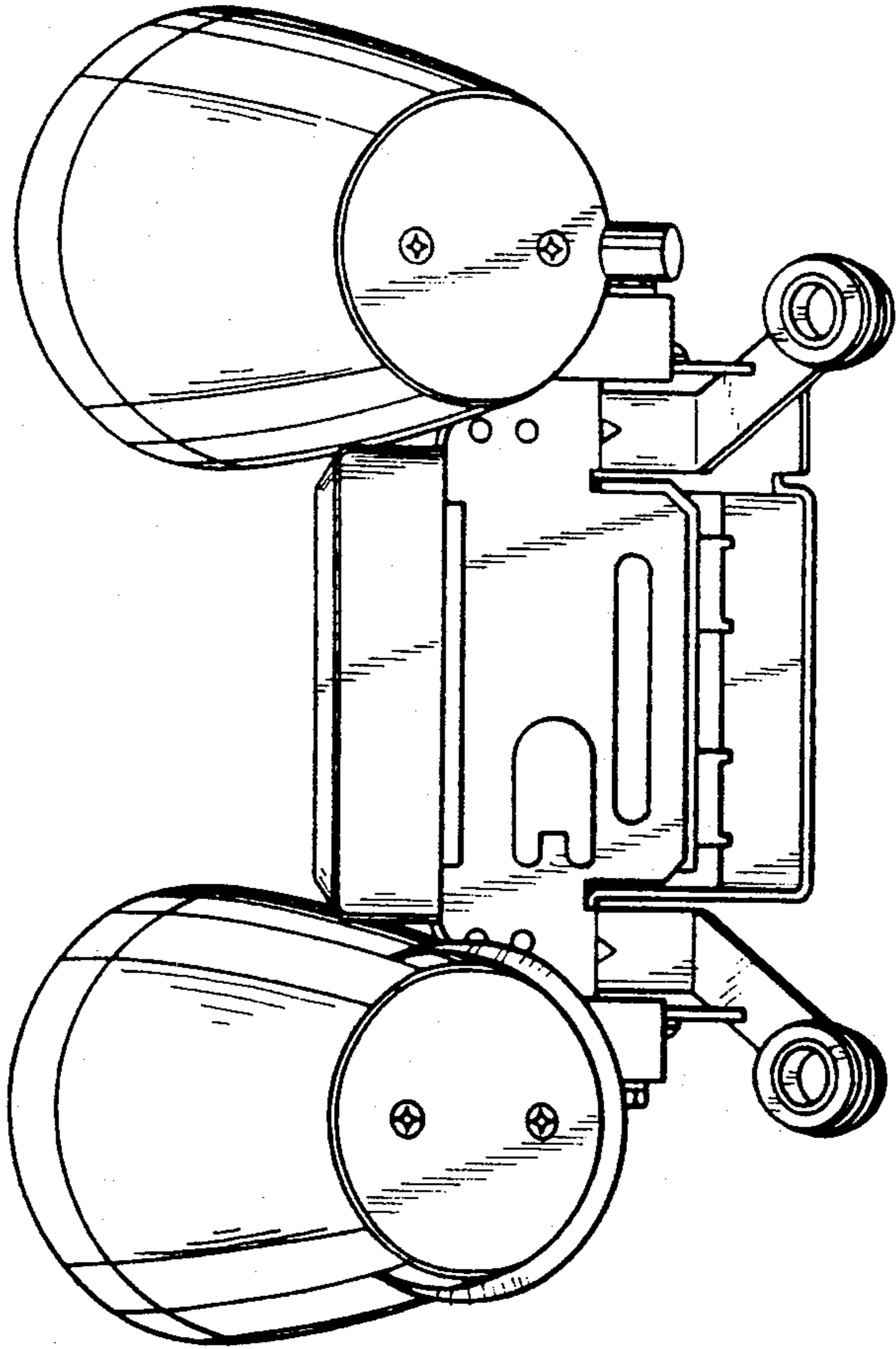

FIG. 4

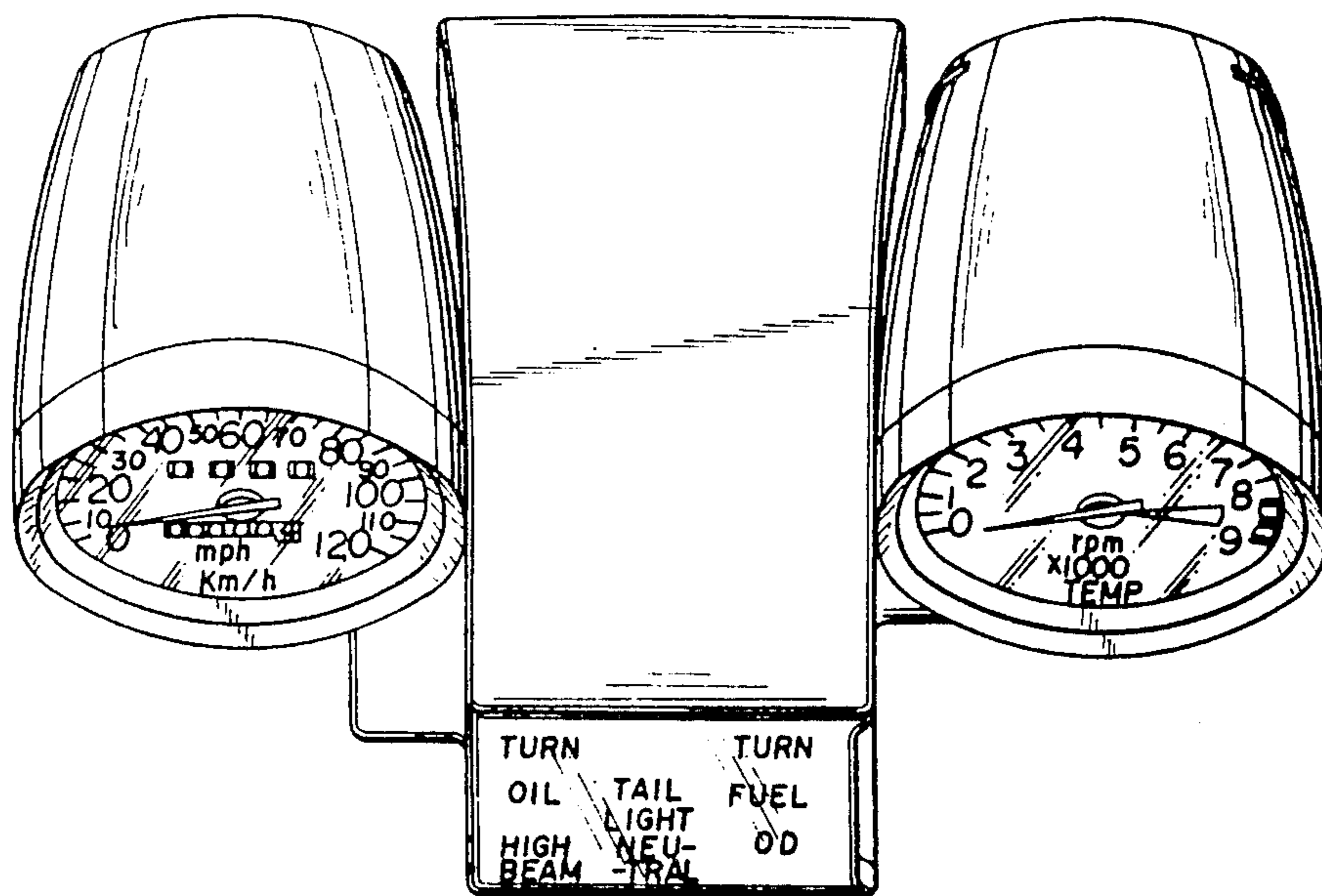

FIG. 5

