

[54] **THERMOMETER FOR VEHICLES**

[75] **Inventor: Yoshihisa Tanaka, Ichikawa, Japan**

[73] **Assignee: Tanaka Manufacturing Co., Ltd.,
Tokyo, Japan**

[**] **Term: 14 Years**

[21] **Appl. No.: 458,856**

[22] **Filed: Jan. 17, 1983**

[30] **Foreign Application Priority Data**

Sep. 21, 1982 [JP] Japan 57-43054

[52] **U.S. Cl. D10/57; D10/123**

[58] **Field of Search D10/57, 58, 60; 73/431;
374/170, 171; 340/753, 754**

[56] **References Cited**

U.S. PATENT DOCUMENTS

D. 240,024	5/1976	Riley	D10/57
D. 240,607	7/1976	Riley	D10/57
D. 243,512	3/1977	VanKersen	D10/57
D. 269,164	5/1983	O'Driscoll	D10/57 X
4,306,233	12/1981	Westbrook	340/753

Primary Examiner—Nelson C. Holtje

[57] **CLAIM**

The ornamental design for thermometer for vehicles, as shown.

DESCRIPTION

FIG. 1 is a top and left front perspective view of a thermometer for vehicles showing my new design;
FIG. 2 is a bottom plan view thereof;
FIG. 3 is a front elevational view thereof;
FIG. 4 is a right side elevational view thereof;
FIG. 5 is a rear elevational view thereof.

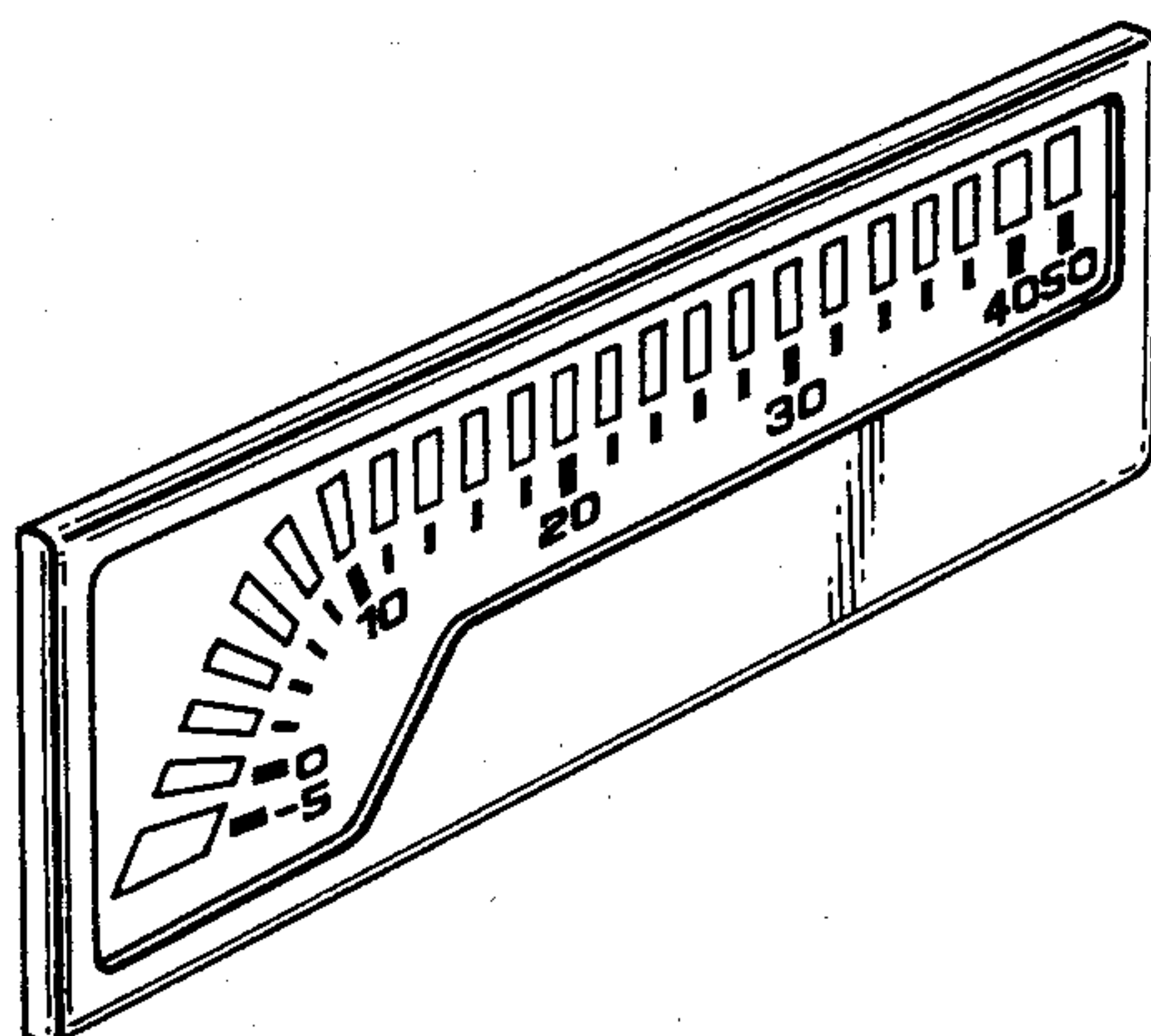

FIG. 1

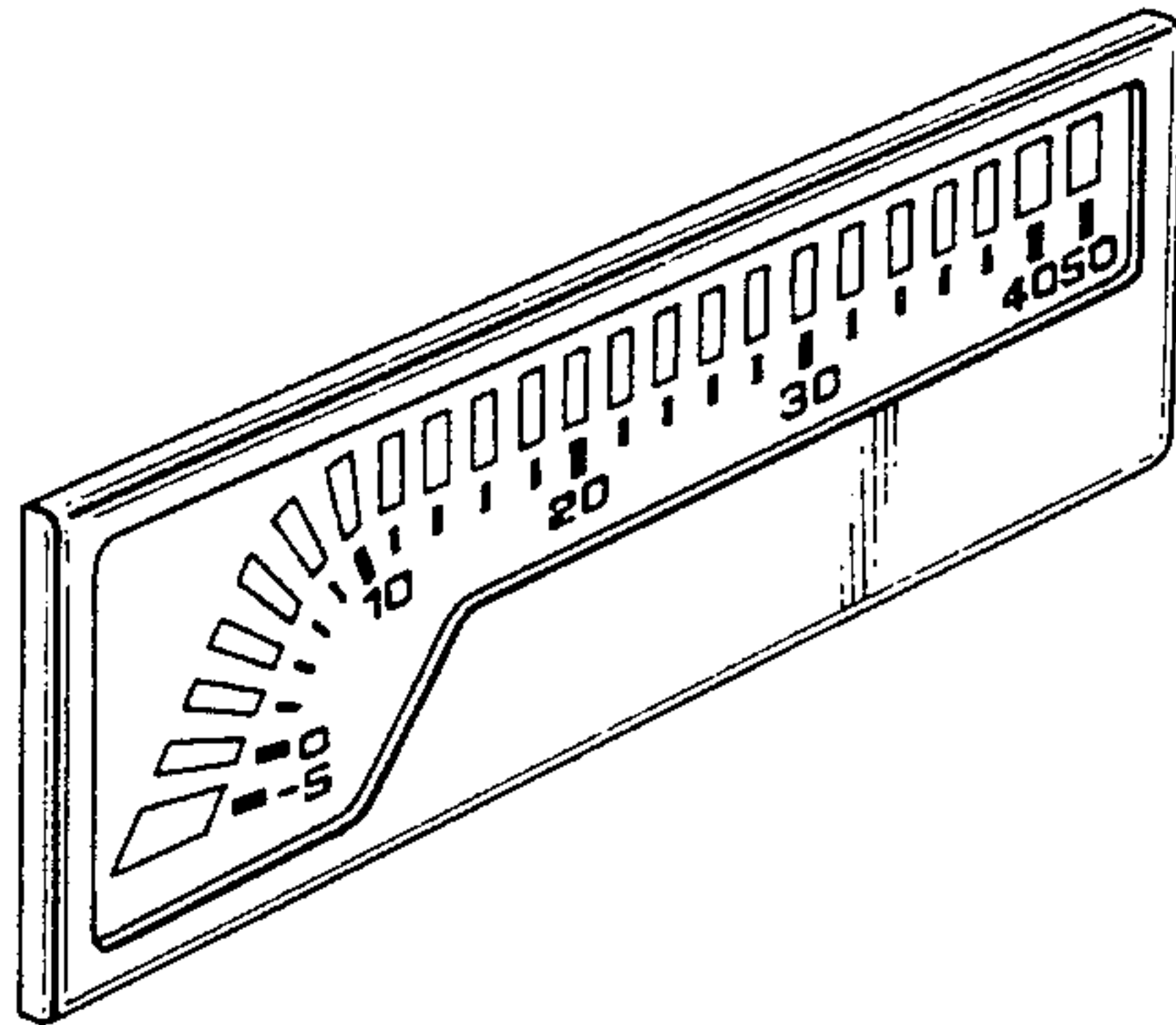

FIG. 2

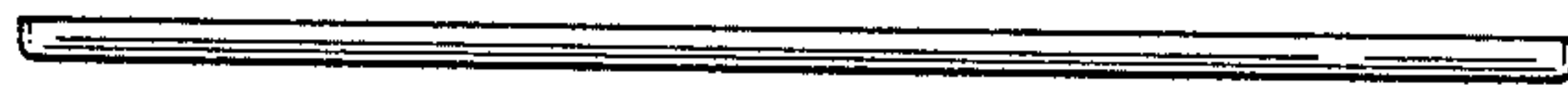

FIG. 3

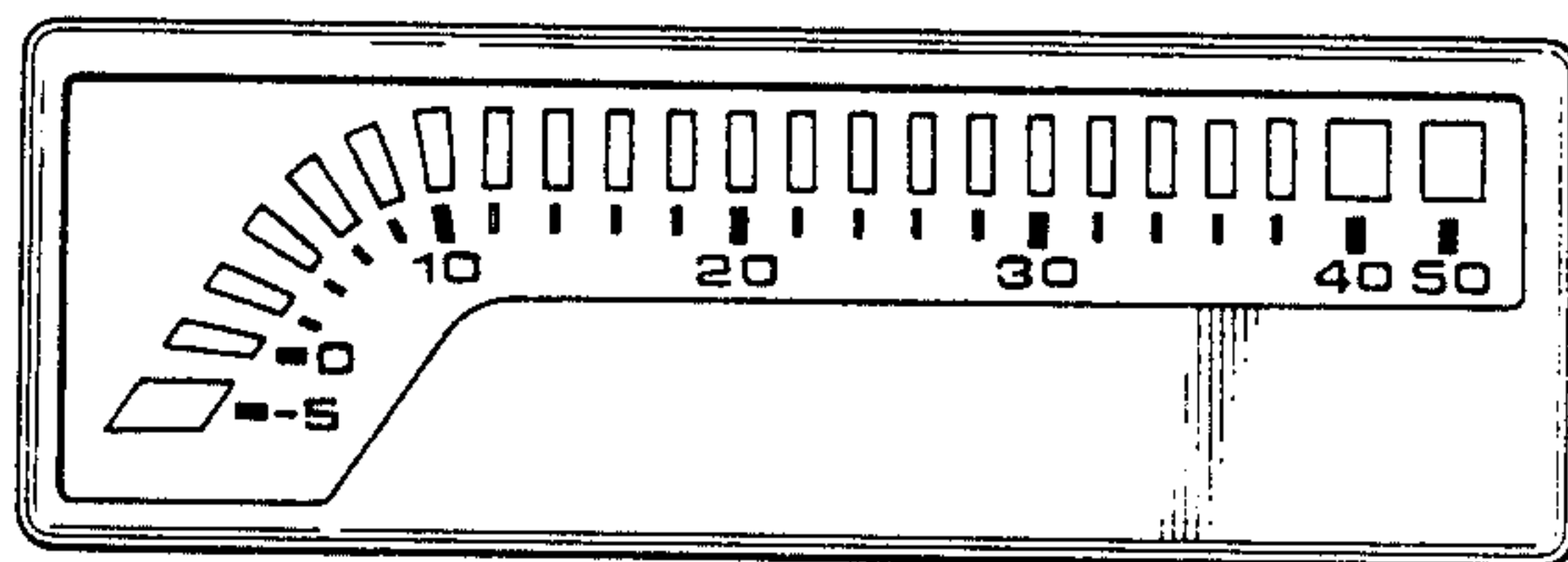

FIG. 4



FIG. 5

