

United States Patent [19]

Akazawa et al.

[11] Patent Number: **Des. 279,957**

[45] Date of Patent: **** Aug. 6, 1985**

[54] DRIVER DRILL

[75] Inventors: **Shumi Akazawa, Fuchu; Kiyoshi Hoshino, Tokyo, both of Japan**

[73] Assignee: **Ryobi Limited, Hiroshima, Japan**

[**] Term: **14 Years**

[21] Appl. No.: **546,988**

[22] Filed: **Oct. 31, 1983**

[30] Foreign Application Priority Data

May 7, 1983 [JP] Japan 58-19173

[52] U.S. Cl. **D8/61; D8/68**

[58] Field of Search D8/30, 61, 68, 107, D8/51; 173/163, 169, 170; 81/54, 57.11; 408/124, DIG. 1; 310/50; 222/146 HE; 219/230, 421; 72/391, 453.15

[56] References Cited

U.S. PATENT DOCUMENTS

D. 246,946 1/1978 Schultz D8/68

2,829,285 4/1958 Steiner et al. 173/163 X
3,584,695 6/1971 Turnbull 81/54 X
3,652,879 3/1972 Plunkett et al. 408/124 X

Primary Examiner—Susan J. Lucas

Assistant Examiner—C. E. Heflin

Attorney, Agent, or Firm—Frishauf, Holtz, Goodman & Woodward

[57] CLAIM

The ornamental design for a driver drill, as shown and described.

DESCRIPTION

FIG. 1 is a front elevational view of a driver drill showing our new design;
FIG. 2 is a rear elevational view thereof;
FIG. 3 is a right side elevational view thereof;
FIG. 4 is a left side elevational view thereof;
FIG. 5 is a top plan view thereof;
FIG. 6 is a bottom plan view thereof;
FIG. 7 is a front-left side perspective view thereof; and
FIG. 8 is a rear-right side perspective view thereof.

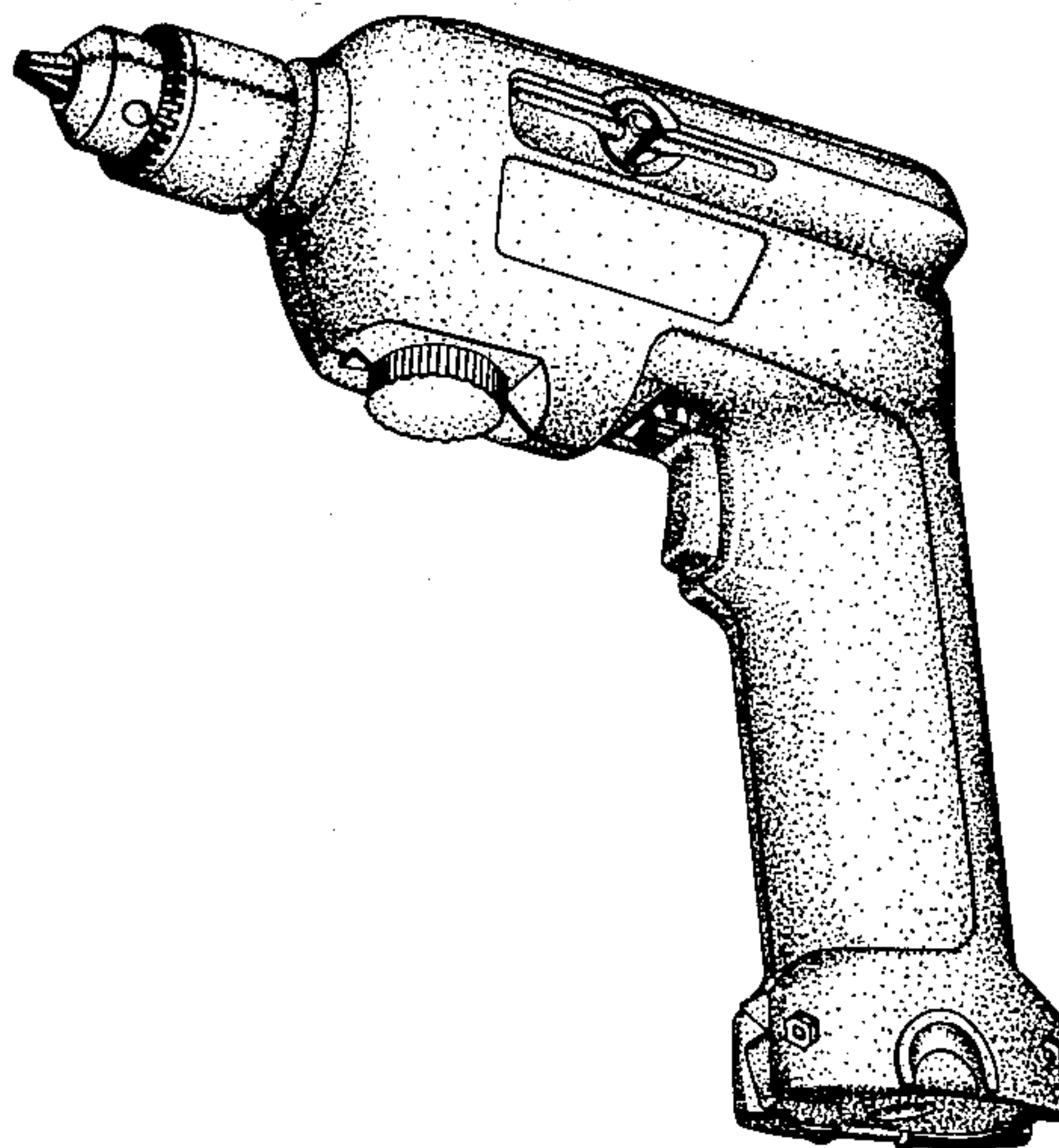

FIG. 1

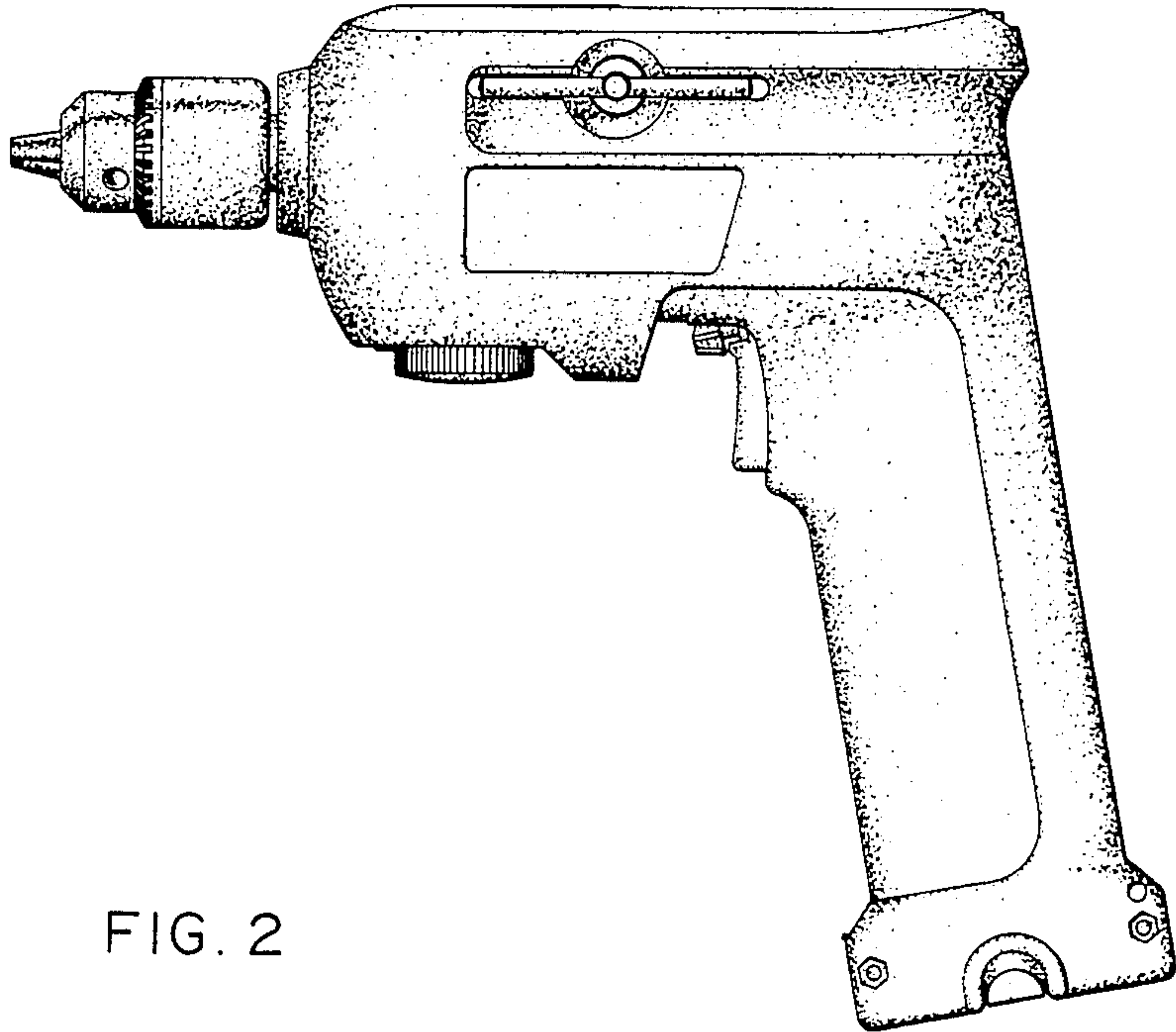

FIG. 2

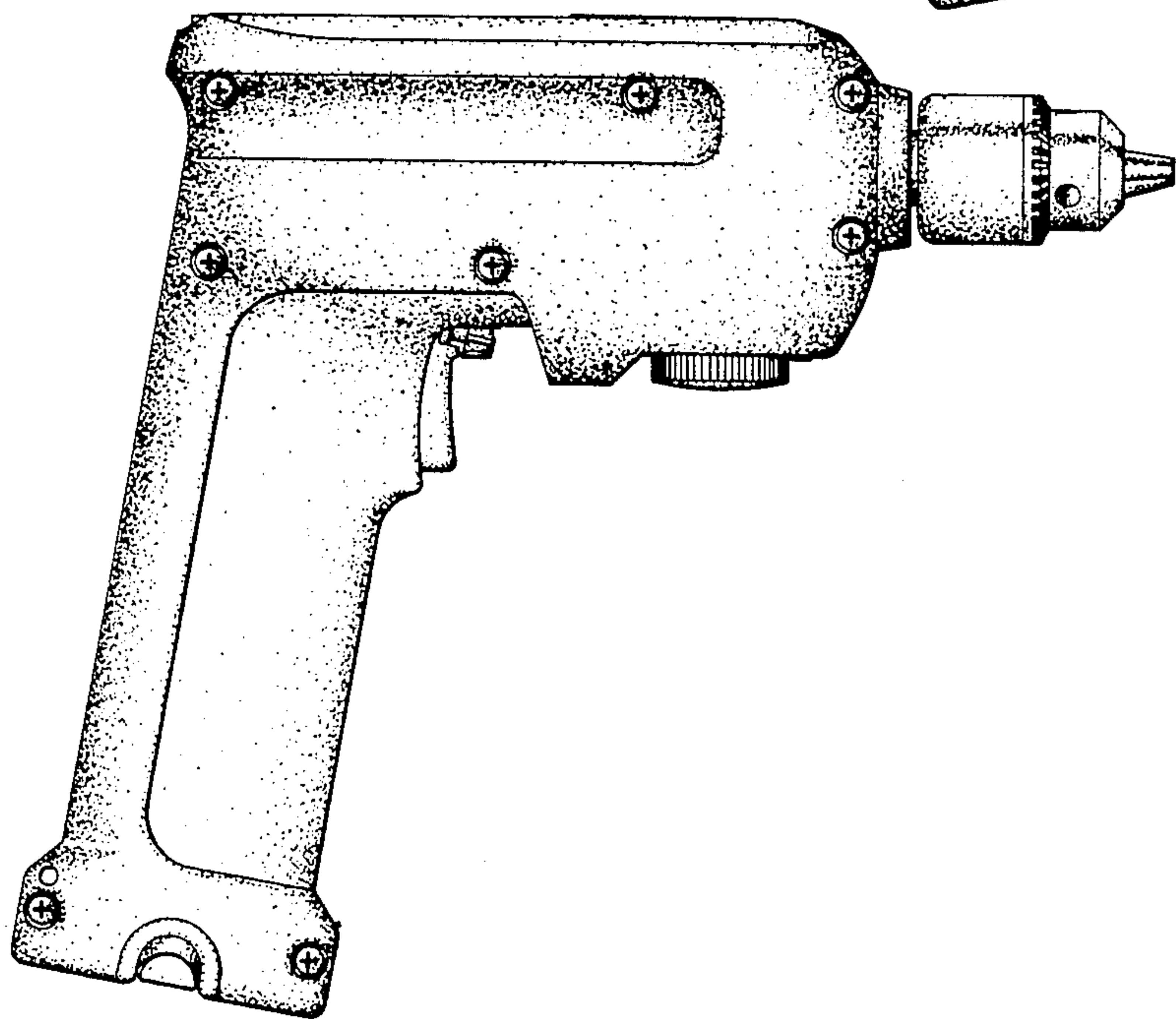

FIG. 4

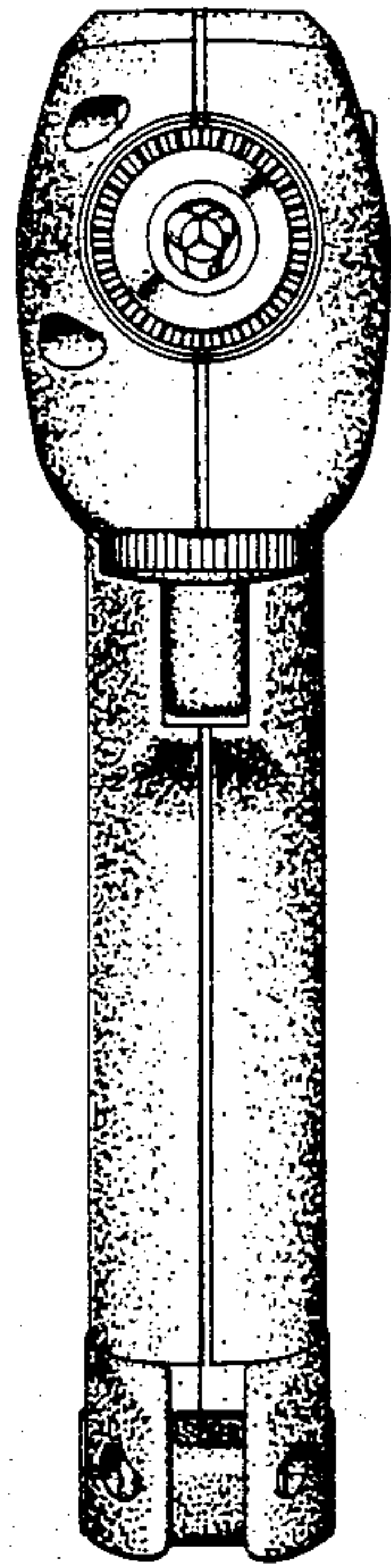

FIG. 3

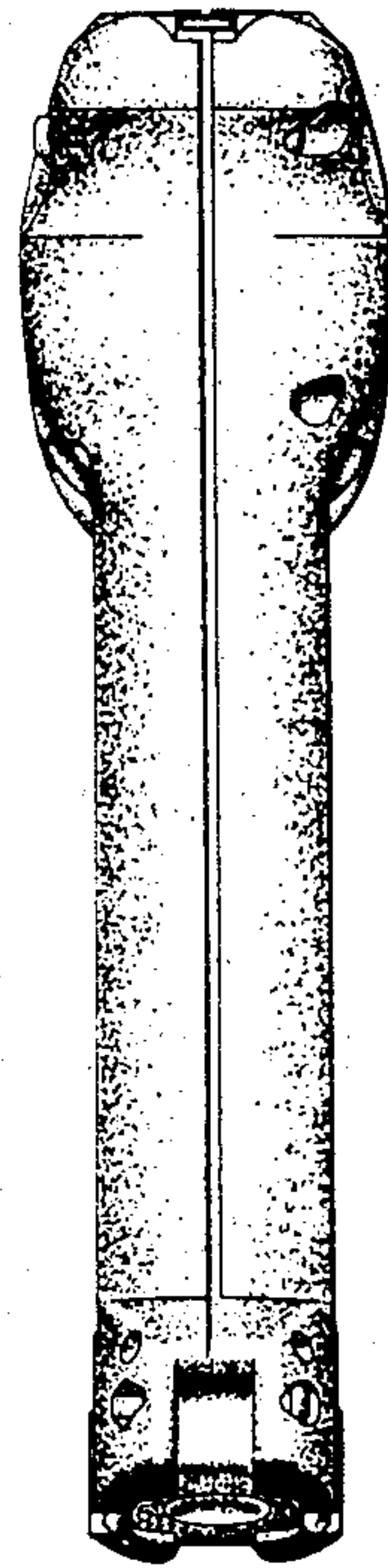

FIG. 5

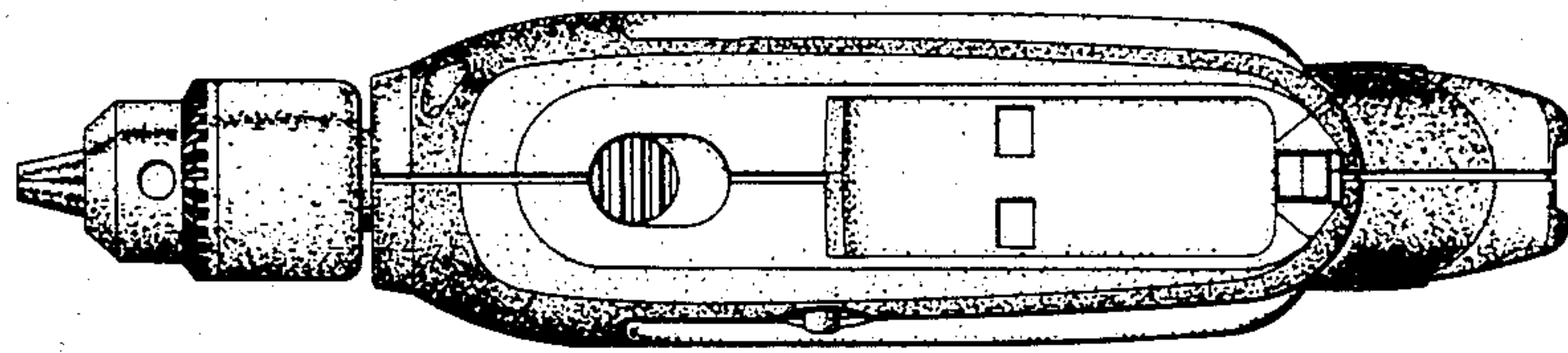

FIG. 6

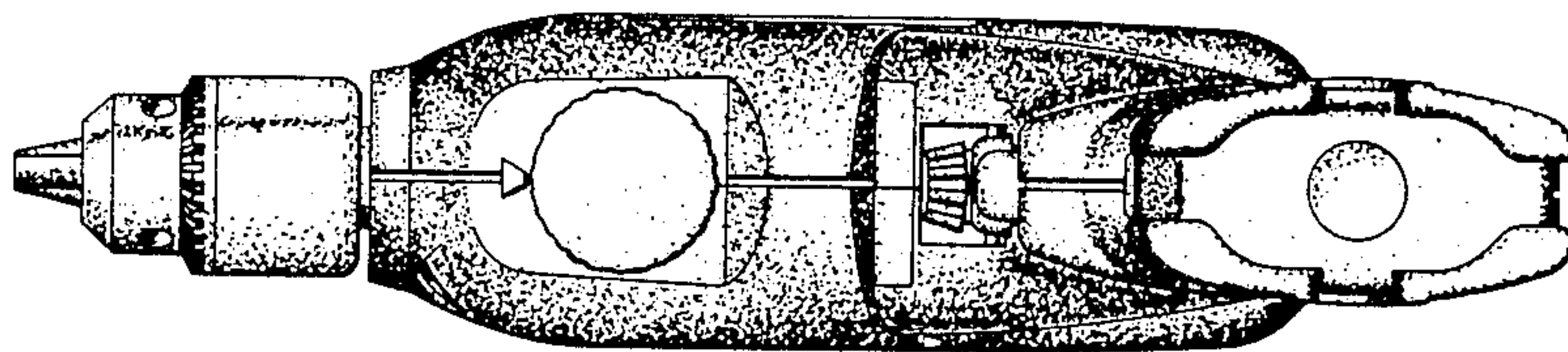

FIG. 7

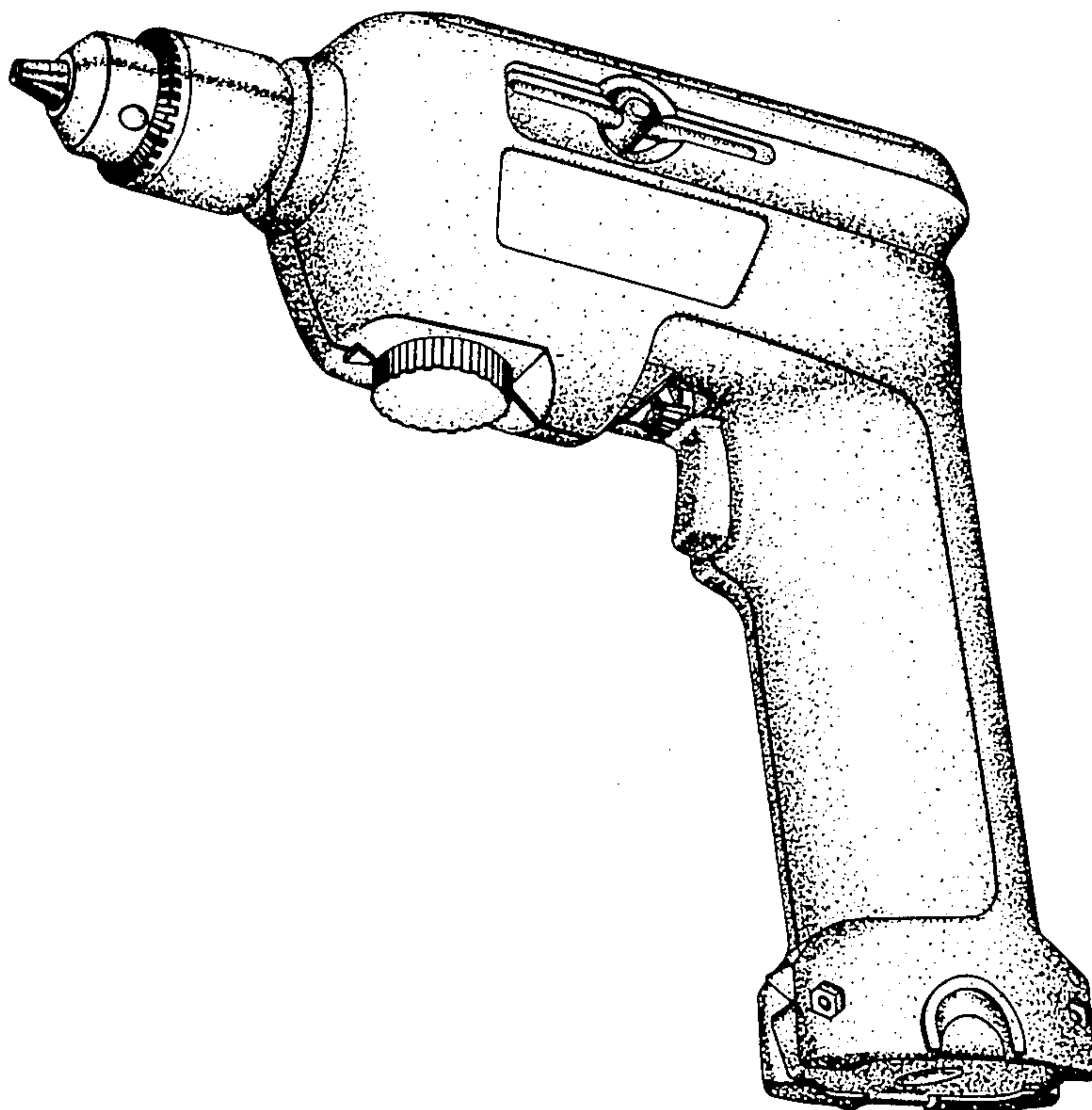

FIG. 8

