

United States Patent [19]

Wiese

[11] Patent Number: **Des. 279,908**

[45] Date of Patent: **** Jul. 30, 1985**

[54] **CIGARETTE PACK MERCHANDISING UNIT**

[75] Inventor: **Lee Wiese, Upper Nyack, N.Y.**

[73] Assignee: **Philip Morris Incorporated, New York, N.Y.**

[**] Term: **14 Years**

[21] Appl. No.: **464,607**

[22] Filed: **Feb. 8, 1983**

[52] U.S. Cl. **D20/4**

[58] Field of Search **D20/4, 1-9;**
211/59.2, 59.4, 133, 187, 207; 221/92, 282, 123,
124, 126, 131, 133; 312/42, 60, 283

[56] **References Cited**

U.S. PATENT DOCUMENTS

D. 201,330 6/1965 Kolstad **D20/4 X**

2,683,642 7/1954 Stoleson 312/283 X
3,172,713 3/1965 Rupert 312/42 X
3,858,757 1/1975 Langdon, Jr. 221/92
3,993,372 11/1976 Mihos 312/42
4,478,338 10/1984 Crosslen 211/59.2

Primary Examiner—Bernard Ansher
Assistant Examiner—Linda Titolo
Attorney, Agent, or Firm—Jeffrey H. Ingerman

[57] **CLAIM**

The ornamental design for a cigarette pack merchandising unit, as shown.

DESCRIPTION

FIG. 1 is a front perspective view of a cigarette pack merchandising unit showing my new design; FIG. 2 is a top plan view thereof; FIG. 3 is a right side elevational view thereof; and FIG. 4 is a rear elevational view thereof.

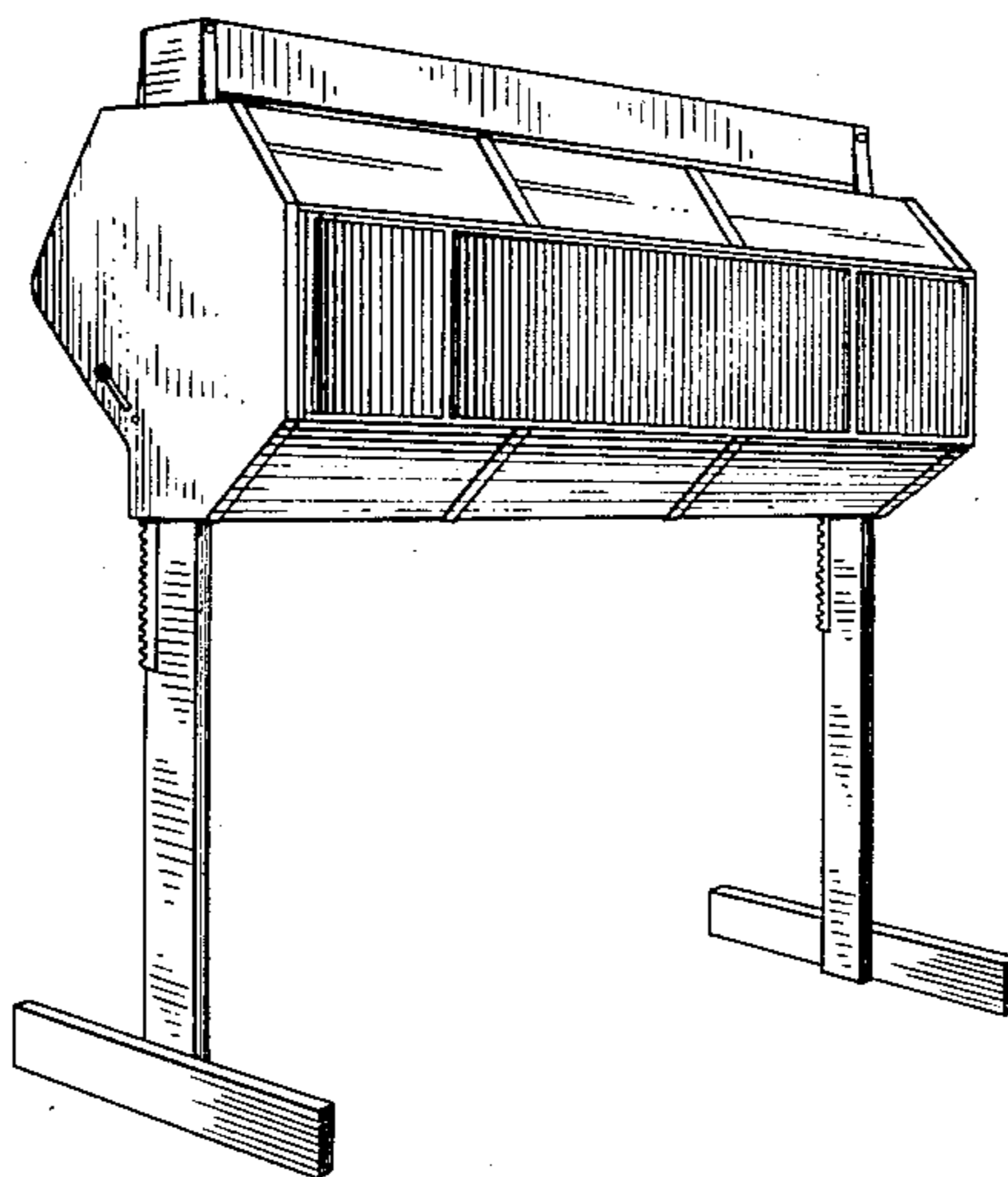

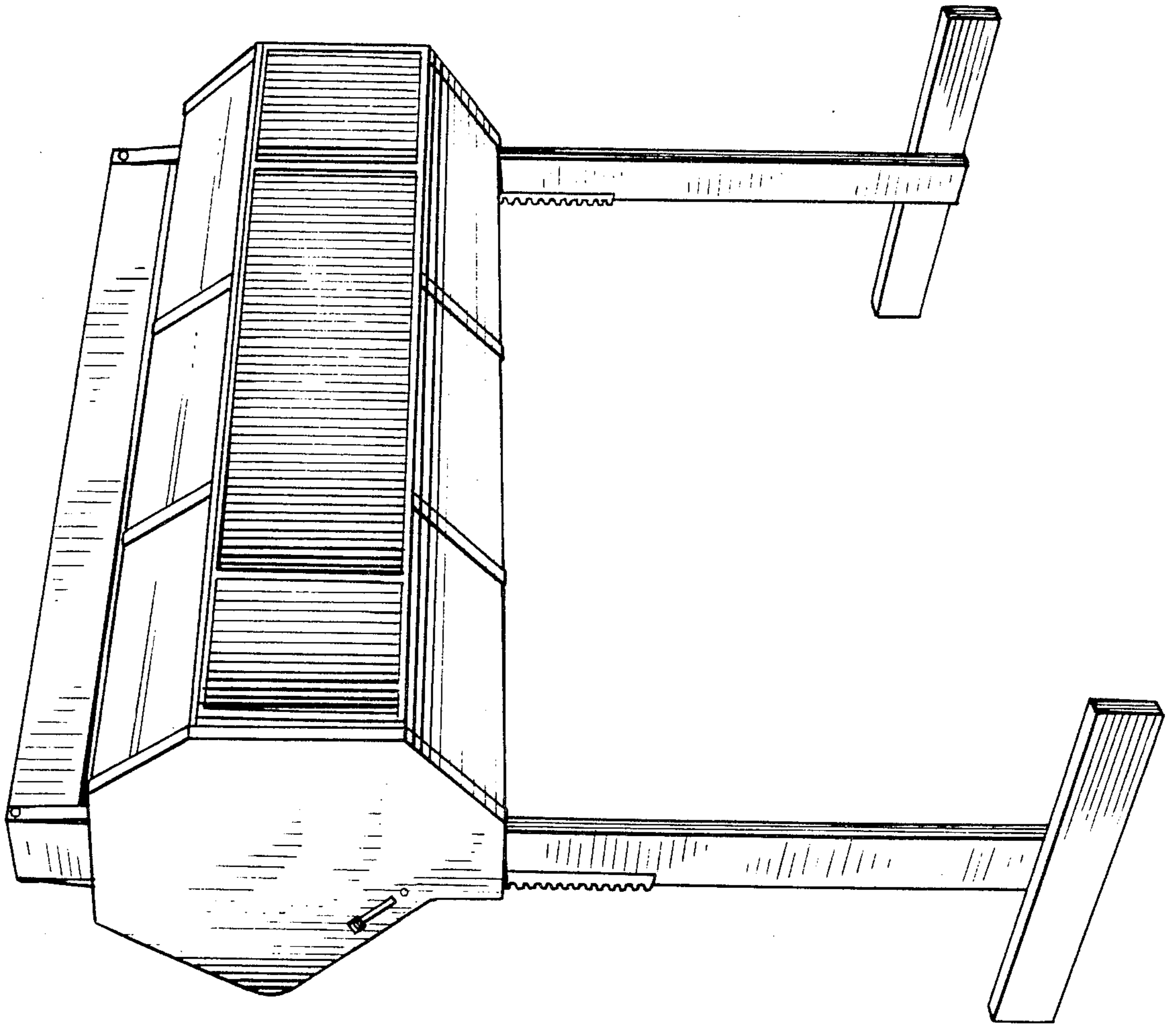
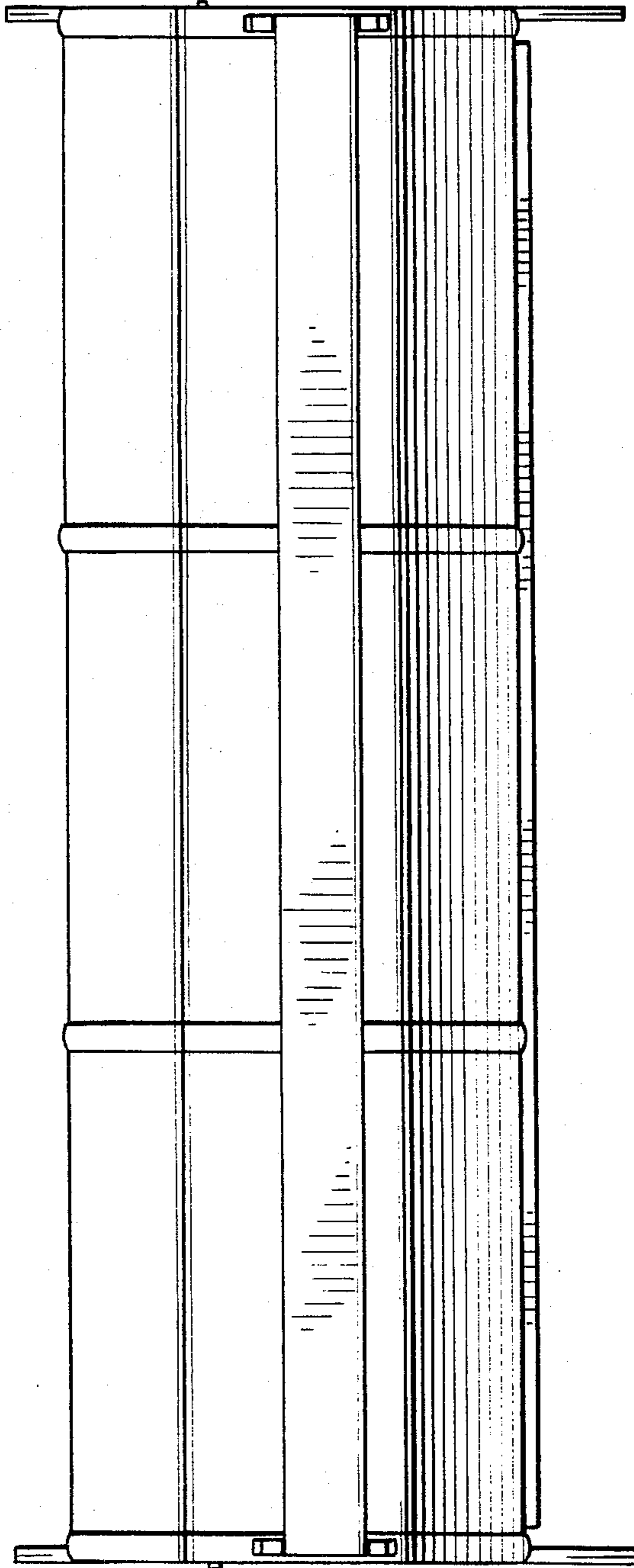

Fig. 1.

FIG. 2.



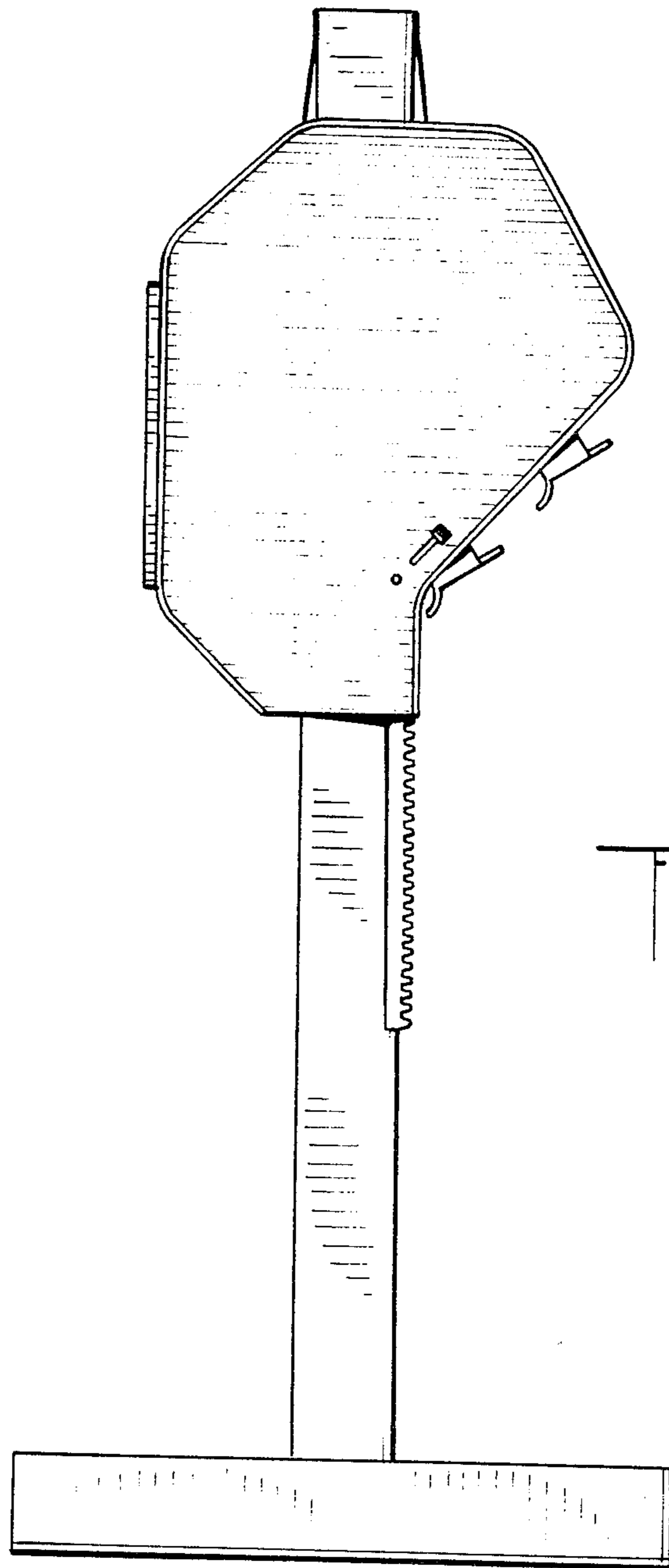

Fig. 3.

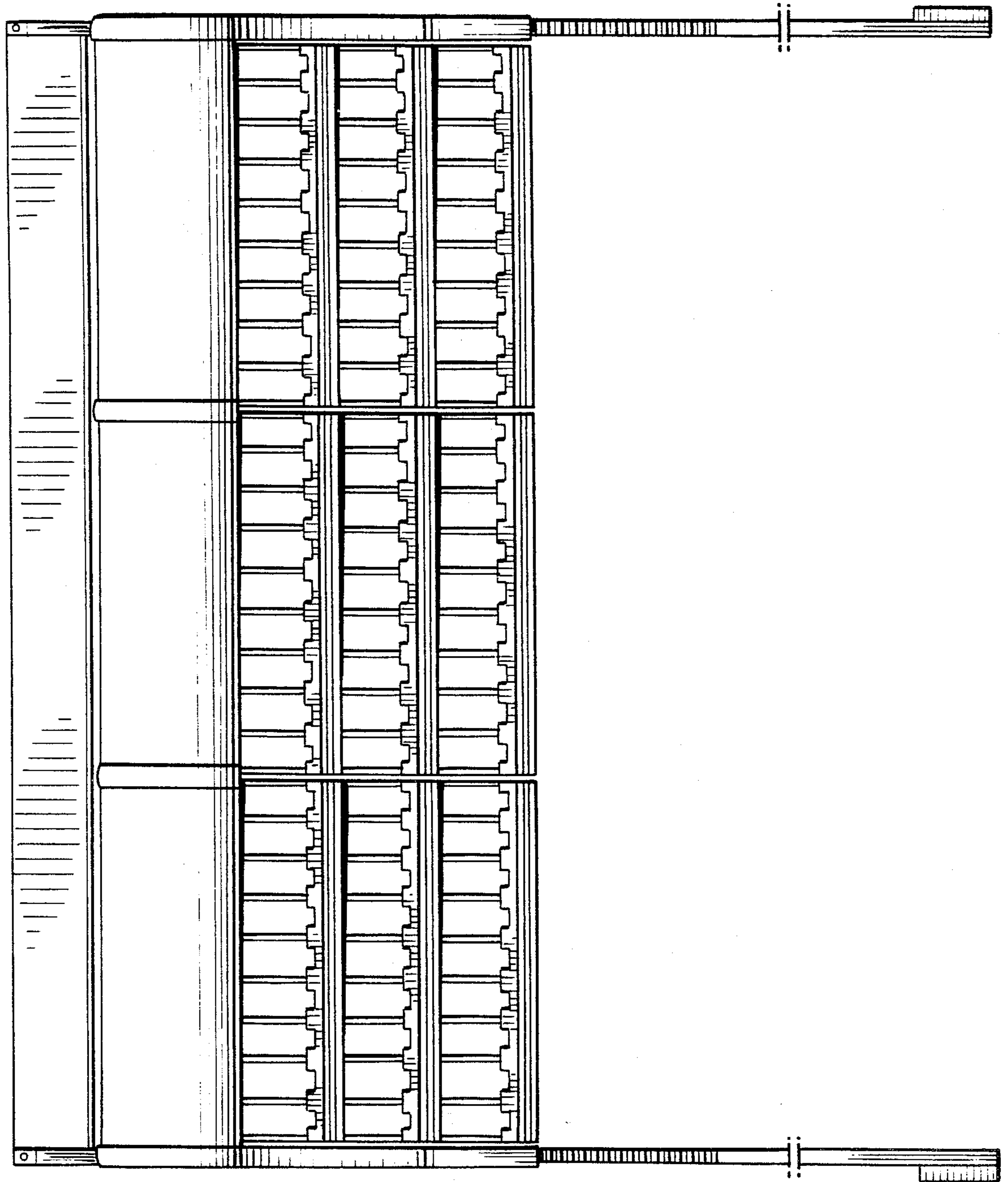

Fig. 4.