

[54] TOY SPACE VEHICLE

[75] Inventors: Carl M. Stern; Karl D. Lerch, both of East Aurora, N.Y.

[73] Assignee: The Quaker Oats Company, Chicago, Ill.

[**] Term: 14 Years

[21] Appl. No.: 461,458

[22] Filed: Jan. 27, 1983

[52] U.S. Cl. D21/128; D21/134; D21/136

[58] Field of Search D21/71, 76, 77, 78, D21/79, 87, 124, 128, 134, 136, 137; 446/71, 431, 435, 436, 437, 439, 443, 447, 448, 451, 454, 460, 465

[56] References Cited

U.S. PATENT DOCUMENTS

- D. 219,668 1/1971 King et al. D21/76
- D. 269,689 7/1983 Ohkado D21/128

D. 274,634 7/1984 Terui et al. D21/136

OTHER PUBLICATIONS

Hong Kong Toys-1982, p. 136, Toy Vehicles, "Explorer 1" & Explorer 2.

Hong Kong Toys-1982, p. 183, Toy Vehicle near center of page.

Primary Examiner—Charles A. Rademaker
Attorney, Agent, or Firm—Cumpston & Shaw

[57] CLAIM

The ornamental design for a toy space vehicle, substantially as shown and described.

DESCRIPTION

FIG. 1 is a front elevational view of a toy space vehicle showing our new design;

FIG. 2 is a left side elevational view thereof;

FIG. 3 is a rear elevational view thereof;

FIG. 4 is a right side elevational view thereof;

FIG. 5 is a top plan view thereof; and

FIG. 6 is a bottom plan view thereof.

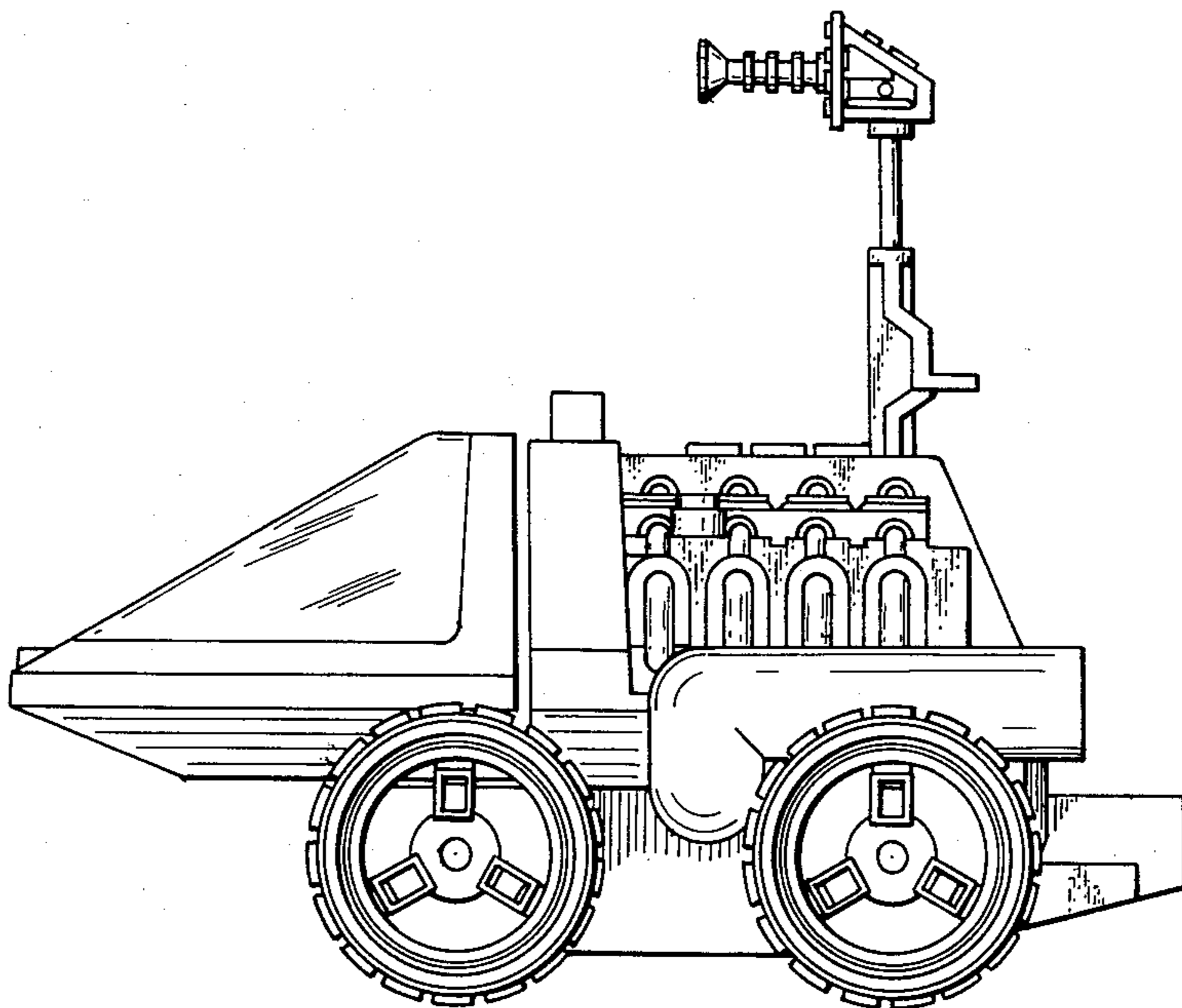

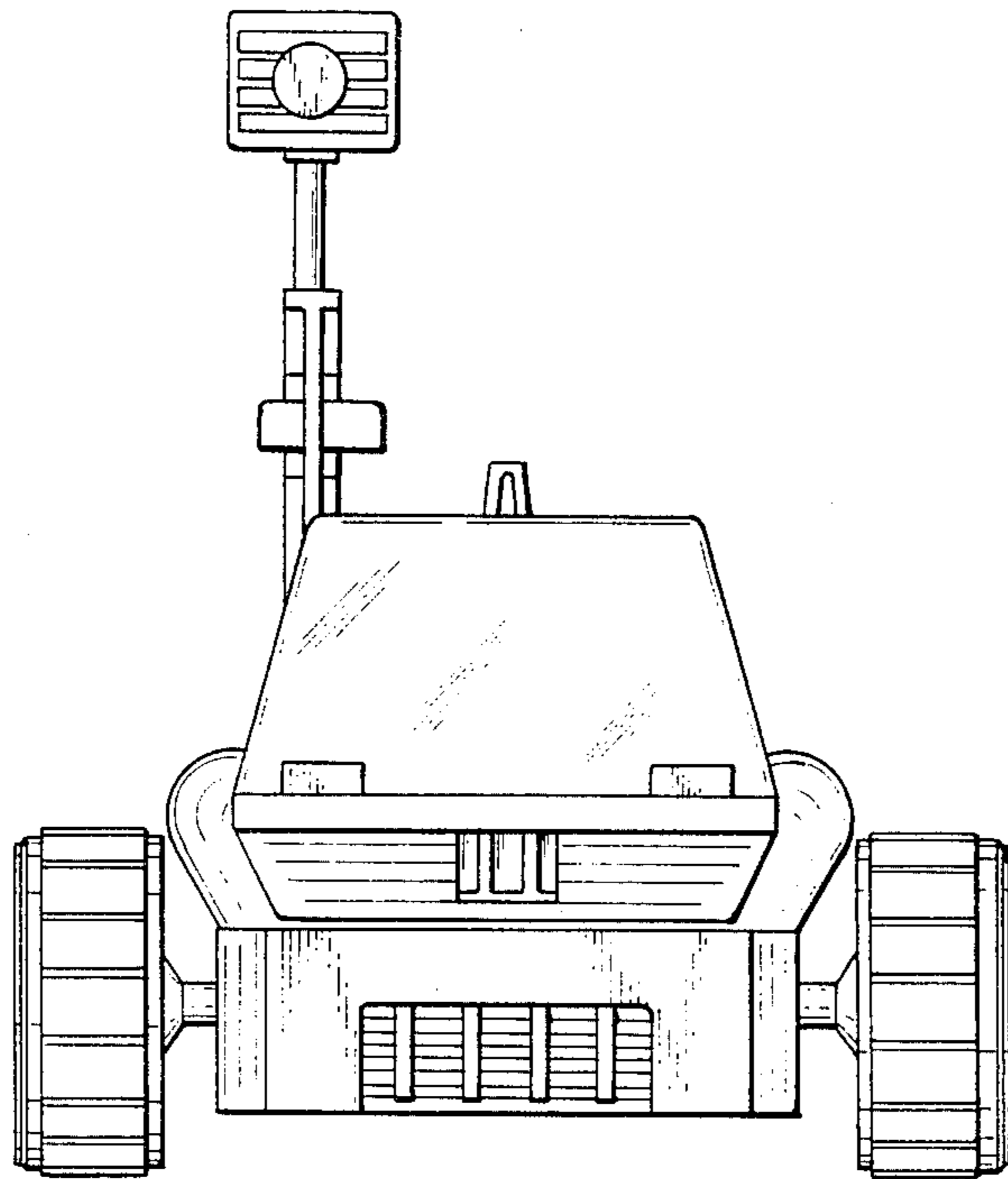

FIG. 1

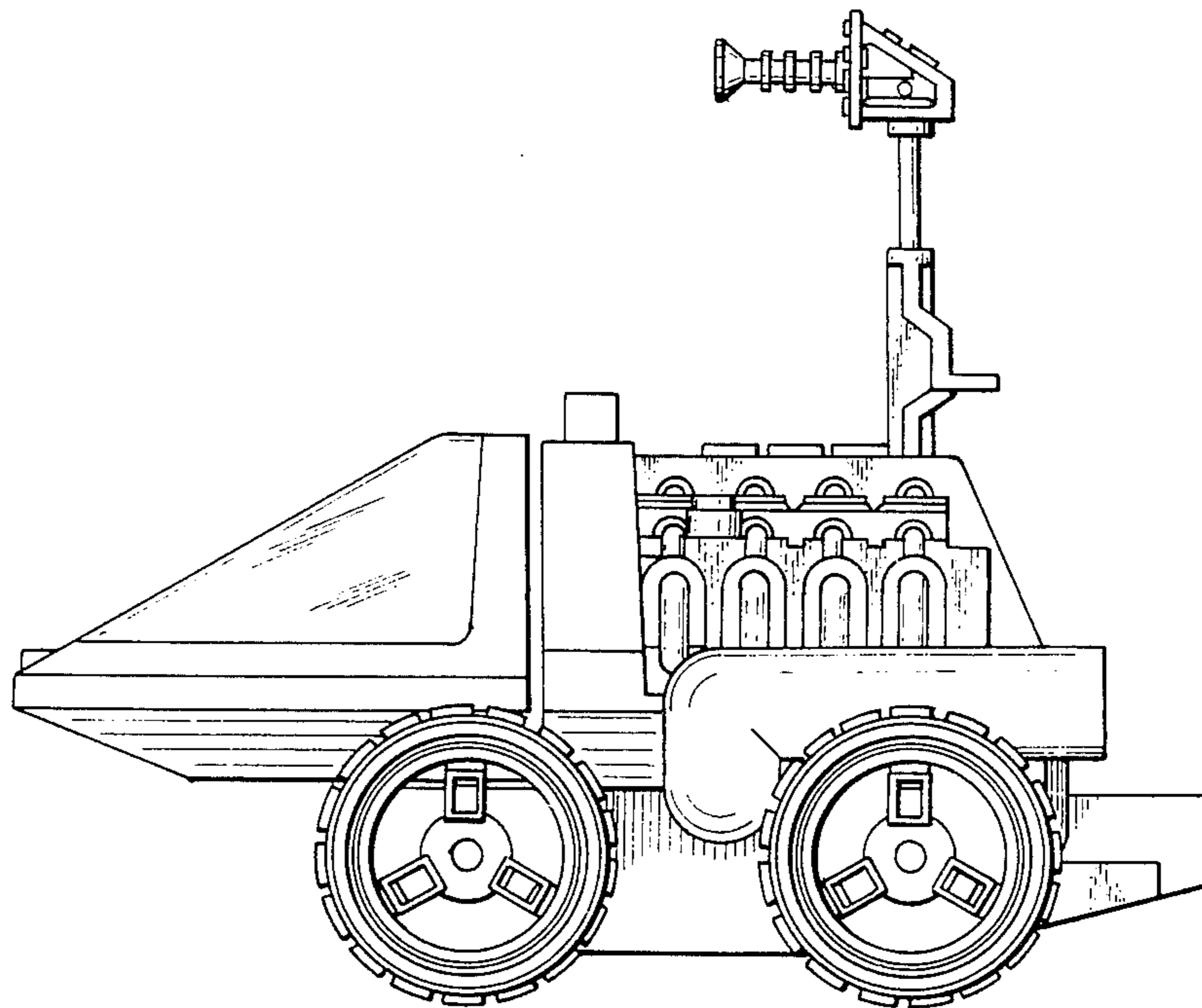

FIG. 2

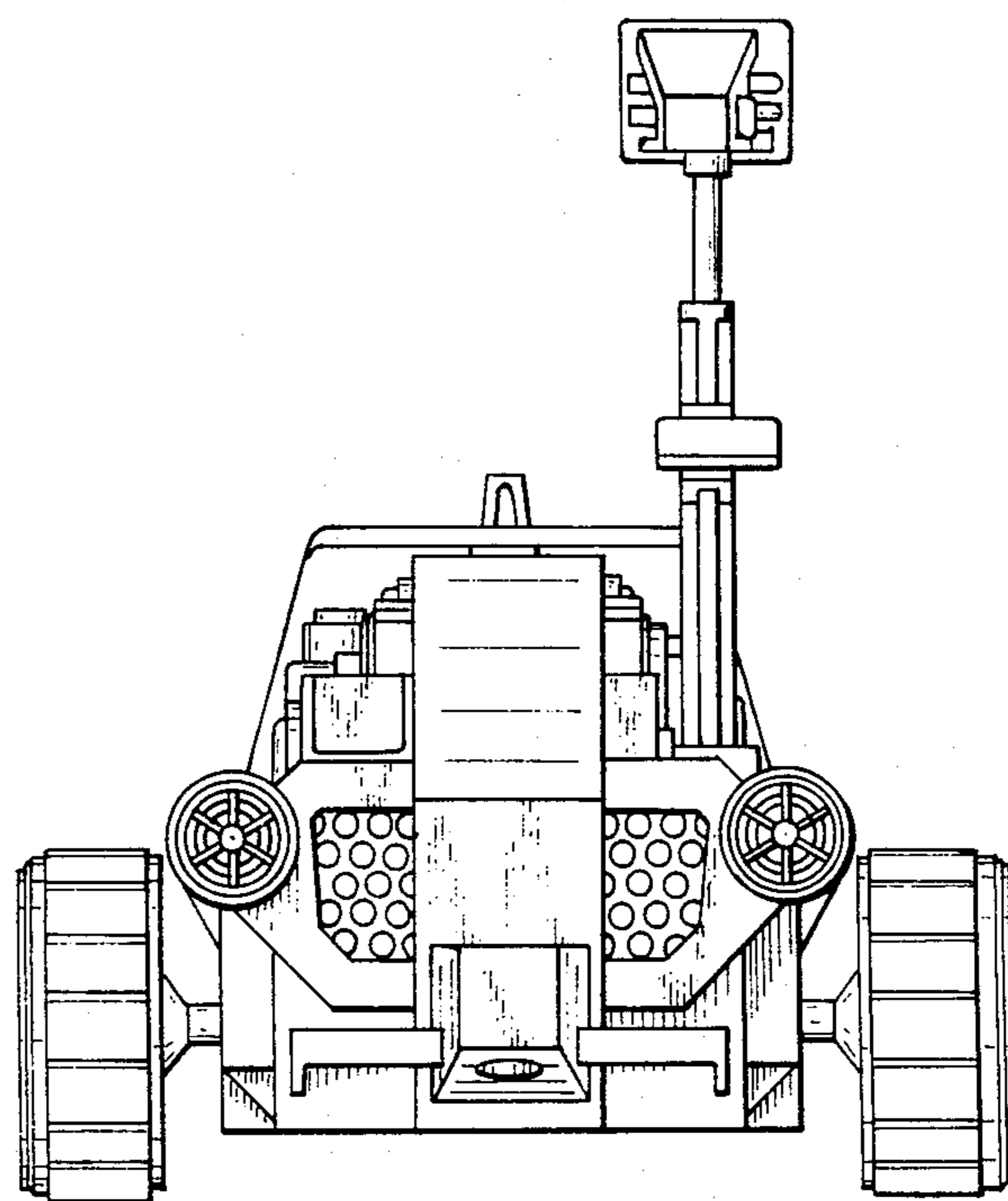

FIG. 3

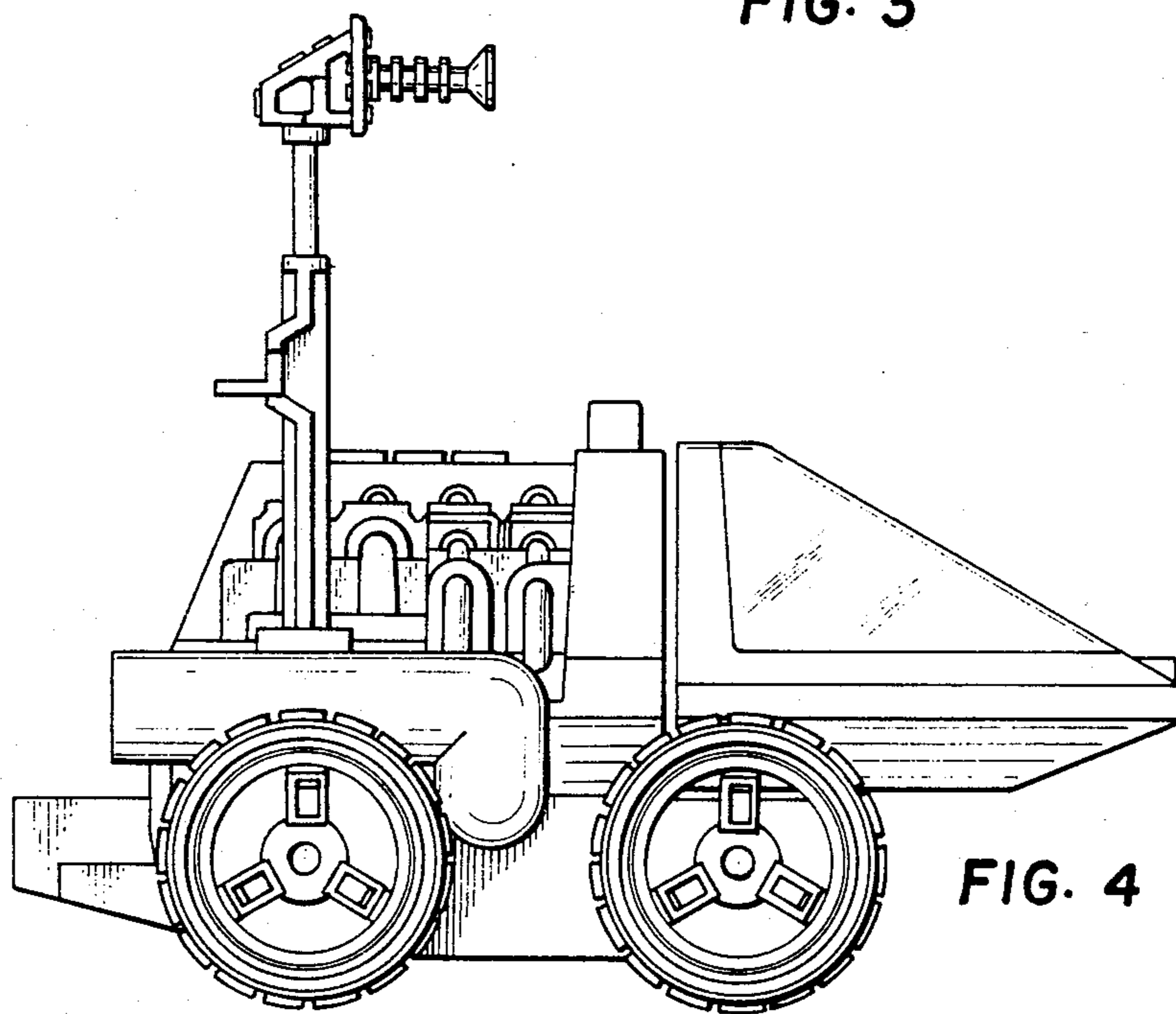

FIG. 4

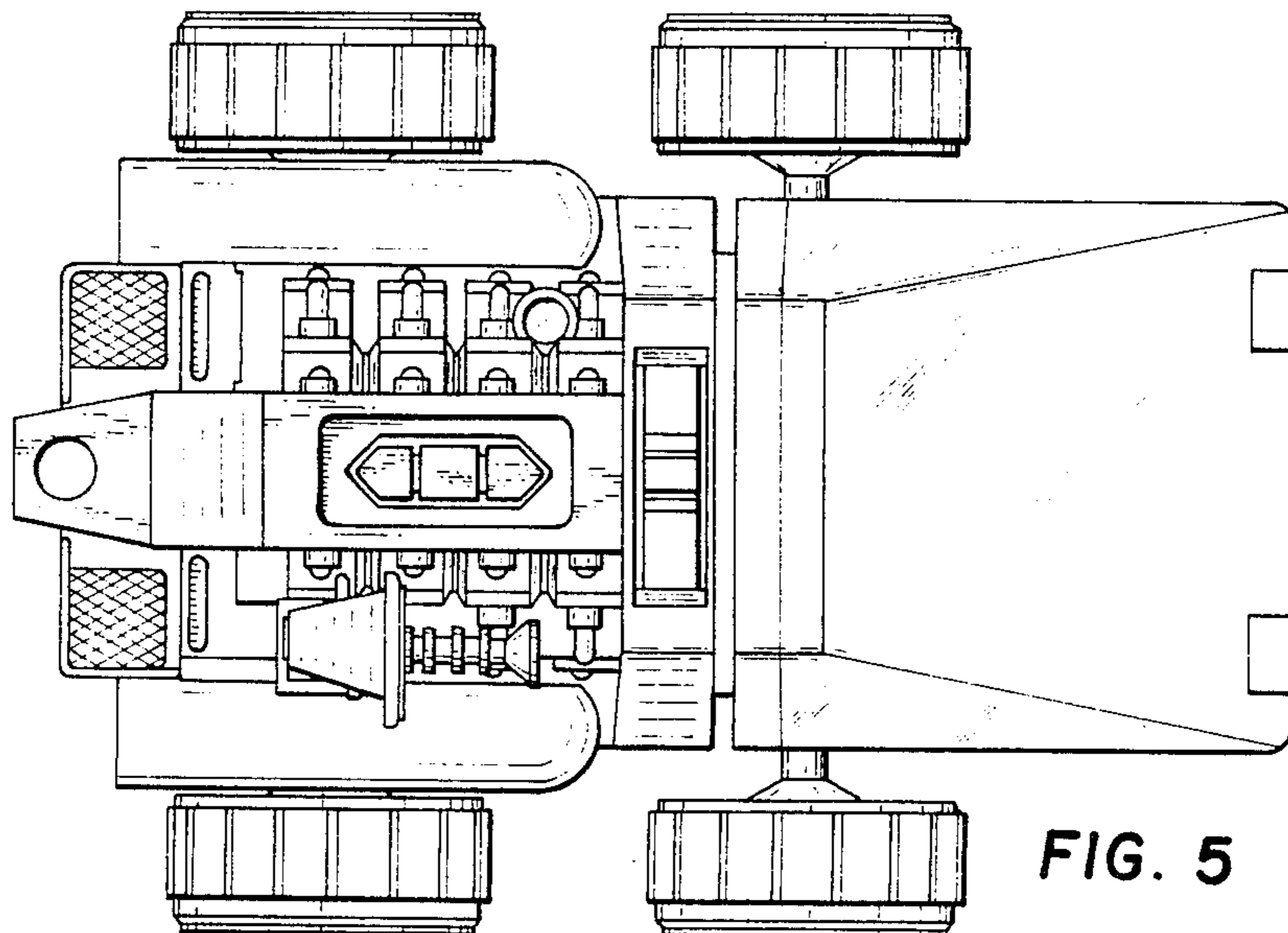

FIG. 5

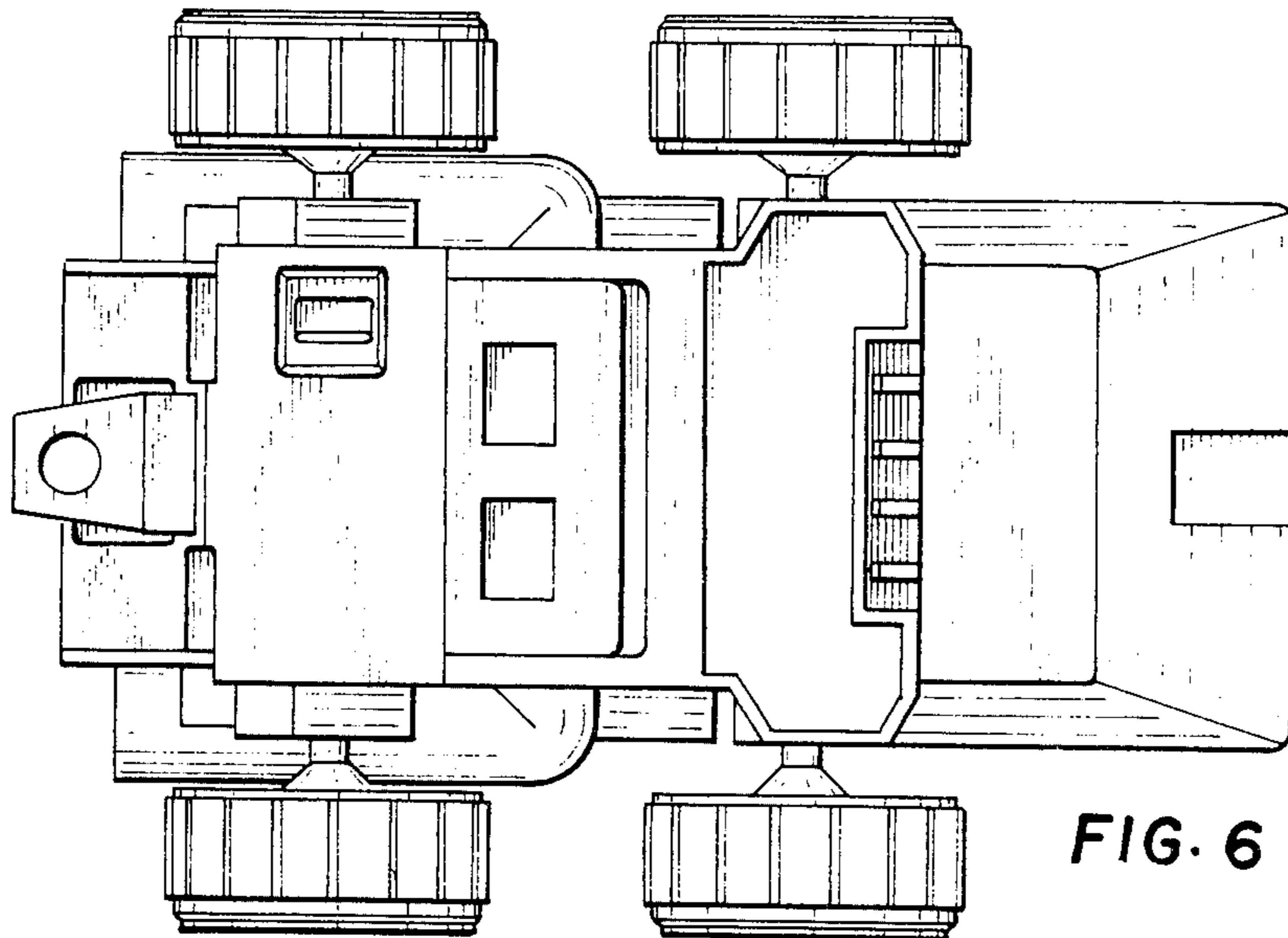

FIG. 6