

[54] **TOY AIRCRAFT**

[75] **Inventor: Steven W. Begg, Maidenhead, England**

[73] **Assignee: Anderson Burr Pictures Limited, London, England**

[**] **Term: 14 Years**

[21] **Appl. No.: 513,777**

[22] **Filed: Jul. 15, 1983**

[30] **Foreign Application Priority Data**

Jan. 24, 1983 [GB] United Kingdom 1010983
[52] **U.S. Cl. D21/87**
[58] **Field of Search D21/82, 87, 88, 89, D21/90, 124, 128; D12/319, 320, 321; 446/71, 72, 73, 34, 52, 56, 61, 66**

[56] **References Cited**

U.S. PATENT DOCUMENTS

D. 184,453	2/1959	Noble	D12/321
D. 202,149	8/1965	Burnelli	D21/87
D. 219,042	10/1970	King	D21/87
D. 240,438	7/1976	Rizzo	D21/87
D. 261,286	10/1981	Breneman	D21/87
D. 263,487	3/1982	LaCrone et al.	D21/87

Primary Examiner—Charles A. Rademaker
Attorney, Agent, or Firm—Dressler, Goldsmith, Shore, Sutker & Milnamow, Ltd.

[57] **CLAIM**

The ornamental design for a toy aircraft, substantially as shown.

DESCRIPTION

FIG. 1 is a side elevational view of a toy aircraft showing my new design;
FIG. 2 is a top plan view thereof;
FIG. 3 is a front elevational view thereof;
FIG. 4 is a rear elevational view thereof; and,
FIG. 5 is a bottom plan view thereof.

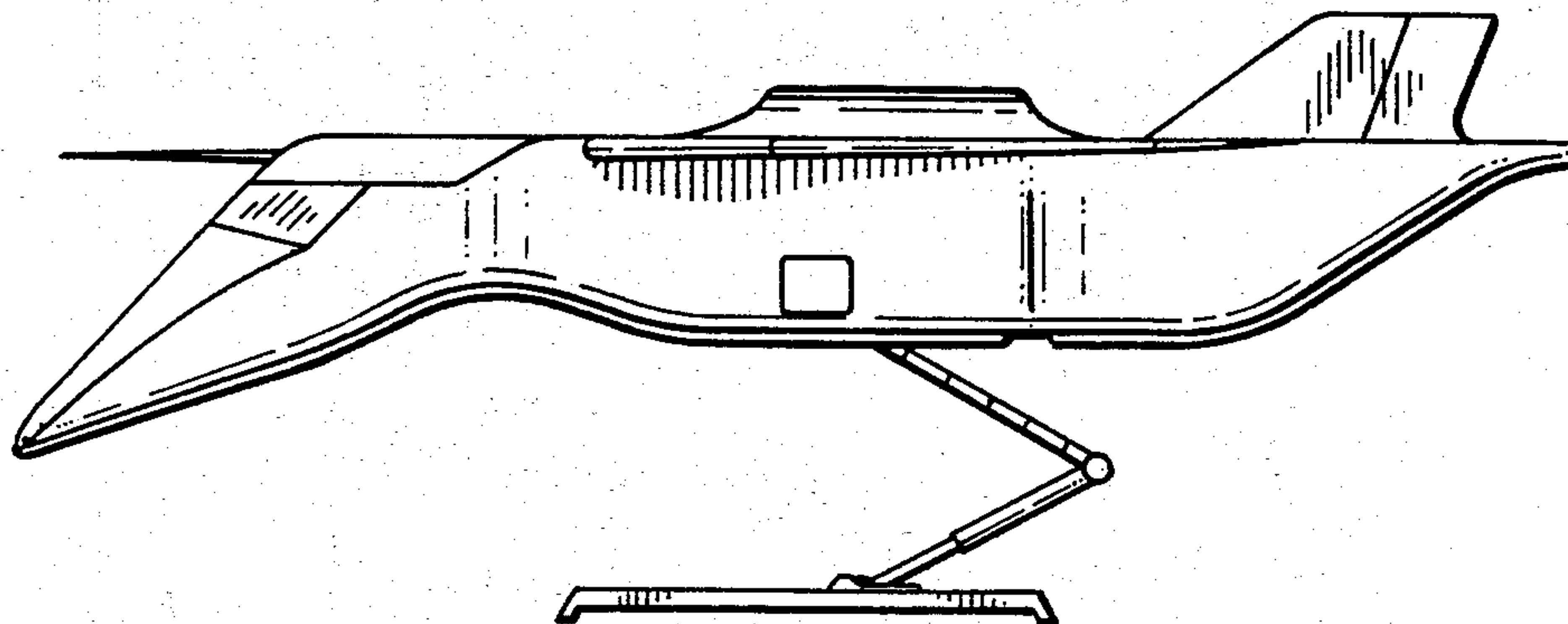

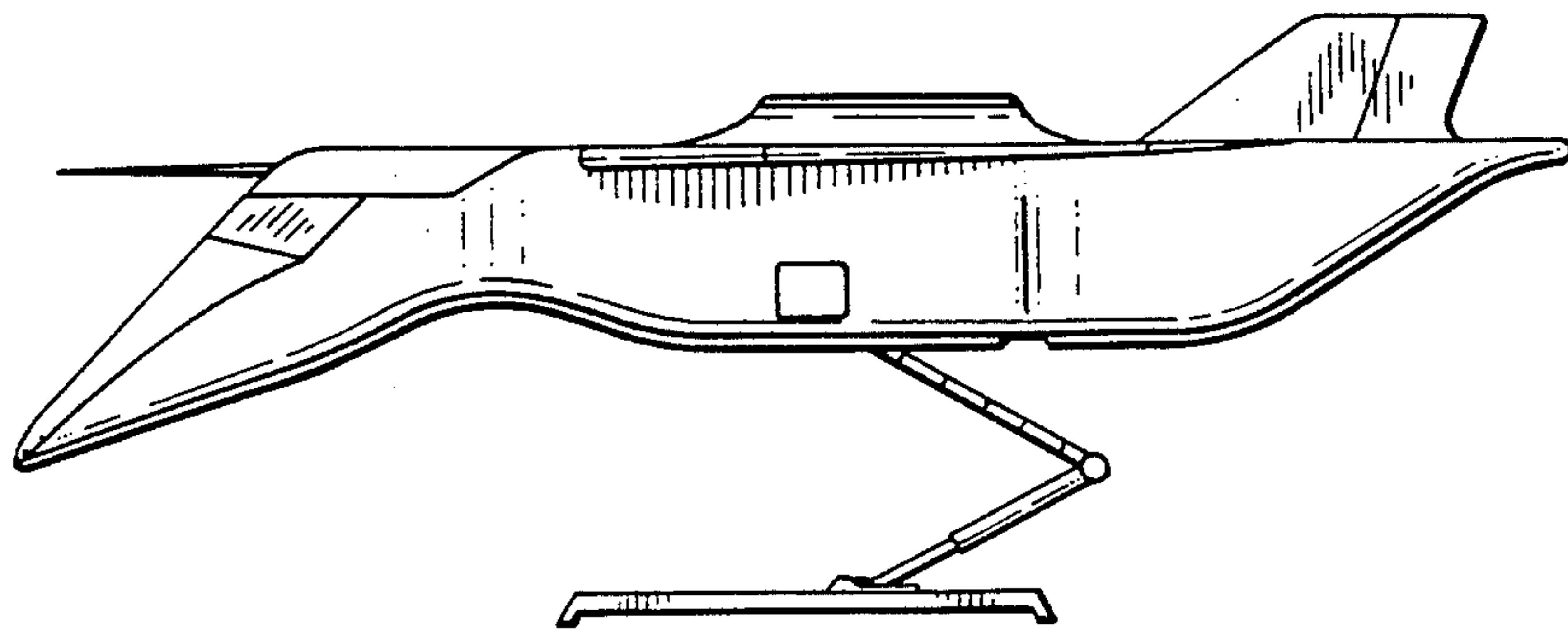

FIG. 1

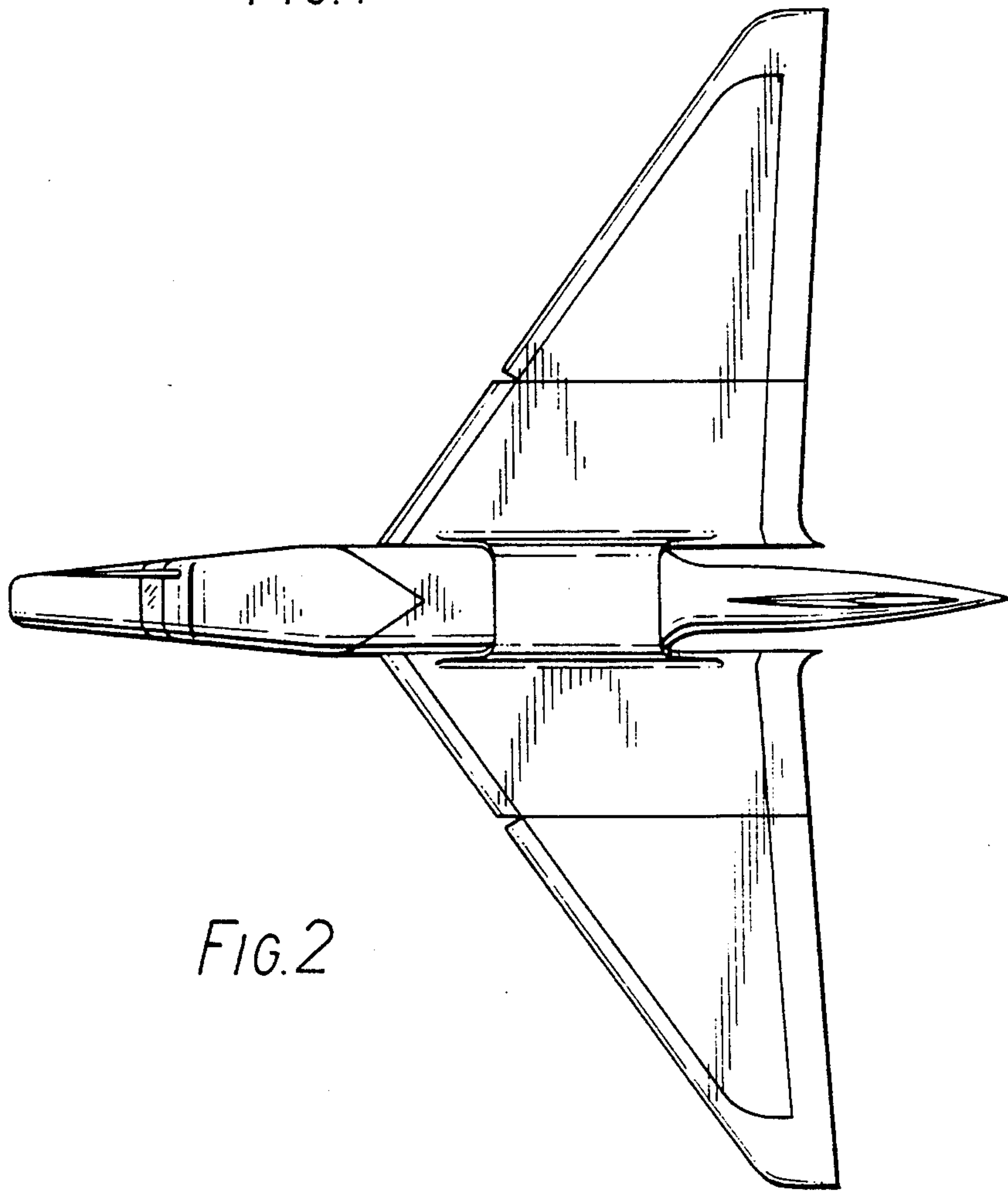

FIG. 2

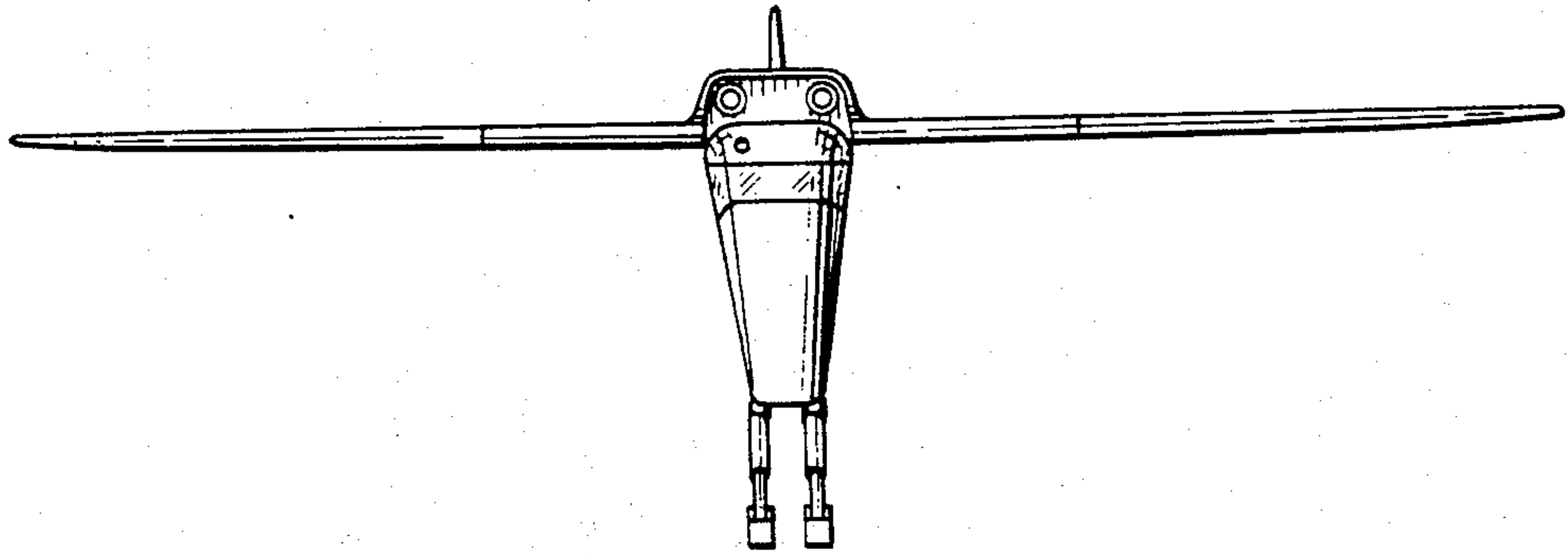

FIG. 3

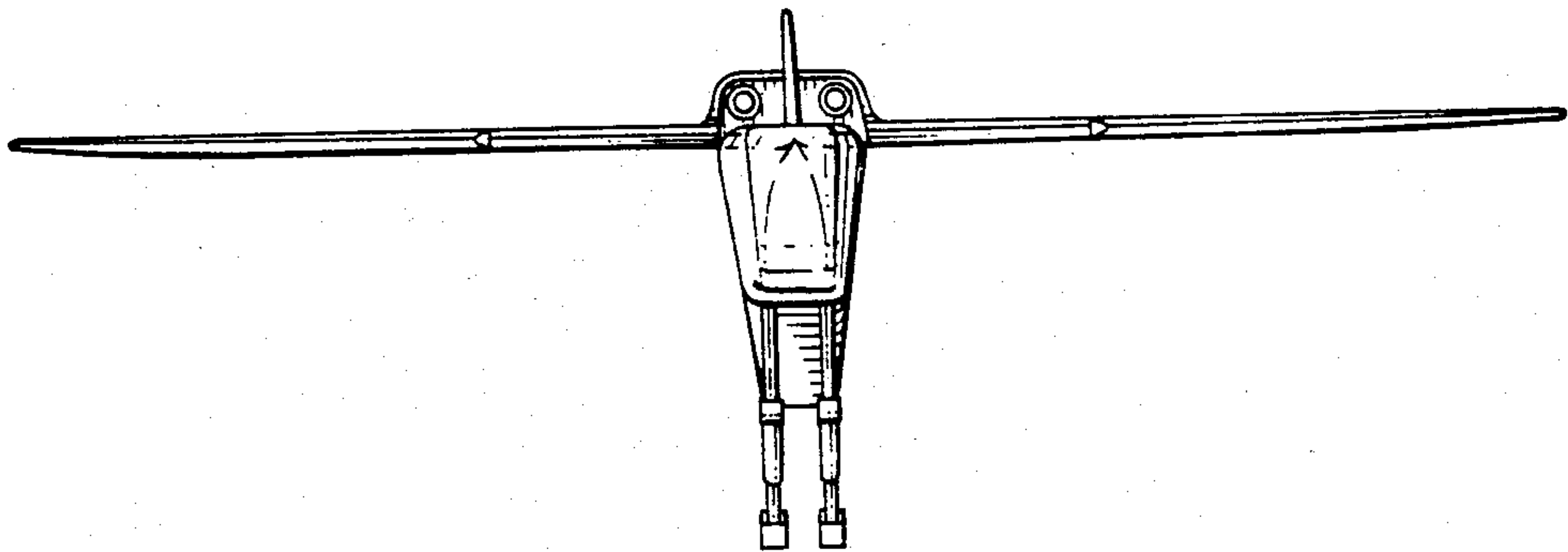

FIG. 4

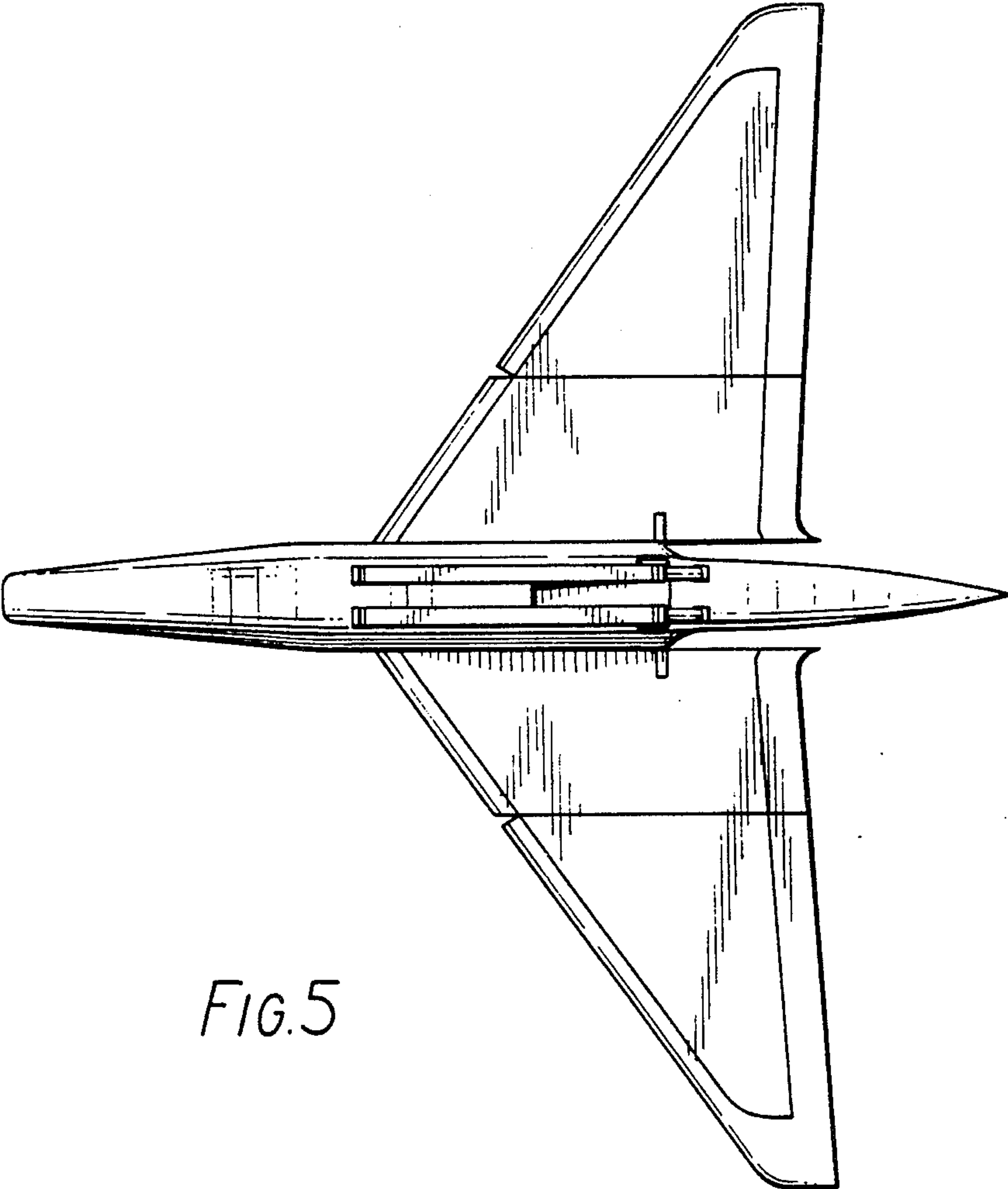

FIG. 5